

4"-16" Well Service Air Valve

Operation, Maintenance and Installation Manual

INTRODUCTION	1
RECEIVING AND STORAGE	1
DESCRIPTION OF OPERATION	1
VALVE CONSTRUCTION	2
INSTALLATION	3
OPTIONAL THROTTLING DEVICE ...	4
MAINTENANCE	4
TROUBLESHOOTING	4
DISASSEMBLY	5
RE-ASSEMBLY	5
PARTS AND SERVICE	5
WARRANTY	6



VAL-MATIC® VALVE AND MANUFACTURING CORP.

905 RIVERSIDE DR. ELMHURST, IL. 60126
TEL. 630/941-7600 FAX. 630/941-8042

VAL-MATIC'S 4"-16" WELL SERVICE AIR VALVE OPERATION, MAINTENANCE AND INSTALLATION

INTRODUCTION

The Well Service Air Valve has been designed with stainless steel trim to give years of trouble-free operation. This manual will provide you with the information to properly install and maintain the valve to ensure a long service life. The purpose of the valve is to automatically discharge and admit air into the discharge pipe of a well or vertical turbine pump.

This valve is not intended for fluids containing suspended solids such as wastewater. For wastewater and other high turbidity applications, use Val-Matic Series 300 Sewage Air/Vacuum Valves.

CAUTION: This valve is not intended for fluids containing suspended solids.
--

The valve is a float-operated, resilient-seated valve designed to handle clean fluids. The Size, Maximum Working Pressure, and Series No. are stamped on the nameplate for reference.

RECEIVING AND STORAGE

Inspect valves upon receipt for damage in shipment. Unload all valves carefully to the ground without dropping.

Valves should remain crated, clean and dry until installed to prevent weather related damage. For long term storage greater than six months, the rubber surfaces of the seat should be coated with a thin film of FDA approved grease such as Lubriko #CW-606. Do not expose seat to sunlight or ozone for any extended period.

DESCRIPTION OF OPERATION

The Well Service Air Valve is designed to exhaust large quantities of air upon pump start-up and allow air to re-enter the line upon pump shut-down. Flanged valves are equipped with an anti-slam device which throttles the flow of water into the upper chamber after the air has been exhausted.

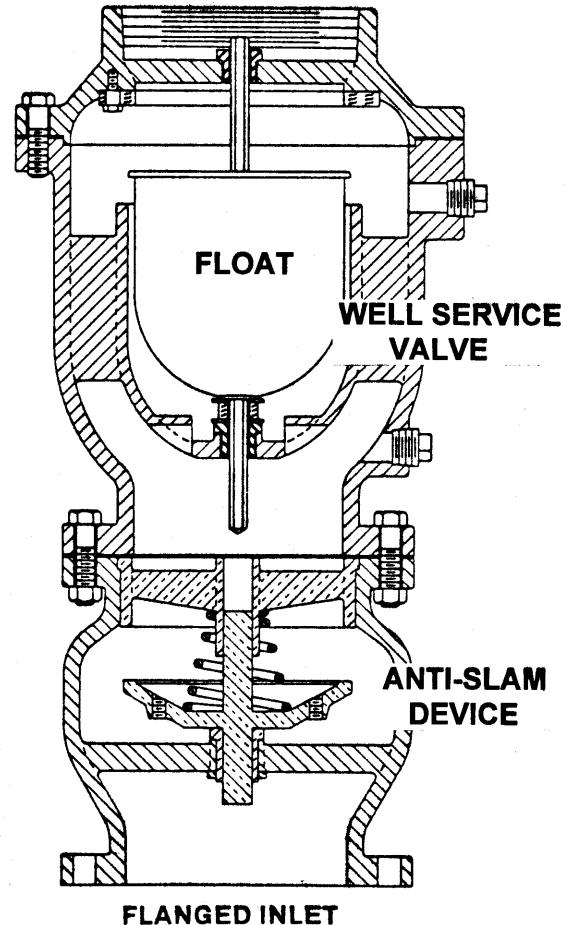

FIGURE 1. 4"-16" WELL SERVICE AIR VALVE

The anti-slam device causes the valve to fill at a slower rate and thereby prevents a rapid closure of the valve. As water enters the valve during start-up, the float will rise, closing the outlet port. The valve will remain closed while the pump is running. After pump shutdown, the valve opens to allow air to re-enter the pipe to prevent a vacuum condition from forming in the pump discharge line. The only moving part in the valve is the float which is equipped with guides. This assures that the float makes contact with the resilient seat at the optimum angle thus assuring long maintenance free life.

VALVE CONSTRUCTION

The Well Service Air Valve is constructed of rugged cast iron. All internal components are stainless steel with the exception of the valve seat which is resilient. See the specific Material List submitted for the order if other than standard construction. The float (5) is the only moving part assuring long life with minimal maintenance. The general details of construction are illustrated in Figure 2. The body (1) is flanged for connection to the anti-slam device. The seat (4) is retained in the cast cover (2) by fasteners (8).

ITEM	DESCRIPTION	MATERIAL
1	Body	Cast Iron
2	Cover	Cast Iron
4	Seat*	Buna-N
5	Float*	Stainless Steel
6	Gasket*	Non-Asbestos
7	Cover Bolt	Alloy Steel
8	Retaining Screw*	Stainless Steel
9	Guide Bushing*	Stainless Steel
15	Cushion*	Buna-N
26	Seat Screw Sleeves*	Stainless Steel
28	Pipe Plug	Malleable Iron
	*RECOMMENDED SPARE PART	

TABLE 1. WELL SERVICE VALVE PARTS LIST

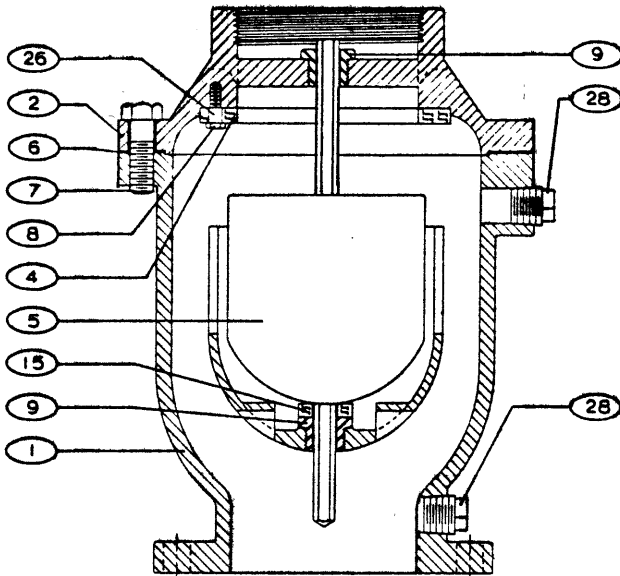

FIGURE 2. 4"-16" WELL SERVICE AIR VALVE

Anti-Slam Device Construction: The standard body is cast iron with a bronze or stainless steel disc. See specific Materials List submitted for the order if other than standard cast iron construction. The general details of construction are illustrated in Figure 3. The body (1) is flanged for connection to the pipeline. The disc (3) is held open by a spring (4) until water rapidly enters the device. Flow continues through the orifices in the disc to operate the well service valve.

ITEM	DESCRIPTION	MATERIAL
1	Body	Cast Iron
2	Seat	Bronze
3	Disc	Bronze
4	Spring	Stainless Steel
5	Bushing	Brass
6	Seat Ret. Screw	Stainless Steel
7	Retainer Nut	Brass
	*RECOMMENDED SPARE PART	

TABLE 2. ANTI-SLAM VALVE PARTS LIST

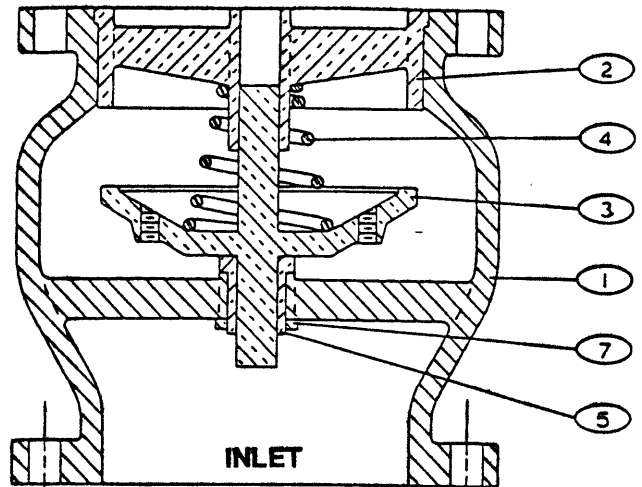

FIGURE 3. ANTI-SLAM DEVICE

INSTALLATION

The installation of the valve is important for its proper operation, see Figure 4. Valves must be installed in the vertical position with the inlet down on the discharge pipe between the pump and the check valve. For In-plant installations, vent piping is installed on the discharge of the valve to direct the discharge air and fluid from the valve to a safe location or open drain.

A shut off valve is optional but useful for servicing the valve. The optional throttling device is installed on the discharge of the valve when needed to control the exhaust rate of the valve.

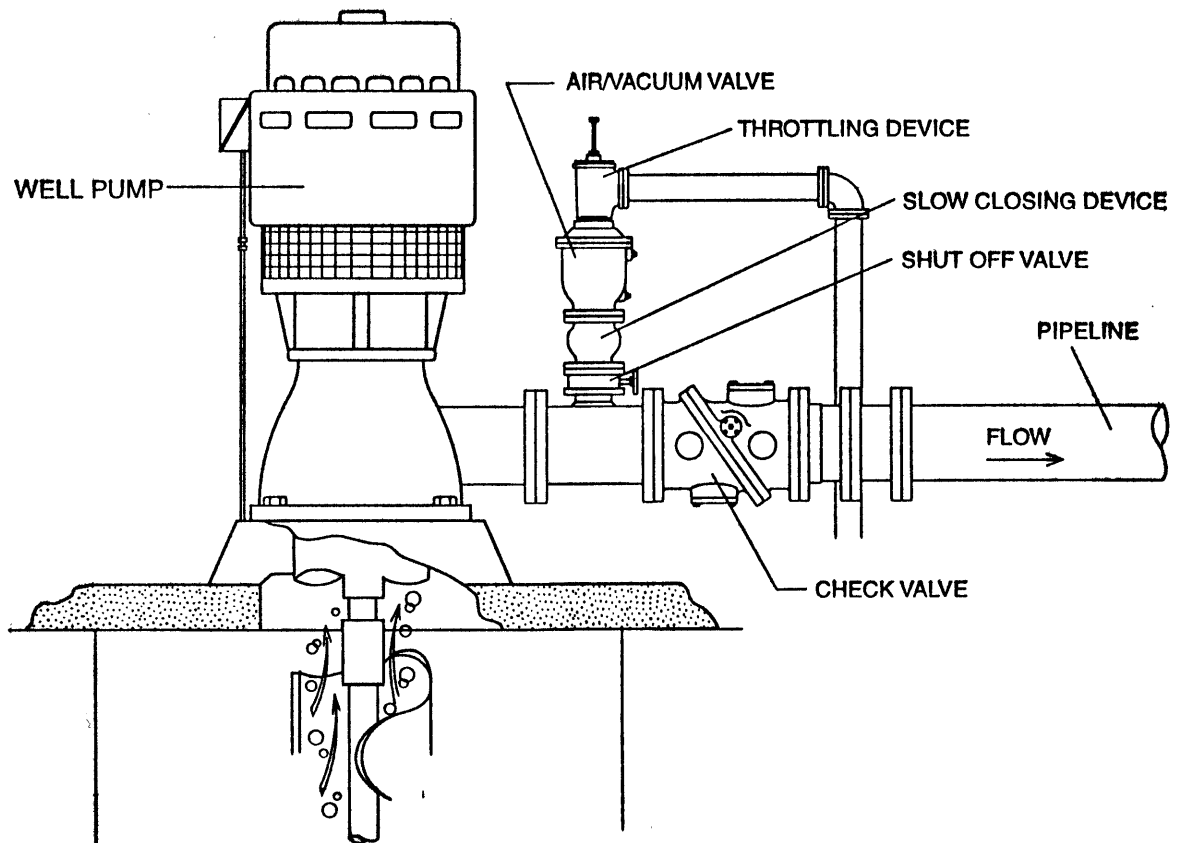

FIGURE 4. TYPICAL WELL SERVICE AIR VALVE INSTALLATION

OPTIONAL THROTTLING DEVICE

The valve may be equipped with an optional throttling device as shown in Figure 5. The throttling device is installed on top of the Well Service Air Valve and controls the rate at which air is exhausted from the pipe during pump start-up.

Set the throttling device in the mid-position. If there is a sudden pressure spike in the pump discharge line during pump start-up, then throttle the device closed until the pressure surge is reduced. If air is driven through the main check valve during pump start-up, then open the throttling device further to allow a faster rate of air discharge. A lock nut is provided to lock the final setting.

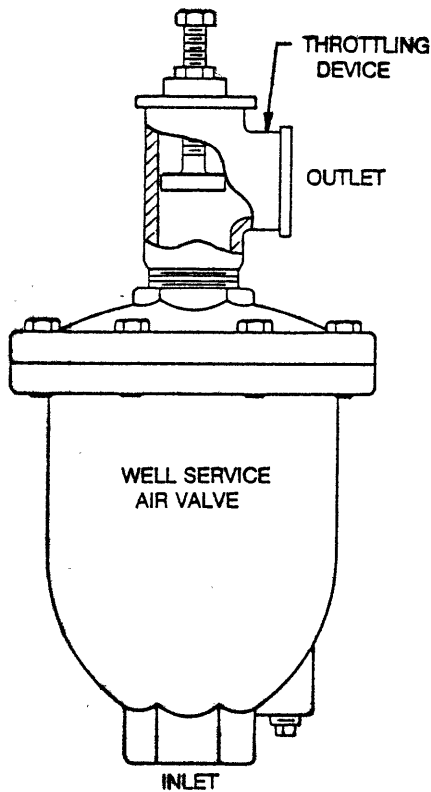

FIGURE 5. THROTTLING DEVICE

MAINTENANCE

The Well Service Air Valve requires no scheduled lubrication or maintenance.

INSPECTION: Annual inspection for leakage can be performed. Observe leakage from the air valve discharge pipe just after the pump has started to see if there is leakage of water. An initial burst or spray of water from the valve when it closes is common but the valve should then provide tight shutoff while the pump is running. If leakage occurs, the valve should be removed and inspected for wear or possible damage from foreign matter.

TROUBLESHOOTING

Several problems and solutions are presented below to assist you in troubleshooting the valve assembly in an efficient manner.

- **Leakage at Bottom Connection:** Tighten valve flange connection (See torques listed in Table 3). If leak persists, remove valve and replace gasket.
- **Leakage at Cover:** Tighten bolts (see Table 3), replace gasket.
- **Valve Leaks when Closed:** Inspect seat for dirt or damage and replace. Exercise float.
- **Valve Slams Closed:** Air may be exhausting too rapidly. Throttle exhaust of valve. Partially close down throttling device (Figure 5) if included.
- **Air is not exhausted:** Inspect float for free travel, damage or water leakage. Check that exhaust piping is not clogged or isolation valve inadvertently closed. Open throttle valve (Figure 5) wide open if included. Valve may be too small for application. Identify pump flow rate and call factory to check sizing.

DISASSEMBLY

The valve can be disassembled without removing it from the pipeline. Or for convenience, the valve can be removed from the line. All work on the valve should be performed by a skilled mechanic with proper tools. Refer to Figure 2.

WARNING: The valve must be drained before removing the cover or pressure may be released causing bodily harm.

1. Close inlet shut-off valve. Open drain valve or remove drain plug (28). Remove discharge piping and cover bolts (7) on the top cover.
2. Pry cover (2) loose and lift off valve body.
3. Remove retainer bolts (8) and inspect seat for cracks in rubber or wear in sealing surface.
4. Lift float (5) from body. Turn guide bushing (9) to remove it from body (1).
5. Unbolt well service valve and remove from top of anti-slam device (Figure 3). Replace gasket if damaged.
6. Remove small seat fasteners on flange face.
7. Lift seat, disc, and spring from body (Figure 3).
8. Bushing (5) can be unthreaded from body if worn.
9. Clean and inspect parts. Replace worn parts as necessary and lubricate parts with FDA approved grease such as Lubriko #CW-606. Remove all foreign material from body and cover.

RE-ASSEMBLY

All parts must be cleaned and gasket surfaces should be cleaned with a stiff wire brush in the direction of the serrations or machine marks. Worn parts, gaskets and seals should be replaced during reassembly.

1. Apply Loctite 242 to anti-slam device bushing (5, Figure 3) and screw into body (1).
2. Place disc, spring, and seat (2) in the body and retain with round head seat fasteners (6).

3. Place gasket over flange. The gasket must cover the seat (2) for proper seat retention.
4. Place Well Service Valve body (Figure 2) on the anti-slam device flange and install flange bolts and nuts per Table 3.
5. Apply Loctite 242 to guide bushing threads (9) and thread bushing into valve body (1).
6. Lay seat (4) over inverted cover (2) with the flat surface against toward the cover. Fasten seat with screws (8) and sleeves (26). Tighten fasteners to 5 ft-lbs. Do not use excessive torque.
7. Install float (5) through body bushing (9).
8. Lay cover gasket (6) over bolt holes in body and secure cover with lubricated bolts (7). Using a cross over tightening method, tighten to the torques listed in Table 3 in three increments
9. Place valve back in service. Slowly open the inlet isolation valve. Check flanges for leakage.

<u>BOLT SIZE</u>	<u>TORQUE (FT-LBS)</u>
1/2"	45
5/8"	93
3/4"	150
7/8"	202
1"	300
1-1/8"	450
1-1/4"	650
1-3/8"	800

TABLE 3. COVER AND FLANGE BOLT TORQUES

PARTS AND SERVICE

Parts and service are available from your local representative or the factory. Make note of the valve Size, Series No, and Serial No. located on the valve nameplate and contact:

Val-Matic Valve and Mfg. Corp.
905 Riverside Drive
Elmhurst, IL 60126
PH: 630/941-7600
FAX: 630/941-8042

A sales representative will quote prices for parts or arrange for service as needed.

LIMITED WARRANTY

All products are warranted to be free of defects in material and workmanship for a period of one year from the date of shipment, subject to the limitations below.

If the purchaser believes a product is defective, the purchaser shall: (a) Notify the manufacturer, state the alleged defect and request permission to return the product; (b) if permission is given, return the product with transportation prepaid. If the product is accepted for return and found to be defective, the manufacturer will, at his discretion, either repair or replace the product, f.o.b. factory, within 60 days of receipt, or refund the purchase price. Other than to repair, replace or refund as described above, purchaser agrees that manufacturer shall not be liable for any loss, costs, expenses or damages of any kind arising out of the product, its use, installation or replacement, labeling, instructions, information or technical data of any kind, description of product use, sample or model, warnings or lack of any of the foregoing. NO OTHER WARRANTIES, WRITTEN OR ORAL, EXPRESS OR IMPLIED, INCLUDING THE WARRANTIES OF FITNESS FOR A PARTICULAR PURPOSE AND MERCHANTABILITY, ARE MADE OR AUTHORIZED. NO AFFIRMATION OF FACT, PROMISE, DESCRIPTION OF PRODUCT OF USE OR SAMPLE OR MODEL SHALL CREATE ANY WARRANTY FROM MANUFACTURER, UNLESS SIGNED BY THE PRESIDENT OF THE MANUFACTURER. These products are not manufactured, sold or intended for personal, family or household purposes.

VAL-MATIC[®]

VAL-MATIC[®] VALVE AND MANUFACTURING CORP.

905 RIVERSIDE DR. ELMHURST, IL. 60126
TEL. 630/941-7600 FAX. 630/941-8042