

# Threaded Silent Check Valve

## Operation, Maintenance and Installation Manual

INTRODUCTION .....	1
RECEIVING AND STORAGE .....	1
DESCRIPTION OF OPERATION .....	1
INSTALLATION .....	1
VALVE CONSTRUCTION .....	2
MAINTENANCE.....	2
TROUBLESHOOTING.....	2
DISASSEMBLY.....	3
REASSEMBLY.....	3
PARTS AND SERVICE.....	3
WARRANTY .....	4



VAL-MATIC® VALVE AND MANUFACTURING CORP.

905 Riverside Dr. • Elmhurst, IL 60126  
Phone (630) 941-7600 • Fax (630) 941-8042  
[www.valmatic.com](http://www.valmatic.com)

# THREADED STYLE SILENT CHECK VALVE OPERATION, MAINTENANCE AND INSTALLATION

## INTRODUCTION

This manual will provide you with the information to properly install and maintain the valve to ensure a long service life. The Threaded Silent Check Valve is ruggedly constructed of lead-free bronze to give years of trouble free operation. The valve should be installed in horizontal or vertical pipes carrying clean water.

The Threaded Silent Check Valve is designed to open fully to provide flow in the forward direction and close rapidly upon flow reversal. The valves are used to prevent reverse flow through pumps or in piping systems. The size and cold working pressure (250 CWP) are marked on the body for reference.

This valve is not intended for fluids containing suspended solids such as wastewater.

### **CAUTION**

**This valve is not intended for fluids containing suspended solids or hazardous fluids.**

## RECEIVING AND STORAGE

Inspect valves upon receipt for damage in shipment. The valves should remain boxed, clean and dry until installed to prevent weather related damage. For long term storage, no special provisions are needed.

## DESCRIPTION OF OPERATION

The Threaded Silent Check Valve is designed to prevent reverse flow automatically. On pump start-up, the flow of water enters the valve from the seat end (right side in Figure 1) and forces the disc open, allowing the passage of fluid through the valve.

On pump shut-down, the spring closes the disc rapidly before a flow reversal takes place. This type of closure, which prevents flow reversal, is the factor which provides "silent" operation and reduces water hammer associated with check valve slam.

The valve body is supplied with NPT tapered threads on each end for installation in pipelines.

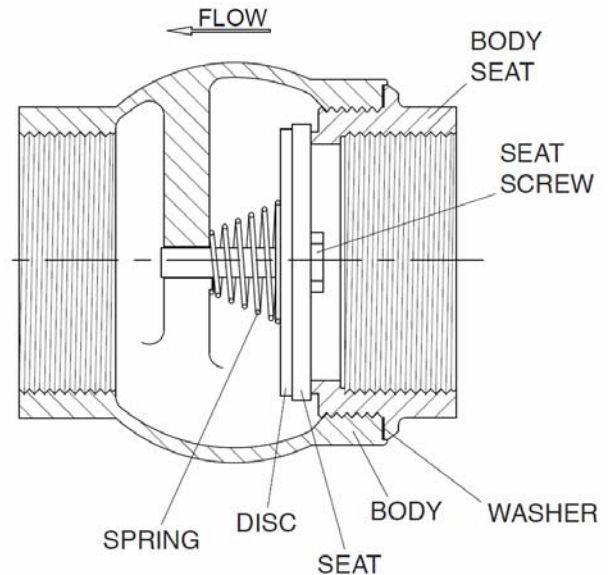

FIGURE 1. THREADED SILENT CHECK VALVE

## INSTALLATION

The installation of the valve is important for its proper operation. The **flow arrow** on the valve body must point in the direction of flow when the system is in operation. The valve can be installed in horizontal or vertical lines with the flow up or down.

Three diameters of straight pipe upstream of the valve are recommended to prevent turbulent flow streams through the valve, which can cause vibration and wear.

When installed in horizontal lines, the check valve does not have a specific upward orientation. Insert pipe nipples with thread sealant or thread tape and tighten while securing valve with a wrench on the body end nearest the pipe nipple.

### **CAUTION**

**The use of excessive torque can damage the valve.**

## VALVE CONSTRUCTION

The standard threaded check valve body (1) is constructed of lead-free bronze and is certified to comply with NSF/ANSI 372, "Drinking Water System Components – Lead Content." The internal metal components are bronze or stainless steel. The body (1) is threaded and designed to accept pipe nipples with NPT pipe threads. The disc (3) and spring (4) are the only moving parts and require no maintenance or lubrication. The general details of construction are illustrated in Figure 2.

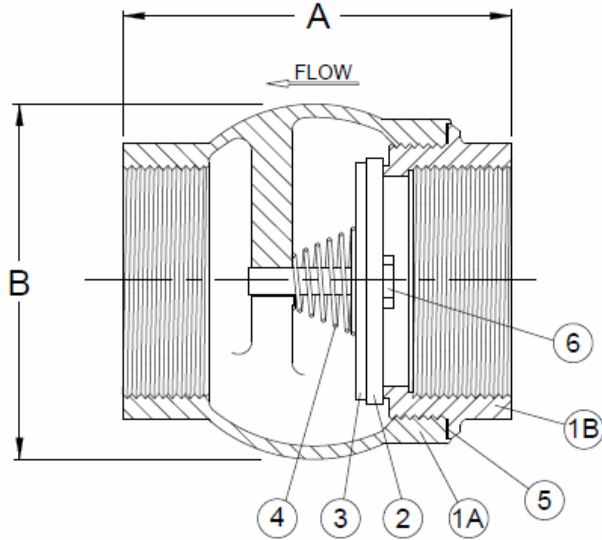

SEE DRAWING NO. VM-1400THR, 1-M FOR STANDARD MATERIALS OF CONSTRUCTION.  
VALVE DEPICTS 2 INCH SIZE TO SCALE.

VALVE SIZE	MODEL NO.	A	B
1/2" NPT	1400.5THR.1	2.06	1.38
3/4" NPT	1400.75THR.1	2.25	1.63
1" NPT	1401THR.1	2.63	2.00
1 1/4" NPT	1401.25THR.1	2.94	2.38
1 1/2" NPT	1401.5THR.1	3.31	2.75
2" NPT	1402THR.1	3.68	3.38

COLD WORKING PRESSURE 250 PSI

FIGURE 2. VALVE CONSTRUCTION

ITEM	DESCRIPTION	MATERIAL
1	Body	Lead Free Bronze
2	Seat	Teflon
3	Disc	Lead Free Bronze
4	Spring	Stainless Steel
6	Seat Screw	Lead Free Bronze

Spare Parts are not available for this valve.  
A replacement valve is recommended.

TABLE 1. CHECK VALVE PARTS LIST

## MAINTENANCE

Threaded Silent Check Valves require no scheduled lubrication or maintenance.

**INSPECTION:** Periodic inspection for leakage can be performed by listening for leakage noise from the valve while the pump is shut down. If leakage is heard, drain the pipeline, remove the valve, and inspect the seating surfaces for wear or mineral deposits. Clean or replace the valve as needed.

## TROUBLESHOOTING

Several problems and solutions are presented below to assist you in troubleshooting the valve assembly in an efficient manner.

- **Valve Chatters or Vibrates:** Verify that velocity is at least 4 feet per second. Noise sounding like rocks in the line can be cavitation due to high velocities, low downstream pressure, or an upstream expanded. Verify that there are three diameters of straight pipe upstream.
- **Valve Leakage:** Drain line, remove valve, and inspect seating surfaces for debris or damage. If body washer is leaking, apply torque to the two body pieces.
- **Valve Does Not Pass Flow:** Check flow arrow direction on valve body. Verify that downstream isolation valve is open and there is no line blockage downstream.
- **Valve Slams:** Remove valve and inspect spring.

## DISASSEMBLY

The valve should be removed from the pipeline for disassembly. A skilled mechanic with proper tools should perform all work on the valve. Refer to Figure 2.

### **WARNING**

**The line must be drained before removing the valve or pressure may be released causing injury.**

1. Clamp the downstream end of the valve body (1) lightly in a vise using the hex connection on the valve body. Do not over-clamp the valve or permanent distortion and leakage may occur. Remove the seat end of the valve using a wrench on the hex ends and unthread the body seat in a counterclockwise direction.
2. Lift up the disc assembly (3) from the body.
3. Examine the Teflon seat (2) and inspect the mating body seating surface for damage. Some minor dents and discoloration are normal. Grooves or wear areas will cause leakage and requires valve replacement.
4. Remove spring (4) and check for wear or cracks.

## REASSEMBLY

All parts must be clean and gasket surfaces should be cleaned with a stiff wire brush in the direction of the serrations or machine marks. Worn parts, gaskets, and seals should be replaced during reassembly.

1. Insert spring (5) into body (1).
2. Lay disc (3) over the spring.
3. Install the seat half of the body making sure that the body washer (5) is in place. Tighten the body pieces as a minimum to the torques shown in Table 2. If leakage is found during operation, elevate the torques until leakage stops.

Body Assembly Torque	
Valve Size	Torque
1/2"	50 ft-lbs
3/4"	75 ft-lbs
1"	100 ft-lbs
1-1/4"	125 ft-lbs
1-1/2"	150 ft-lbs
2"	200 ft-lbs

**TABLE 2. ASSEMBLY TORQUES**

## PARTS AND SERVICE

Parts and service are available from your local representative or the factory. Make note of the Valve Size and Model Number located on the valve nameplate and contact:

Val-Matic Valve and Manufacturing Corp.  
905 Riverside Drive  
Elmhurst, IL 60126  
Phone: (630) 941-7600  
Fax: (630) 941-8042  
[www.valmatic.com](http://www.valmatic.com)

A sales representative will quote prices for parts or arrange for service as needed.

### LIMITED WARRANTY

All products are warranted to be free of defects in material and workmanship for a period of one year from the date of shipment, subject to the limitations below.

If the purchaser believes a product is defective, the purchaser shall: (a) Notify the manufacturer, state the alleged defect and request permission to return the product; (b) if permission is given, return the product with transportation prepaid. If the product is accepted for return and found to be defective, the manufacturer will, at his discretion, either repair or replace the product, f.o.b. factory, within 60 days of receipt, or refund the purchase price. Other than to repair, replace or refund as described above, purchaser agrees that manufacturer shall not be liable for any loss, costs, expenses or damages of any kind arising out of the product, its use, installation or replacement, labeling, instructions, information or technical data of any kind, description of product use, sample or model, warnings or lack of any of the foregoing. NO OTHER WARRANTIES, WRITTEN OR ORAL, EXPRESS OR IMPLIED, INCLUDING THE WARRANTIES OF FITNESS FOR A PARTICULAR PURPOSE AND MERCHANTABILITY, ARE MADE OR AUTHORIZED. NO AFFIRMATION OF FACT, PROMISE, DESCRIPTION OF PRODUCT OF USE OR SAMPLE OR MODEL SHALL CREATE ANY WARRANTY FROM MANUFACTURER, UNLESS SIGNED BY THE PRESIDENT OF THE MANUFACTURER. These products are not manufactured, sold or intended for personal, family or household purposes.



**VAL-MATIC® VALVE AND MANUFACTURING CORP.**

905 Riverside Dr. • Elmhurst, IL 60126  
Phone (630) 941-7600 • Fax (630) 941-8042  
[www.valmatic.com](http://www.valmatic.com)