

Val-Matic® LS Cylinder Actuator

Operation, Maintenance and Installation Manual

INTRODUCTION	2
RECEIVING AND STORAGE.....	2
DESCRIPTION OF OPERATION	2
CONSTRUCTION.....	3
INSTALLATION REQUIREMENTS.....	3
MAINTENANCE	4
TROUBLESHOOTING	5
DISASSEMBLY	5
REASSEMBLY.....	5
PARTS & SERVICE	6
WARRANTY.....	6



VALVE AND MANUFACTURING CORP.

905 Riverside Dr. • Elmhurst, IL 60126
Phone (630) 941-7600 • Fax (630) 941-8042

VAL-MATIC'S LS CYLINDER ACTUATOR OPERATION, MAINTENANCE AND INSTALLATION

INTRODUCTION

The Series LS Cylinder Actuator has been designed to provide long trouble-free operation. This manual will provide you with the information to properly maintain the actuator to ensure a long service life. The actuator provides quarter-turn operation of valves using pneumatic, hydraulic or water-hydraulic power.

CAUTION: Do not use the actuator for supply pressures higher than nameplate rating or leakage and damage to equipment may occur.

RECEIVING AND STORAGE

Inspect valves and actuators upon receipt for damage in shipment. Unload all valves carefully to the ground without dropping. Do not lift valves with slings or chains around the actuator or through the seat area. Lift valve with straps or hooks in the flange holes. Extra care must be taken when handling cylinder actuators with controls and control piping.

Valves should remain crated, clean and dry until installed to prevent weather related damage. The valve is shipped slightly open to maintain the resilient seat in the un-loaded condition.

For long-term storage greater than six months, indoor storage is recommended.

DESCRIPTION OF OPERATION

As shown in Figure 1, the actuator consists of a housing and a tie-rod type cylinder. The actuator housing is rigidly bolted to the valve. The actuator lever drives the valve stem and key through 90 degrees of operation. The lever is driven by the cylinder, which in turn is powered by air, oil, or water pressure between 40 and 150 psig.

The cylinder is controlled by manual or electric directional valves and the speed can be regulated with flow control valves.

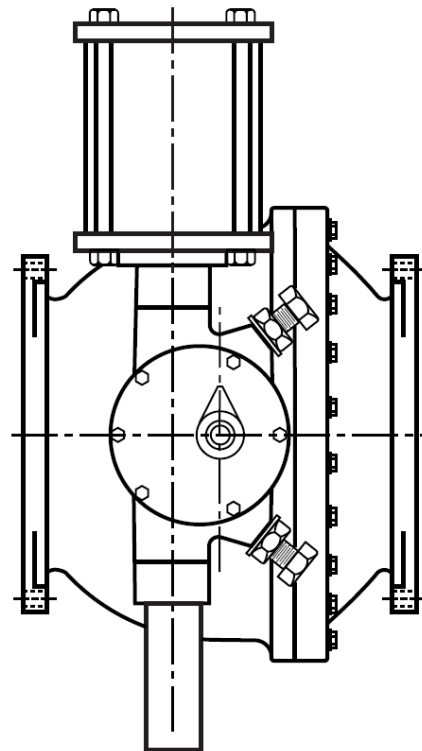

FIGURE 1. LS CYLINDER ACTUATOR

ACTUATOR CONSTRUCTION

The actuator consists of a tie-rod cylinder and a quarter-turn lever mechanism, see Figure 2.

The cylinder is powered by supply media (air oil or water). The pressure exerts a force on the piston (65), which in turn transmits the force through the cylinder rod (66) to the crosshead (12). The crosshead rides in the slot of the lever (4) driving the lever through 90 degrees of rotation.

CAUTION: The supply media must not exceed 150 psig or damage to the actuator may occur.

The open and closed stop positions of the valve are settable by adjusting the stop bolts (7) located on the side of the actuator housing (1).

INSTALLATION REQUIREMENTS

Cylinder actuators are rigidly mounted on the valve and secured to the valve shaft with a keyed connection. A dowel pin (18) is connected to the shaft and extends through the cover of the housing. The pin drives an arrow (19) to indicate valve position. The indicator is adjustable by loosening the setscrew in the indicator.

The supply media is typically connected to a solenoid valve and in turn piped to the cylinder port elbows (85). The supply media can be clean air, oil, or water in pressures up to 150 psig.

The actuator can be mounted in any orientation. The valve open and closed positions can be adjusted by turning the stop bolts (7) in the side of the housing.

LUBRICATION

The unit is factory lubricated with EP-2 grease on the moving parts of the lever (4) and crosshead (12).

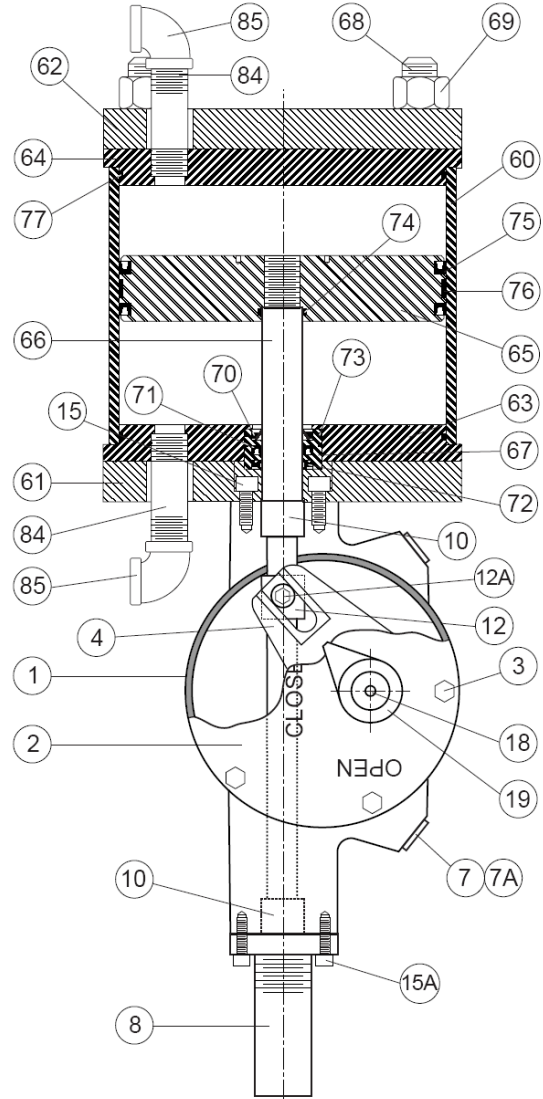
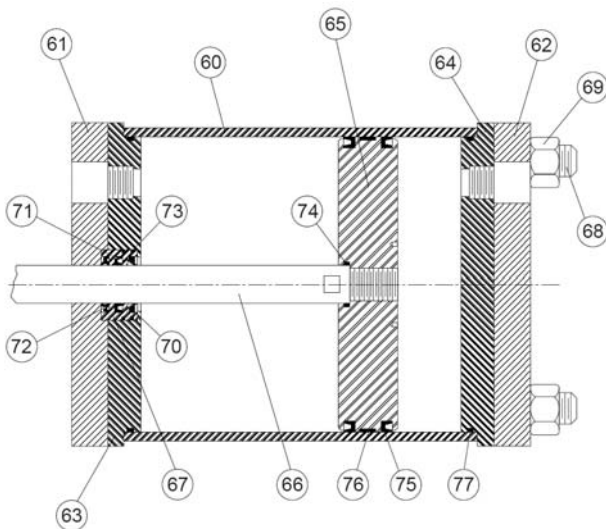

FIGURE 2. ACTUATOR CONSTRUCTION

ITEM	DESCRIPTION	MATERIAL
1	Housing	Iron
2	Housing Cover	Iron
3	Cover Bolts	Stainless Steel
4	Lever	Ductile Iron
7	Stop Bolt	Steel
7A	Lock Nut	Steel
8	End Cap	Steel
10	Rod Bearing	Teflon/Fiberglass
12	Crosshead	Bronze
12A	Crosshead Pin	Alloy Steel
15	Mounting Plate	Alloy Steel
15A	End Cap Bolt	Stainless Steel
18	Dowel Pin	Plated Steel
19	Indicator	Iron
60	Barrel	Stainless Steel
61	Mounting Plate	Steel
62	Support Plate	Steel
63	Head	Stainless Steel
64	Cap	Stainless Steel
65	Piston	Stainless Steel
66	Rod	Stainless Steel
67	Rod Gland*	Acetal Copolymer
68	Tie Rod	Alloy Steel, Plated
69	Nut	Alloy Steel, Plated
70	Rod Wiper*	Bronze/Nitrile
71	Rod Seal*	Nitrile
72	Rod Wiper*	Nitrile
73	Gland Seal*	Nitrile
74	Rod Seal*	Nitrile
75	Piston Seal*	Nitrile
76	Piston Wear Ring*	PTFE
77	Head Seal*	Nitrile
84	Pipe Nipple	Stainless Steel
85	Pipe Elbow	Stainless Steel

*Recommended Spare Part

FIGURE 3. ACTUATOR PARTS LIST



MAINTENANCE

The cylinder actuator requires no scheduled lubrication or maintenance.

ACTUATOR ADJUSTMENTS:

1) The valve open and closed positions can be adjusted by the stop bolts (7).

2) If leakage from the cylinder actuator occurs, tighten the pipe fittings or the tie rod nuts (69). If cylinder leakage continues, the head seals (77) may be damaged. Replace head and cap seal o-rings (77).

PISTON SEAL REPLACEMENT: If supply media flow continues while the piston is at the end of travel, the piston seals (75) may be worn. To replace the seals:

1. Remove the cylinder pressure and drain the cylinder.

WARNING: The cylinder supply must be removed and cylinder drained before working on the cylinder or bodily injury or damage to property may result.

2. Remove the tie rod nuts (69).
3. Pull the Support Plate (62), Cap (64), and barrel (60).
4. Use a spanner wrench to remove the piston (65) from the rod (66).
5. Remove the cylinder head (63) together with the rod gland assembly (67). Replace all seals as required.
6. Reassemble and tighten tie rod nuts to the torques shown below.

Size	Torque (ft-lbs)
1/4"	6
5/16"	11
3/8"	19
7/16"	30
1/2"	45
5/8"	93
3/4"	150
7/8"	202

TROUBLESHOOTING

Some problems and solutions are presented below to assist you in troubleshooting the valve assembly in an efficient manner.

- Leakage at Barrel Ends: Tighten Tie Rod Nuts of replace seals (77).
- Noise During Operation: A creaking noise during air operation indicates a lack of lubrication (dry air). Add lubrication to the air supply of spray some oil into the cylinder ports.
- Valve Leaks when Closed: Adjust the closed stop (7). Adjust bolts 1/4 turn at a time.
- Valve does not Open: Verify cylinder pressure with a pressure gage. The valve documentation should indicate the minimum operating pressure (typically 80 psig).
- Leaking Oil at Fitting: Tighten cylinder fittings. Add thread sealant (Loctite PST) or Teflon Tape if needed.

DISASSEMBLY

Disassembly may be required to repair or rebuild the actuator. Work should be performed by a skilled mechanic with proper tools. The actuator can be disassembled while on the valve if the line is drained to prevent valve motion. Valve must be removed from the pipeline for disassembly. The actuator can be removed with the valve in the line (the line must be drained) or after the valve is removed from the line.

WARNING: Open valve and drain line before removing or repairing actuator or the valve or actuator may suddenly move causing injury or fluid loss. Place valve in closed position to remove the actuator.

Refer to Figure 2 for construction and parts.

1. Remove the cylinder pressure and drain the cylinder.

WARNING: The cylinder supply must be removed and cylinder drained before working on the cylinder or bodily injury or damage to property may result.

2. Remove the tie rod nuts (69).
3. Pull the Support Plate (62), Cap (64), and barrel (60).
4. Use a spanner wrench to remove the piston (65) from the rod (66).
5. Remove the cylinder head (63) together with the rod gland assembly (67).
6. Remove the Mounting Plate Bolts (15A) and remove mounting plate (15).
7. Remove the actuator indicator (19), and cover (2).
8. Remove the crosshead pin (12A). The rod (66) can now be pulled through the crosshead and lever (4).
9. Remove the actuator mounting bolts and lift actuator from valve taking care not to lose key.
10. Clean and inspect parts. Replace worn parts as necessary and lubricate parts with EP-2 grease.

REASSEMBLY

All parts must be cleaned and gasket surfaces should be cleaned with a stiff wire brush in the direction of the serrations or machine marks. Worn parts, gaskets and seals should be replaced during reassembly.

1. Install actuator housing with lever in place over valve shaft and secure to valve. Actuator mounting bolts should be lubricated and torqued per the Torque Table during reassembly.
2. Insert rod (66) through crosshead and secure to crosshead with pin (12A).
3. Install mounting plate (15) over the rod and on side of actuator housing.
4. Assemble the rod gland assembly (67) and cylinder head (63).
5. Thread the piston (65) onto the rod. Install new seals (75) and wear strip (76) on the OD of the piston.
6. Slide barrel (60) over piston and over cylinder head (63).
7. Secure with the Cap (64), Support Plate (62), and tie rods (68) and nuts (69). Torque per table.

8. Install actuator cover (2) and indicator (19).
9. Pipe supply pressure to cylinder. Stroke cylinder closed. Adjust actuator stop bolt (7) so that valve is closed and seals tight. See valve instruction manual if valve adjustments are needed.

PARTS AND SERVICE

Parts and service are available from your local representative or the factory. Make note of the valve Size, Series No, and Serial No. located on the valve nameplate and contact:

Val-Matic Valve and Mfg. Corp.
905 Riverside Drive
Elmhurst, IL 60126
PH: 630 / 941-7600
FAX: 630 / 941-8042

A sales representative will quote prices for parts or arrange for service as needed.

LIMITED WARRANTY

All products are warranted to be free of defects in material and workmanship for a period of one year from the date of shipment, subject to the limitations below.

If the purchaser believes a product is defective, the purchaser shall: (a) Notify the manufacturer, state the alleged defect and request permission to return the product; (b) if permission is given, return the product with transportation prepaid. If the product is accepted for return and found to be defective, the manufacturer will, at his discretion, either repair or replace the product, f.o.b. factory, within 60 days of receipt, or refund the purchase price. Other than to repair, replace or refund as described above, purchaser agrees that manufacturer shall not be liable for any loss, costs, expenses or damages of any kind arising out of the product, its use, installation or replacement, labeling, instructions, information or technical data of any kind, description of product use, sample or model, warnings or lack of any of the foregoing. NO OTHER WARRANTIES, WRITTEN OR ORAL, EXPRESS OR IMPLIED, INCLUDING THE WARRANTIES OF FITNESS FOR A PARTICULAR PURPOSE AND MERCHANTABILITY, ARE MADE OR AUTHORIZED. NO AFFIRMATION OF FACT, PROMISE, DESCRIPTION OF PRODUCT OF USE OR SAMPLE OR MODEL SHALL CREATE ANY WARRANTY FROM MANUFACTURER, UNLESS SIGNED BY THE PRESIDENT OF THE MANUFACTURER. These products are not manufactured, sold or intended for personal, family or household purposes.



VALVE AND MANUFACTURING CORP.

905 Riverside Dr. • Elmhurst, IL 60126
Phone (630) 941-7600 • Fax (630) 941-8042