

Val-Matic® 2"- 42" Sure Seal Foot Valve

Operation, Maintenance and Installation Manual

| | |
|-------------------------------|---|
| INTRODUCTION | 1 |
| RECEIVING AND STORAGE..... | 1 |
| DESCRIPTION OF OPERATION..... | 2 |
| VALVE CONSTRUCTION | 2 |
| INSTALLATION | 2 |
| MAINTENANCE | 3 |
| TROUBLESHOOTING | 3 |
| DISASSEMBLY | 4 |
| REASSEMBLY | 4 |
| PARTS AND SERVICE | 5 |
| WARRANTY | 5 |



VAL-MATIC® VALVE AND MANUFACTURING CORP.

905 Riverside Dr. • Elmhurst, IL 60126
Phone (630) 941-7600 • Fax (630) 941-8042
www.valmatic.com

2"-42" SURE SEAL FOOT VALVE OPERATION, MAINTENANCE AND INSTALLATION

INTRODUCTION

This manual will provide you with the information to properly install and maintain the valve to ensure a long service life. The Series 1900 Foot Valve is ruggedly constructed with bronze or stainless steel trim to give years of trouble free operation. The valve should be installed in a vertical suction pipe carrying clean water.

The Foot Valve is designed to open fully to provide flow in the forward direction and close rapidly upon flow reversal. The valves are used to prevent reverse flow and maintain the prime on pumps. The size, cold working pressure, and model number are stamped on the nameplate for reference.

This valve is not intended for fluids containing suspended solids such as wastewater. For wastewater and other high turbidity applications, use Val-Matic Series 500 Swing-Flex® Check Valves.

CAUTION

This valve is not intended for fluids containing suspended solids or hazardous fluids.

RECEIVING AND STORAGE

Inspect valves upon receipt for damage in shipment. Unload all valves carefully to the ground without dropping. When lifting, the valve should be secured by the body and never lifted by the basket or trim.

The valves should remain crated, clean and dry until installed to prevent weather related damage. For long term storage greater than six months, indoor storage is recommended. Do not expose the resilient seat to sunlight or ozone for any extended period.

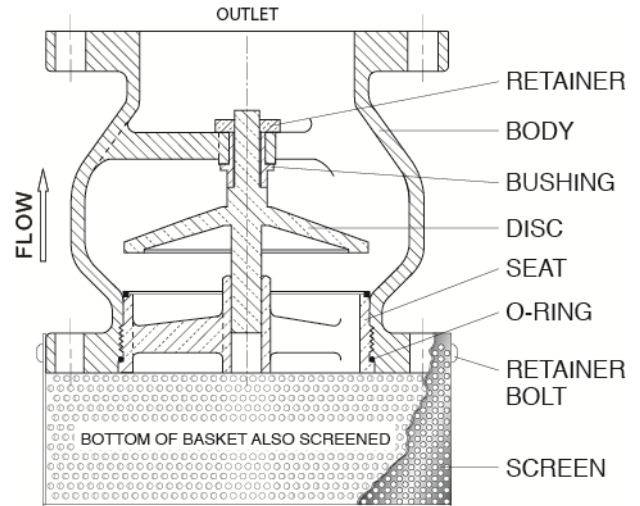

Sizes 2" to 12"

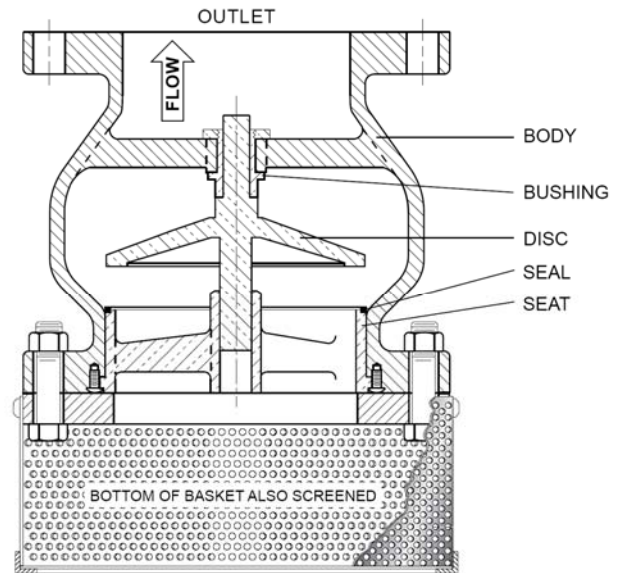

Sizes 14" and larger

FIGURE 1. FOOT VALVE WITH INLET SCREEN

DESCRIPTION OF OPERATION

As shown in Figure 1, the valve consists of a body, a disc, and a seat with a resilient seal. The valves are designed to prevent reverse flow and maintain a flooded suction when installed at the foot or end of the suction piping. The resilient seal provides drop-tight shutoff and the basket prevents debris from entering the valve and piping system.

The seat and seal are rigidly held in the bottom of the valve. As the flow enters the valve from the bottom, the disc is lifted by the flow and guided to the open positions by bushings in the body. Upon pump shut down, the return flow and weight of the disc close the valve rapidly and maintain the pump prime.

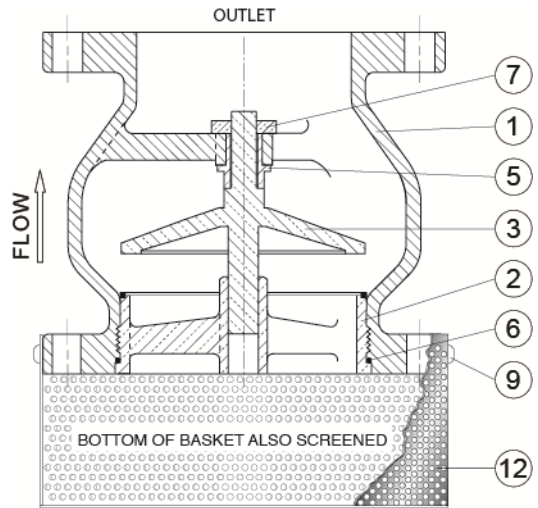

Sizes 14" and larger

VALVE CONSTRUCTION

The standard Series 1900 Foot Valve is constructed of rugged cast iron with a bronze or stainless steel trim. See the specific Materials List submitted for the order if other than standard cast iron construction. The details of construction are illustrated in Figure 2.

The body (1) is furnished with a flanged outlet for bolting to the suction piping. The body is equipped with a corrosion resistant seat (2). The disc (3) is guided by a bushing (7) fixed in the body. Leak-tight closure is made when the resilient seal located in the seat is compressed by the closed disc. A stainless steel basket assembly (12) prevents debris from entering the valve.

The only moving parts in the valve are the disc and spring. The body bushing controls the movement of the disc and assures that the plug contacts the seat evenly. The valve has a resilient seal for drop tight service.

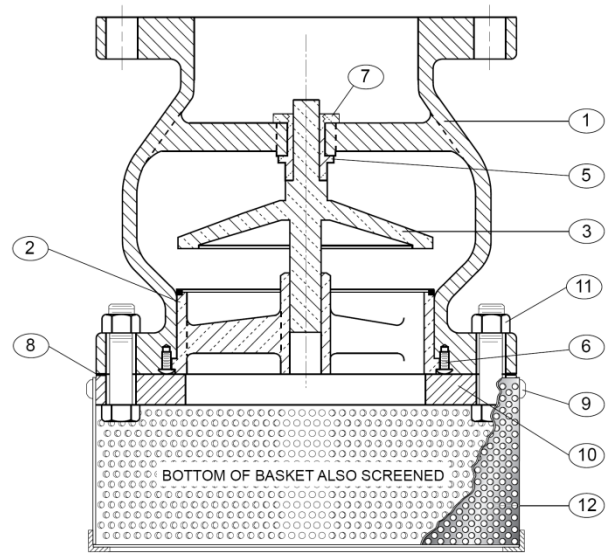

Sizes 14" and larger

FIGURE 2. FOOT VALVE CONSTRUCTION

INSTALLATION

The installation of the valve is important for its proper operation. Some general recommendations follow.

The flow direction is vertical flow up. Orient the valve so that the basket is in the wet well or water source. The basket lower surface should be at least .75 times the valve diameter from the bottom of the wet well floor or consult the pump manufacturer for direction.

CAUTION

Do not install the valve in horizontal piping or slamming may result.

The valve should be mated to ANSI Class 125# flat-faced flanges equipped with resilient gaskets. When ring gaskets are used, the bolt material shall be ASTM A307 Grade B or SAE Grade 2 Carbon Steel. Higher strength bolts may only be used with full-face gaskets.

CAUTION

Mating flanges must be flat faced or damage to the valve may result.

Lower valve into line using slings or chains around the valve body. Lubricate the flange bolts or studs and insert them around the flange. Lightly turn bolts until gaps are eliminated. Recommended lubricated torques for use with resilient gaskets (75 durometer) is given in Table 1.

The torquing of the bolts should then be done in graduated steps using the cross-over tightening method. If leakage occurs, allow gaskets to absorb fluid and check torque and leakage after 24 hours. Do not exceed bolt rating or crush gasket more than 50 percent of its thickness.

| 125# FLANGE DATA | | | 250# FLANGE DATA | | |
|------------------|----------------|----------------------|------------------|----------------|----------------------|
| Valve Size (in) | Bolt Dia. (in) | Bolt Torque (ft-lbs) | Valve Size (in) | Bolt Dia. (in) | Bolt Torque (ft-lbs) |
| 2 | 5/8 | 25-75 | 2 | 5/8 | 25-75 |
| 2.5 | 5/8 | 25-75 | 2.5 | 3/4 | 25-75 |
| 3 | 5/8 | 25-75 | 3 | 3/4 | 35-75 |
| 4 | 5/8 | 30-90 | 4 | 3/4 | 50-150 |
| 5 | 3/4 | 30-90 | 5 | 3/4 | 70-150 |
| 6 | 3/4 | 30-90 | 6 | 3/4 | 70-150 |
| 8 | 3/4 | 40-120 | 8 | 7/8 | 90-200 |
| 10 | 7/8 | 45-150 | 10 | 1 | 110-300 |
| 12 | 7/8 | 65-200 | 12 | 1 1/8 | 160-450 |
| 14 | 1 | 80-250 | 14 | 1 1/8 | 140-450 |
| 16 | 1 | 90-300 | 16 | 1 1/4 | 180-600 |
| 18 | 1 1/8 | 100-350 | 18 | 1 1/4 | 190-600 |
| 20 | 1 1/8 | 120-450 | 20 | 1 1/4 | 220-600 |
| 24 | 1 1/4 | 150-500 | 24 | 1 1/2 | 350-900 |
| 30 | 1 1/4 | 180-600 | 30 | 1 3/4 | 500-1500 |
| 36 | 1 1/2 | 250-750 | 36 | 2 | 700-2000 |
| 42 | 1 1/2 | 300-900 | 42 | 2 | 800-2500 |

TABLE 1. FLANGE BOLT TORQUES

MAINTENANCE

The Series 1900 Foot Valve requires no scheduled lubrication or maintenance. If flow is stopped or pump cavitation becomes apparent, it may be necessary to flush debris from the valve inlet by backflushing the valve or physically cleaning the outside surfaces of the basket.

WARNING

The basket flange (10) cannot be removed with water pressure on the valve or the seat may become dislodged causing damage or injury.

| ITEM | DESCRIPTION | MATERIAL |
|----------------|----------------|-------------------------|
| 1 | Body | Cast Iron |
| 2 | Seat* | Bronze (with Buna-N) |
| 3 | Disc* | Bronze |
| 5 | Bushing* | Bronze |
| 6 ¹ | O-Ring* | EPDM |
| 6 ² | Screw* | Stainless Steel |
| 7 | Retainer* | Brass |
| 8 | Gasket* | Fiber |
| 9 | Retainer Bolt* | Stainless Steel |
| 10 | Ring Plate | Steel |
| 11 | Bolt Assembly* | Steel, Plated |
| 12 | Screen* | Stainless Steel |

1. Sizes 2"-12"
2. Sizes 14" and larger
*Recommended Spare Part

TABLE 2. FOOT VALVE PARTS LIST

TROUBLESHOOTING

Several problems and solutions are presented below to assist you in trouble shooting the valve assembly in an efficient manner.

- **Leakage at Flanges:** Tighten flange bolts, replace gasket.
- **Valve Leaks When Closed:** Flush debris from seat by cycling pump three times. If the valve continues to leak after adjustment, check for the following items and make the corrections.
 1. Verify that there is no damage to the rubber seat. Replace if torn or damaged.
 2. Check that the metal seat in the body is clean and free of scale and scratches.

3. Verify that the test pressure is less than the cold working pressure (CWP) shown on the valve nameplate.
4. Drain wet well with pressure on valve and check basket flange seal. Tighten basket flange bolts or replace gasket.

- **Valve Slams:** If adjustable pump, add time to the shut down sequence. Check for trapped air in the pump header, Check interior of valve bushing for deposits or debris.
- **Noisy Operation of Pump:** Flow noise is normal. Loud flow noise similar to hammering may be cavitation from dropping high pressures suction piping. Check for debris on outside surfaces of basket or floor of wet well.

DISASSEMBLY

The valve should be removed from the pipeline for disassembly. All work on the valve should be performed by a skilled mechanic with proper tools. Refer to Figure 2.

WARNING

The line must be drained before removing the valve or pressure may be released causing injury.

1. Remove the basket screen (12) by removing the retainer screws (9).
2. For sizes 14" and larger, remove the ring plate (10) with the large bolts (11).
3. For sizes 2" to 12", unthread the seat (2) from the body (1) in a counterclockwise direction. For Sizes 14" and larger, remove seat screws (6) and remove the seat (2). Inspect resilient seal for damage.
4. Remove the disc (3) and inspect the seating surface for scoring or damage.
5. Remove the bushing nut (7) and bushing (5). Inspect for wear or damage. The bushing should be at least 1/32 in. larger in diameter than the disc stem.

Clean and inspect parts. Replace worn parts as necessary and lubricate parts with FDA grease

REASSEMBLY

All parts must be clean and gasket surfaces should be cleaned with a stiff wire brush in the direction of the serrations or machine marks. Worn parts, gaskets, and seals should be replaced during reassembly.

1. Install bushing (5) and nut (7) in body (1) with a bead of Loctite 680 retaining compound.
2. Install disc (3) and seat (2) in body. On sizes 14" and larger, secure with retaining bolts (6).
3. Install ring plate (10) with gasket (8) and with large flange bolts (11).
4. Install basket assembly (12) to ring flange with button head screws (9).
5. Install completed valve in pipeline with outlet flange and full-faced gasket.

PARTS AND SERVICE

Parts and service are available from your local representative or the factory. Make note of the Valve Size and Model Number located on the valve nameplate and contact:

Val-Matic Valve and Manufacturing Corp.
905 Riverside Drive
Elmhurst, IL 60126
Phone: (630) 941-7600
Fax: (630) 941-8042
www.valmatic.com

A sales representative will quote prices for parts or arrange for service as needed.

LIMITED WARRANTY

All products are warranted to be free of defects in material and workmanship for a period of one year from the date of shipment, subject to the limitations below.

If the purchaser believes a product is defective, the purchaser shall: (a) Notify the manufacturer, state the alleged defect and request permission to return the product; (b) if permission is given, return the product with transportation prepaid. If the product is accepted for return and found to be defective, the manufacturer will, at his discretion, either repair or replace the product, f.o.b. factory, within 60 days of receipt, or refund the purchase price. Other than to repair, replace or refund as described above, purchaser agrees that manufacturer shall not be liable for any loss, costs, expenses or damages of any kind arising out of the product, its use, installation or replacement, labeling, instructions, information or technical data of any kind, description of product use, sample or model, warnings or lack of any of the foregoing. NO OTHER WARRANTIES, WRITTEN OR ORAL, EXPRESS OR IMPLIED, INCLUDING THE WARRANTIES OF FITNESS FOR A PARTICULAR PURPOSE AND MERCHANTABILITY, ARE MADE OR AUTHORIZED. NO AFFIRMATION OF FACT, PROMISE, DESCRIPTION OF PRODUCT OF USE OR SAMPLE OR MODEL SHALL CREATE ANY WARRANTY FROM MANUFACTURER, UNLESS SIGNED BY THE PRESIDENT OF THE MANUFACTURER. These products are not manufactured, sold or intended for personal, family or household purposes.



VAL-MATIC® VALVE AND MANUFACTURING CORP.

905 Riverside Dr. • Elmhurst, IL 60126
Phone (630) 941-7600 • Fax (630) 941-8042
www.valmatic.com