

Val-Matic® 30" and Larger Butterfly Valve With LSA Actuator and External Stops

Operation, Maintenance and Installation Manual

INTRODUCTION	1
RECEIVING AND STORAGE	1
DESCRIPTION OF OPERATION	1
VALVE CONSTRUCTION	2
INSTALLATION	3
MAINTENANCE.....	6
TROUBLESHOOTING.....	9
DISASSEMBLY	10
REASSEMBLY	10
PARTS & SERVICE.....	12
WARRANTY	12



VALVE AND MANUFACTURING CORP.

905 Riverside Dr. • Elmhurst, IL 60126
Phone (630) 941-7600 • Fax (630) 941-8042
www.valmatic.com

VAL-MATIC 30" and Larger SERIES 2000 BUTTERFLY VALVE OPERATION, MAINTENANCE AND INSTALLATION

INTRODUCTION

The Series 2000 Butterfly Valve has been designed to give years of trouble-free operation. This manual will provide you with the information to properly install and maintain the valve to ensure a long service life. The valve is a resilient seated, quarter-turn valve capable of handling air, water, or other clean fluids. For fluids with suspended solids, a Model 5800R Eccentric Plug Valve should be used. The Size, Cold Working Pressure (CWP), and Model No. are stamped on the nameplate for reference.

CAUTION

Do not use valve for line testing at pressures higher than nameplate rating or leakage and damage to valve may occur.

The "Cold Working Pressure" is the non-shock pressure rating of the valve at 150°F. The valve is intended for flow in either direction. The "Seat End" is marked on the nameplate so that access to the seat can be assured.

RECEIVING AND STORAGE

Inspect valves upon receipt for damage in shipment. Unload all valves carefully to the ground without dropping. Do not lift valves with slings or chains around the actuator or through the seat area. Extra care must be taken when handling electric motor and cylinder actuated valves.

Valves should remain crated, clean and dry until installed to prevent weather related damage. For long term storage greater than six months, indoor storage is recommended. The valve flange covers must remain in place, the valve must remain slightly open (3-5 degrees), and the rubber surfaces of the disc should be coated with a thin film of FDA approved grease such as Dow Corning # 7. Do not expose the resilient seat to sunlight or ozone for any extended period. Electric actuators must be powered if stored outdoors or in cool areas so that the internal heaters will prevent condensation in the control unit.

DESCRIPTION OF OPERATION

As shown in Figure 1, the valve consists of a body, a disc, and a shaft that rotates in body bearings. The resilient seat provides drop-tight shutoff.

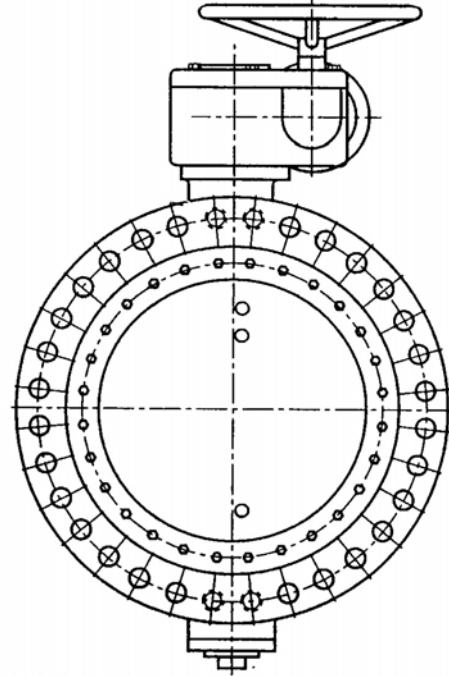

FIGURE 1. BUTTERFLY VALVE WITH ACTUATOR

The disc is rigidly attached to the shaft with taper pins. The actuator rotates the valve shaft and disc through 90 degrees of operation. The disc can rotate through the seat, but is factory set to stop in the center of the seat to provide tight shut off. Additional torque on the actuator when against the closed stop of the actuator will not provide tighter shut off. The valve seat is easily adjustable or replaceable should wear or damage occur over time.

The valve is typically operated with a manually operated gear actuator. The gear actuator as shown in Figure 1 requires multi-turn input on a 2" square nut, handwheel, or chainwheel. The valve can also be automated with power actuators such as an electric motor or hydraulic cylinder.

VALVE CONSTRUCTION

The standard Series 2000 Butterfly Valve is constructed of rugged cast iron with a stainless steel shaft and resilient disc edge. See the specific Materials List submitted for the order if other than standard cast iron construction. The details of construction are illustrated in Figure 2.

The body (1) is available with flanged or mechanical joint ends for connection to the pipeline. The body is equipped with a stainless steel seat (2). The 1/4 turn disc (3) is guided by a stainless steel shaft (4) which rotates in non-metallic bearings (5) fixed in the body. Leak-tight closure is made when the resilient seat (6) is rotated into the stainless steel seat on the "SEAT END" of the body.

Item	Description	Material
1	Body	Gray or Ductile Iron
2	Body Seat	Stainless Steel
3	Disc	Ductile Iron
4	Shaft	Stainless Steel
5	Sleeve Bearing*	Teflon/Fiberglass
6	Resilient Seat*	Buna-N
7	Seat Retaining Ring	Stainless Steel
8	Ret. Ring Screws*	Stainless Steel
9	Taper Pin	Stainless Steel
10	Taper Pin O-Ring*	Buna-N
11	Taper Pin Nut	Stainless Steel
12	Taper Pin Washer	Stainless Steel
13	Packing*	Buna-N
14	Key	Carbon Steel
15	Thrust Bearing Cap	Ductile Iron
16	Cap Screws	Carbon Steel, Plated
18	Thrust Plate	Cast Iron
19	Thrust Plate Bolt	Carbon Steel, Plated
20	Thrust Plate Gasket	Non-Asbestos Fiber
21	Lock Cap	Cast Iron
22	Lock Cap Bolts	Carbon Steel, Plated
23	Lock Cap Gasket	Non-Asbestos Fiber
24	Body O-Ring	Buna-N

*Recommended Spare Part

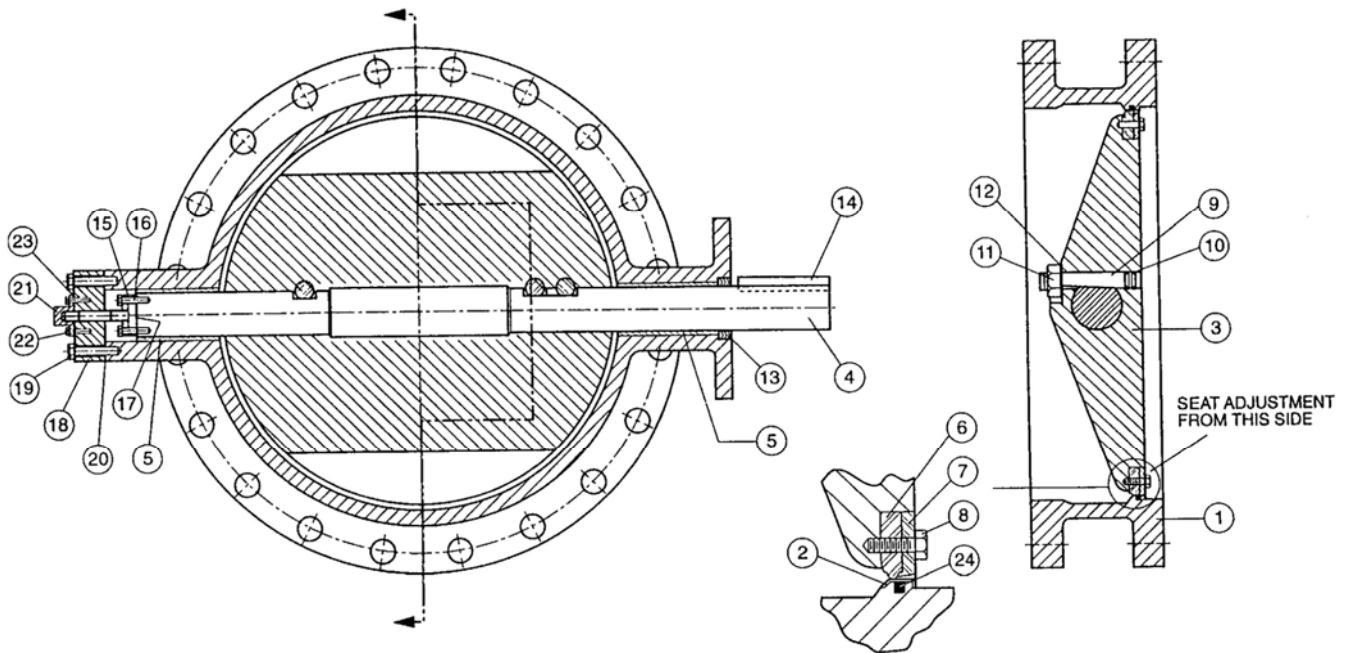

FIGURE 2. STANDARD BUTTERFLY VALVE CONSTRUCTION#

INSTALLATION

The Val-Matic Butterfly Valve is Bi-Directional, however, when deciding the valve's installation orientations, the engineer should consider the seat position in regards to flow and access. The following guidelines are intended to assist the engineer. The "**SEAT END**" and "**SUGGESTED FLOW**" are marked on the valve nameplate, which is mounted on the flange O.D. The seat end identifies which end the seat can be adjusted from when the valve is closed. The flow direction may affect valve torque for large valves. Some specific piping problems are also shown in the figures to the right.

GENERAL PIPELINE APPLICATIONS: Orient the "**Seat End**" towards the access point (i.e. manway, pipe coupling, or spool).

WATER SERVICE: The normal flow direction is towards the seat end of the valve. When the flow stops, the return pressure will be held by the closed disc and the seat bolts (8) can be adjusted to provide tight shut off should the seat be worn or damaged. The normal flow direction and the words "**SEAT END**" are marked on the nameplate.

AIR AND GAS SERVICE: Install valve with pressure toward the end opposite the "**Seat End**". Lubricate resilient seat with FDA approved silicone grease such as Dow Corning #7 before installation. Gear actuators are recommended for gas service applications.

PUMP DISCHARGE SERVICE: On all horizontal pump discharge applications (Figure 3), the "**Seat End**" should be towards the pump. The valve will seal tightly against return flow allowing seat adjustment if necessary. The valve shaft should be oriented parallel to the plane of the pump discharge elbow (i.e. vertical valve shaft on a vertical discharge elbow). If the butterfly valve is downstream of a check valve, the clearance between the two discs must be checked. The butterfly valve shaft should be oriented as shown in Figure 4.

BURIED SERVICE: The valve should be installed with the shaft horizontal and the actuator nut directed upwards (Figure 4). The valve box or extension pipe should be installed so that the actuator nut and extension stem turn freely.

CAUTION

Adjacent pipe must be supported or stiffened to provide a round mating connection for the valve in service.

FLANGED ENDS: AWWA Class 150B flanged valves should be mated to ANSI Class 125# or AWWA C207 flat-faced flanges equipped with resilient gaskets. When ring gaskets are used, the bolt material shall be ASTM A307 Grade B or SAE Grade 2 Carbon Steel. Higher strength bolts may only be used with full-face gaskets.

Some of the flange holes are tapped near the shaft ends of the valve as shown on the Sales Drawing. Special bolt lengths may be needed. An engagement of at least one bolt diameter is typically used for the flange bolts used in the tapped flange holes.

AWWA Class 250B flanged valves can be mated with either ANSI Class 125#, ANSI Class 250# or AWWA C207 flanges depending on the specified flange drilling. Class 250B valves can be mated with flat-faced or raised-face flanges with full face or ring gaskets and with no bolting restrictions.

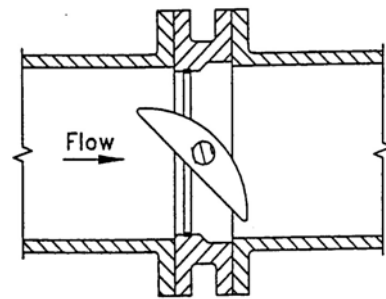

Flow Towards Seat End #
FIGURE 3. PUMP DISCHARGE

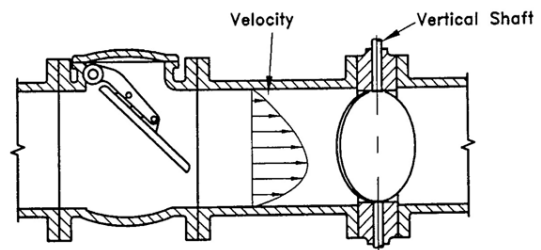

FIGURE 4. UPSTREAM CHECK VALVE

In all installations, the valve and adjacent piping must be supported and aligned to prevent cantilevered stresses on the valve. Lower valve into line using slings or chains around the valve body. Lubricate the flange bolts or studs and insert them around the flange. Lightly turn bolts until gaps are eliminated.

INSTALLATION (Cont'd)

Table 2. Minimum Pipe I.D. to Clear Flanged BFV			
Size	Min. I.D.	Size	Min.I.D.
30"	27.9"	72	70.0"
36"	34.8"	78	74.9"
42"	40.5"	84	81.0"
48"	45.8"	90	86.8"
54"	52.1"	96	92.7"
60"	58.2"	102	98.5"
66"	63.7"	108	104.4"

#

Table 3. Minimum Pipe I.D. to Clear Mechanical Joint BFV Disc			
Size	Min. I.D.	Size	Min.I.D.
30"	28.33"	42"	40.42"
36"	34.29"	48"	46.21"

The torquing of the bolts should then be done in graduated steps using the cross-over tightening method. Recommended lubricated torques for use with resilient gaskets (75 durometer) are given in Table 4. If leakage occurs, allow gaskets to absorb fluid and check torque and leakage after 24 hours. Do not exceed bolt rating or crush gasket more than 50 percent of its thickness.

Table 4. Flange Bolt Torques			
150B Flange Bolt Torques			
Valve Size (in)	Bolt Dia (in)	Recom Torque (ft-lbs)	Max Torque (ft-lbs)
30	1 ¼	175	600
36	1 ½	175	1000
42	1 ½	200	1000
48	1 ½	250	1000
54	1 ¾	300	1500
60	1 ¾	350	1500
66	1 ¾	400	1500
72	1 ¾	400	1500
78	2	500	2000
84	2	600	2000
90	2 ¼	750	3000
96	2 ¼	1000	3000
102	2 ½	1000	4000
108	2 ½	1200	4000

CAUTION

The use of raised-face flanges or excessive bolt torque may damage valve flanges.

300# Flange Bolt Torques			
Valve Size (in)	Bolt Dia (in)	Recom Torque (ft-lbs)	Max Torque (ft-lbs)
30	1 ¾	400	1200
36	2	600	1800
42	2	750	2250
48	2	750	2250
54	1 ¾	750	1500
60	1 ¾	750	1500
66	1 ¾	750	1500
72	1 ¾	750	1500
78	2	1000	2500
84	2	1000	2500
90	2 ¼	1500	3500
96	2 ¼	1500	3500
102	2 ½	1500	4500
108	2 ½	1800	4500

MECHANICAL JOINT ENDS: Clean ends of mating pipe and valve sockets with soapy water (Figure 5). Place lubricated gasket and retainer gland over pipe end prior to installing valve. Install valve socket over pipe. Press gland and gasket toward valve until gasket is evenly set into valve socket.

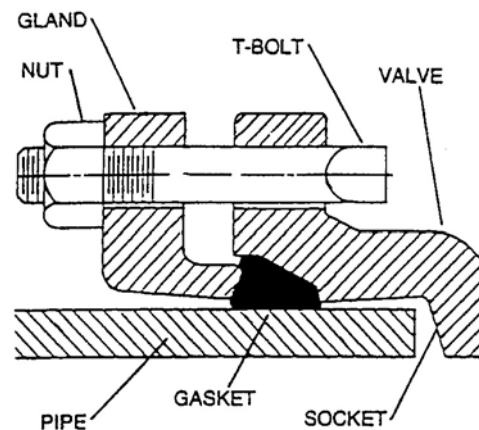

FIGURE 5. MECHANICAL JOINT INSTALLATION

Insert T-bolts in valve flange and hand tighten nuts. Torque nuts in four graduated steps using the cross-over tightening method without exceeding the torque listed in Table 5. Maintain an equal gap between the gland and the face of the valve at all points around the socket.

If a tight connection is not achieved, then the joint should be disassembled, thoroughly cleaned, and reassembled. Over-tightening, may cause damage to the valve or gland.

Table 5. Mechanical Joint Nut Torques			
Valve Size (in)	T-Bolt Dia (in)	Recom Torque (ft-lbs)	Max Torque (ft-lbs)
30	1	75	120
36	1	75	120
42	1 1/4	75	150
48	1 1/4	75	150

GEAR OPERATED VALVES: Butterfly Valves are available with a two types of manual gear actuator.

A **worm-gear actuator** (Figure 6) has a multi-turn worm that drives a large sector gear through 90 degrees of rotation. Worm gears provide uniform motion and torque multiplication throughout the stroke. A spur gear mounted on the input side provides additional torque.

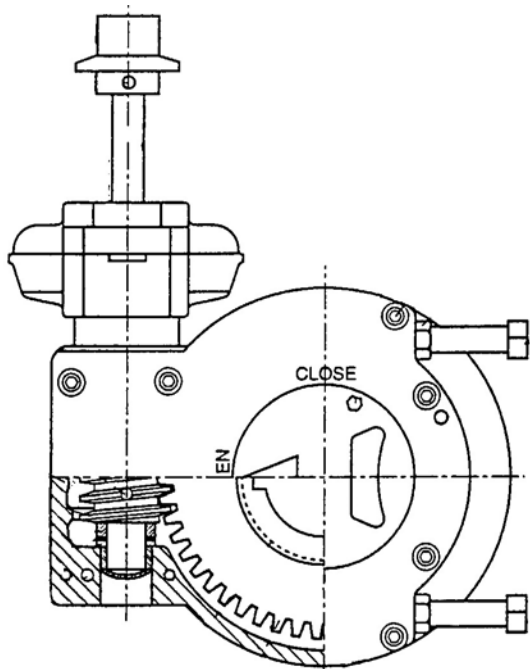

FIGURE 6. WORM GEAR ACTUATOR

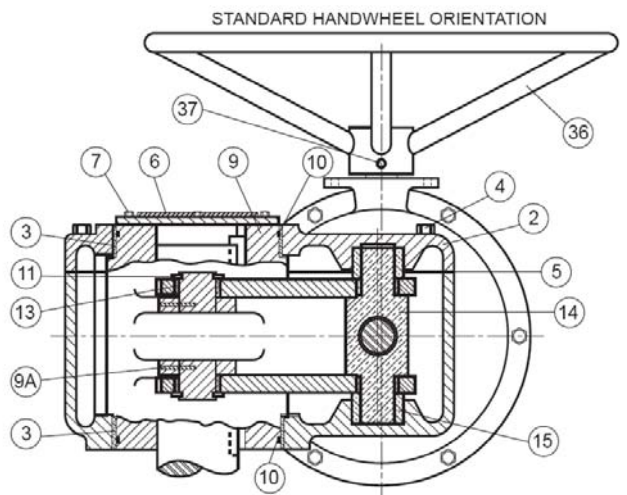
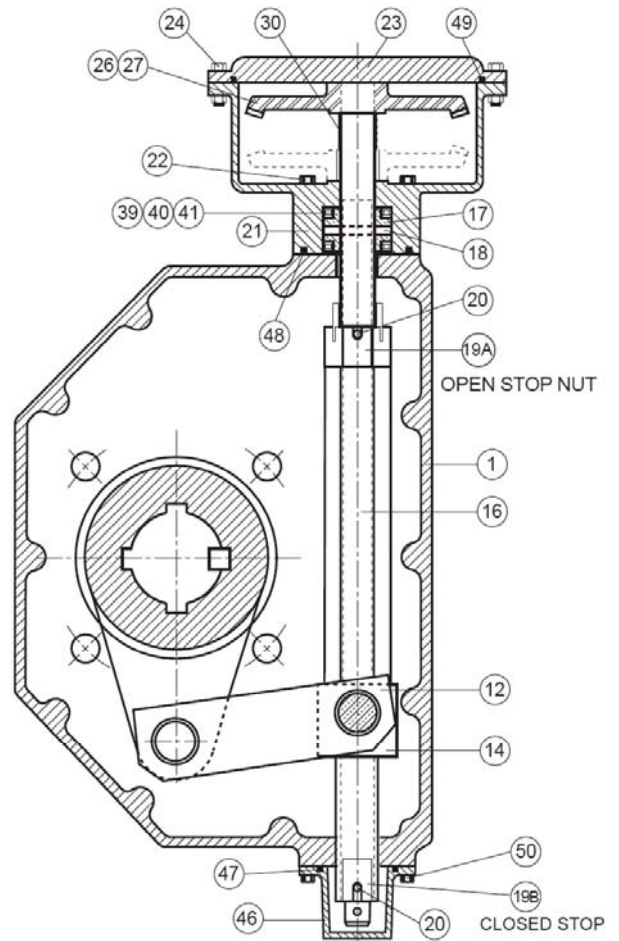

FIGURE 7. TRAVELING NUT ACTUATOR

CAUTION

Opening and Closing of the valve should be done slowly to prevent water hammer.

A traveling **nut actuator** (Figure 7) has a threaded rod (16) that drives a threaded crosshead (14) from one end of the housing to another. The crosshead in turn drives a slotted lever (9) through 90 degrees of rotation. Traveling nut actuators provide slower rotation and greater torque multiplication at the ends of travel. A bevel gear mounted on the input side of the actuator provides additional torque.

Both worm gear and traveling-nut actuators are self-locking and multiply the turning force on the handwheel or nut so that valves can be operated with ease. A clamp-on chainwheel kit can also be used for installations high above the floor. An indicator on the top of the actuator housing indicates the position of the valve plug. The handwheel or nut must be rotated through 35-290 turns (depending on model) to open or close the butterfly valve. The direction of rotation to open the valve is indicated on the 2" square actuator nut and handwheel. The standard direction of rotation is open left or counter-clockwise to open. Nuts with opposite rotation (open right) will be painted red to indicate their special rotation.

GEAR ACTUATOR ADJUSTMENT: The standard gear actuator is provided with factory-set open and closed position stops to properly center the closed disc seal in the body seat. No field adjustment is necessary. If adjustment is needed over time, the external closed stop nut (19B) can be turned to change the closed position of the valve.

VALVE SEAT ADJUSTMENT: If the valve is found to leak in service, the rubber seat can be adjusted. With the valve in the closed position, tighten the three seat bolts in the area of the leak 1/4 turn at a time until the leak stops.

The initial factory settings for the seat bolts are given in Table 6 for reference in case the valve cannot be tested while under pressure. These torques are for use with the disc in the closed position at the time of seat installation. Torques greater than 150% of these will make the valve difficult to operate.

Table 6. Initial Seat Bolt Torques		
Sizes	Class 150B	Class 250B
30"	20 ft-lbs	24 ft-lbs
36"-48"	26 ft-lbs	30 ft-lbs
54"-108"	30 ft-lbs	50 ft-lbs

MAINTENANCE

For water service, the Series 2000 Butterfly Valve requires no scheduled lubrication or maintenance other than regular exercising. The exercising is achieved by fully opening and closing the valve to verify smooth operation. If operation is difficult, it may be necessary to flush sediment from the valve by opening and closing the valve several times under flowing conditions or checking the lubricant in the gear actuator. For valves in air service, apply a thin film of FDA silicone grease such as Dow Corning #7 to the exposed rubber surface once per year.

The recommended interval for exercising is every six months or annually if the valve is regularly operated. Over the life of the valve, inspection and some regular adjustments may be needed as given below.

PACKING ADJUSTMENT: The shaft is equipped with a set of V-shaped packing, which is factory-set for drop-tight service. The packing is pressure assisted and does not normally require adjustment. Should leakage occur, the packing can be replaced.

PACKING REPLACEMENT: To replace the packing, it is recommended that the line be drained and the actuator removed. The valve can remain in the line.

1. To replace the packing, first open the valve and drain the line.

WARNING

Drain Line and close valve before removing actuator or valve may rotate suddenly causing bodily injury or damage to property.#

2. Close the valve to hold the plug in position. For power actuators, turn off and lock out electrical and hydraulic supplies before proceeding.
3. Remove small round cover on actuator to expose shaft and key.
4. Remove actuator mounting bolts and adapter plate or packing retainer plate.
5. Lift actuator and plates from valve taking care not to lose square key.
6. Remove old packing (13) with packing hook.
7. Lubricate new packing with FDA grease and set in place one ring at a time taking care not to bend over the lips of the packing rings.

8. Reinstall actuator mounting plates. Clean off all grease from the surfaces of the actuator mounting surfaces.
9. With valve in the closed position, place actuator over valve and reinsert key (14).
10. Finally, with valve closed, install cover on actuator indicating "Closed".

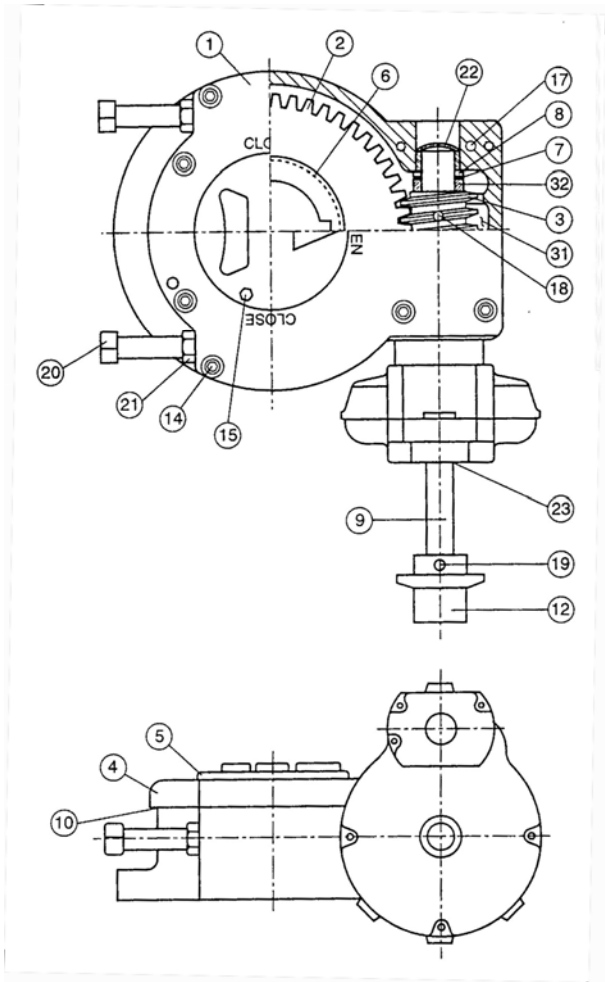

FIGURE 8. GEAR ACTUATOR CONSTRUCTION

Table 7. Worm Gear Parts List		
Item	Description	Material
1	Housing	Cast Iron
2	Segment Gear	Bronze or DI
3	Worm	Alloy Steel
4	Cover	Cast Iron
5	Indicator	Cast Iron
6	O-Ring	Buna-N
7	Thrust Bearing	Carbon Steel
8	Bearing	Bronze
9	Shaft	Carbon Steel
10	Gasket	Non-Asbestos
12	Operating Nut	Cast Iron
14	Cover Bolt	Carbon Steel
15	Indicator Bolt	Steel
17	Locating Pin	Steel
18	Worm Pin	Steel
19	Spring Pin	Steel
20	Stop Screw	Steel
21	Jam Nut	Steel
22	Plug	Steel
23	Oil Seal	Steel & Rubber
30	Spur Gear	Cast Iron
31	Grease	EP-2
32	Worm Spacer	Steel

WORM GEAR ACTUATOR MAINTENANCE: A typical worm gear actuator is shown in Figure 8 and consists of a worm (3) mounted on an input shaft (9). The worm engages a segment gear (2). When the worm is turned, it drives the segment gear through 90° of rotation. The rotation of the segment gear is displayed by the top indicator (5). The gears are lubricated with EP2 grease in a cast iron housing (1). The open and closed positions of the segment gear (2) are controlled by the end position stop bolts (20). The stops can be adjusted by loosening the lock nut (21) and rotating the bolts (20).

The gearbox is factory lubricated and sealed. No regular maintenance is required. If difficult operation is observed, the cover can be removed and the unit inspected for wear. All moving parts should be coated with grease. The grease should have an even and smooth consistency. If needed, coat all moving parts with an EP-2 grease such as Mobil Mobilux EP2. Buried units should be packed 90% with grease.

TRAVELING NUT ACTUATOR MAINTENANCE: A typical traveling nut actuator is shown in Figure 9 and consists of a threaded nut (12) which travels back and forth on a threaded stem (14). The stem is lubricated with EP2 grease in a cast iron housing (1). The nut, in turn, drives a slotted lever (4) through 90 degrees of travel. The lever (4) drives the valve shaft with a

square key. The rotation of the shaft is displayed by the top indicator (19). The full open and closed positions are controlled by the stop nuts (6). The stop nuts can be adjusted by pounding out the pin (7) with a drift punch and rotating the stop nut ½ turn. The gear box is factory lubricated and sealed. No regular maintenance is required. If difficult operation is observed, the cover can be removed and the unit inspected for wear. All moving parts should be coated with grease. The grease should have an even and smooth consistency. If needed, coat all moving parts with an EP-2 grease such as Mobil Mobilux EP2. Buried units should be packed 90% with grease.

CAUTION
Fill LSA Actuators with AT LEAST 90% grease prior to mounting electric motor actuators.

Table 8. Traveling Nut Actuator Parts		
Item	Description	Material
1	Housing	Cast Iron
2	Cover	Cast Iron
3	Bushings	Teflon / Fiberglass
4	Cover Bolts	Stainless Steel
5	Gasket	RTV Sealant
6	Indicator	Cast Iron
7	Indicator Bolt	Stainless Steel
8	Gasket	RTV Sealant
9	Lever	Ductile Iron
9A	Locking Pin	Alloy Steel
10	O-Ring	Buna-N
11	Retaining Ring	Steel
12	Link	Steel
13	Link Bushing	Teflon / Fiberglass
14	Crosshead	Bronze
15	Guides	Bronze
16	Shaft	Steel
17	Thrust Collar	Bronze
18	Thrust Collar Pin	Steel
19	Stop Nuts	Steel
20	Stop Nut Pins	Steel
21	Bevel Gear	Cast Iron
22	End Cap Bolts	Alloy Steel
33	Stem O-Ring	Buna-N
36	Handwheel	Steel or Cast Iron
37	Pin	Steel
39	Ball Bearings	Steel
40	Bearing Race	Steel
46	Stop Cover	Cast Iron
47	Cover O-Ring	Buna-N
48	End Cap O-Ring	Buna-N
50	Stop Cover Bolts	Stainless Steel

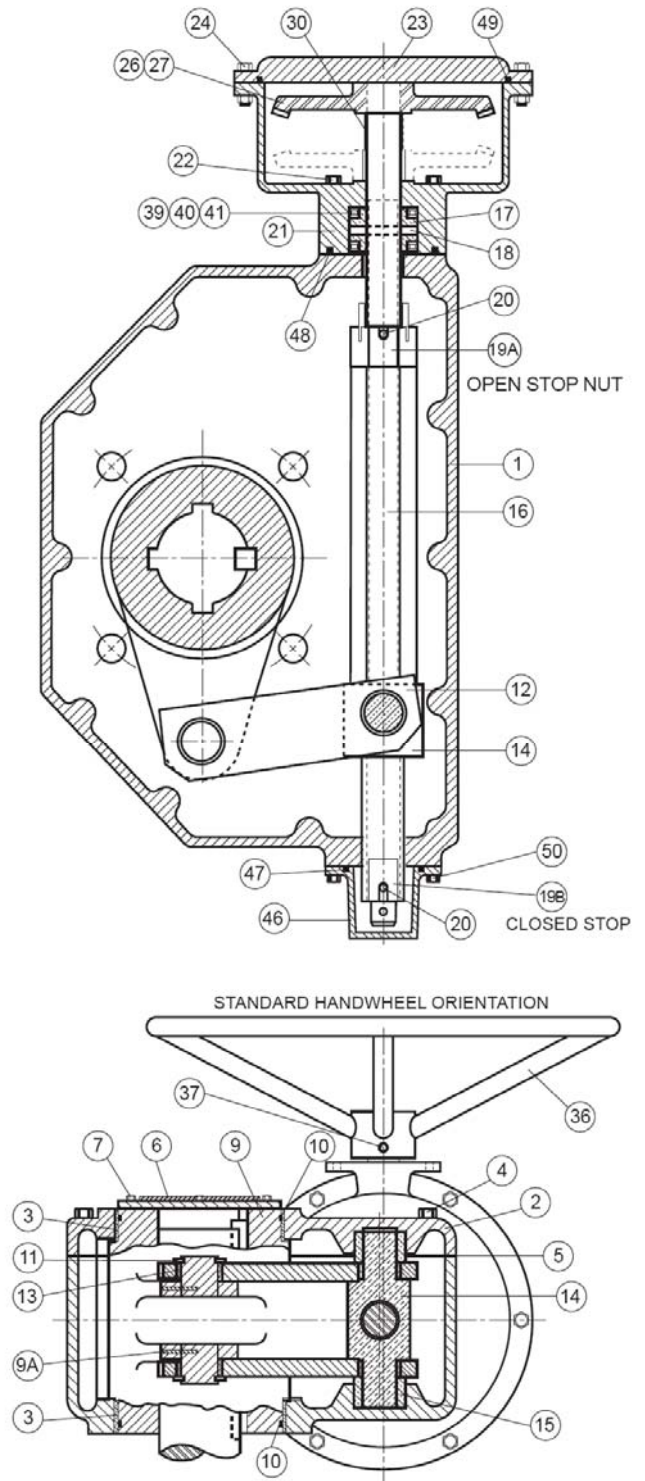

FIGURE 9. TRAVELING NUT ACTUATOR CONSTRUCTION

CHANGE OF ROTATION:

The traveling nut actuator with bevel gear can be changed in the field from open-right to open-left by inverting the bevel gear, refer to Figure 10.

1. Remove bevel gear housing cover and spacer.
2. Remove retaining ring and pull out input shaft assembly.
3. Remove pinion gear and key.
4. Pull bevel gear and key.
5. Reassemble input shaft assembly with pinion, key, and retainer ring.
6. Install spacer over shaft and then bevel gear and key.
7. Replace cover.

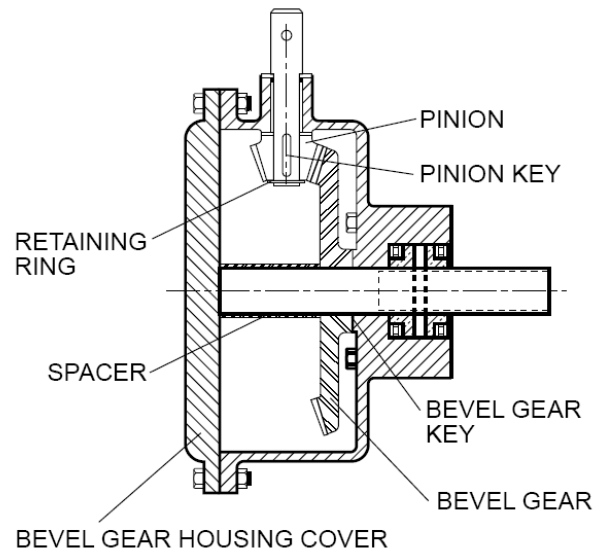

FIGURE 10. BEVEL GEAR (Open-Right)

Table 9. Bevel Gear Parts		
Item	Description	Material
21	Bevel Gear Housing	Cast Iron
22	Mounting Bolts	Steel
23	Cover	Cast Iron
24	Cover Bolts	Plated Steel
25	Gasket	Composition Rubber
26	Bevel Gear	Steel
27	Bevel Gear Key	Steel
28	Pinion Gear	Steel
29	Pinion Gear Key	Steel
30	Spacer	Steel
31	Input Shaft	Type 416 SS
32	Retaining Ring	Steel
33	O-Ring	Buna-N
34	Bearing	Bronze
35	2" Nut	Cast Iron
37	Pin	Steel
38	Thrust Washer	Bronze
39	Needle Bearing	Steel
40	Bearing Races	Steel
41	Shims	Steel

TROUBLESHOOTING

Several problems and solutions are presented below to assist you in troubleshooting the valve assembly in an efficient manner.

- Leakage at Valve Shaft: Replace packing.
- Leakage at Flanges: Tighten flange bolts, replace gasket.
- Valve Leaks when Closed: Flush debris from seat by cycling valve. Adjust actuator closed stop. Inspect seat for damage and adjust seat bolts 1/4 turn at a time.

If the valve continues to leak after adjustment, check for the following items and make the corrections.

1. Verify that there is no damage to the rubber seat. Replace if torn or damaged.
2. Check that the metal set in the body is clean and free of scale and scratches.
3. Check that the actuator is fully closed and the seal is centered in the body seat. Adjustment to the actuator stop nuts or bolts may be necessary.

TROUBLESHOOTING (Cont'd)

4. Check the roundness of the adjoining pipe and pipe flange. Pipe loads may cause distortion to the adjoining pipe and valve.
5. Verify that the test pressure is less than the cold working pressure (CWP) shown on the valve nameplate.
 - **Hard to Open:** Flush line of debris. Check grease in actuator. Check interior of valve for deposits or debris. On buried valves, check alignment of operating stem and nut.
 - **Leaking Oil:** Tighten actuator cover bolts. If leak persists, remove actuator cover, inspect grease, and replace actuator gasket.
 - **Noisy Operation:** Flow noise is normal. Loud flow noise similar to hammering may be cavitation from dropping high pressures across valve; review application of valve. For gear actuator noise, inspect grease; add new grease if there are uncoated moving parts or grease has broken down into oil.
 - **Valve does not Open:** Remove actuator cover and check internal parts. For mechanical joint valves, heavy wall PVC pipes may interfere with the disc. Chamfer pipe at 45 degrees.

DISASSEMBLY

Disassembly may be required to repair the valve. Work on the valve should be performed by a skilled mechanic with proper tools and a power hoist for large valves. The valve must be removed from the pipeline for disassembly. The actuator can be removed with the valve in the line (the line must be drained) or after the valve is removed from the line. Refer to Figure 14 for valve construction and parts.

WARNING

Open valve and drain line before removing actuator or the valve may suddenly open causing injury or fluid loss. Place valve in closed or slightly open position to remove from the line or damage to the disc edge may occur.#

1. Open valve slightly and drain the pipeline. Close valve until disc edge just touches the seat. Valve and actuator can be removed as a unit from the pipeline.

2. Remove the small cover on the actuator to expose the shaft key. Remove the actuator mounting bolts and lift actuator from valve taking care not to lose key (24). Access to the traveling nut actuator will be under the actuator cover.
3. Remove lock cap (21) and thrust plate (18) and thrust bearing cap (15). Remove the seat bolts (8) and seat retaining ring (7).
4. Matchmark the taper pins with the disc holes. Remove the taper pin nuts (11) and taper pins (9). Press or hammer out the shaft (4) with a dead blow hammer. The bearings (5) should not be removed unless the teflon liner is severely worn. To remove bearings, grind a slot along its length and hammer out with a sharp chisel.
5. Clean and inspect parts. Replace worn parts as necessary and lubricate parts with FDA grease.

REASSEMBLY

All parts must be cleaned and gasket surfaces should be cleaned with a stiff wire brush in the direction of the serrations or machine marks. Worn parts, gaskets and seals should be replaced during reassembly. The valve bolts should be lubricated and tightened per Table 10 during reassembly.

Size	Torque (ft-lbs)
1/2"-13	45-75
5/8"-11	100-150
3/4"-10	150-250
7/8"-9	200-350
1"-8	300-500
1 1/8"-7	450-700
1 1/4"-7	650-1000

1. Apply a bead of Loctite 680 on new bearings (5) and insert into both ends of the valve body (1) until flush with packing bottom surface. Insert the shafts (4) through the body and disc (3).
2. Install taper pins (9) with washers (12) and nuts (11).

REASSEMBLY (Cont'd)

3. Install new seat (6), retaining ring (7) and seat bolts (8) into disc. Apply thin film of FDA silicone grease such as Dow Corning #7 to rubber surface. Lightly tighten seat bolts until bolt heads touch ring.
4. Install thrust cap (15) and, thrust plate (18) with the appropriate gaskets and bolts. Turn the thrust bearing stud (17) until the disc is centered in the valve body seat. Install lock cap (21).
5. Lubricate ID and OD of packing set with FDA grease and install in packing bore one ring at a time taking care to keep lips pointing down toward valve.
6. Torque seat bolts to torque given in Table 6.
7. Insert key (24) into shaft and place actuator over valve. Reinstall actuator mounting bolts and torque per Table 7. Install cover on actuator. Cycle valve. Apply pressure to valve and check for seat leakage. Tighten seat bolts $\frac{1}{2}$ turn at a time as necessary.
8. If valve does not shut off tight, adjust the external closed position stops.

SEAT REPLACEMENT

If the seat is badly worn or damaged, gain access to valve interior and remove existing cap screws, seat retaining ring, and seat.

1. Clean mating surfaces of body seat, disc and retaining ring with stiff wire brush in the direction of the machine grooves.
2. Install new seat (6) onto disc so that the o-ring bead side is against the disc with the holes aligned.
3. Start at the top of the disc and install a section of retaining ring (7) with three new seat bolts (8) and lightly tighten seat bolts until the bolt heads touch the retaining ring.
4. Apply a thin film of FDA silicone grease such as Dow Corning #7 to the exposed rubber surface and close the valve so that the disc is level with the flange face with in $\pm \frac{1}{4}$ in.
5. Tighten the seat bolts in a crossover pattern in two steps to the torque given in Table 5 using a socket wrench. Do not attempt to re-tighten seat hex head cap screws to their initial torques at a later time.
6. Cycle valve open and closed and verify that disc closes within $\pm \frac{1}{4}$ in of center. Conduct a pressure test. If necessary, tighten seat bolts $\frac{1}{2}$ turn to stop any leakage.

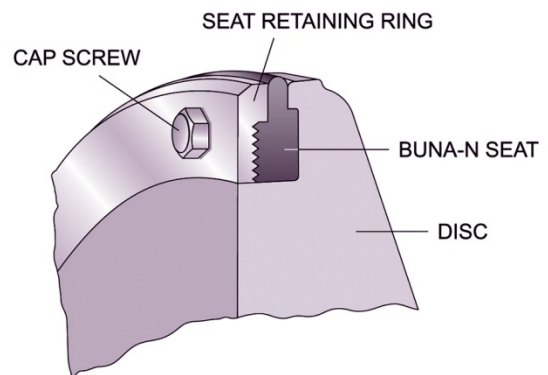

FIGURE 11. SEAT REPLACEMENT

PARTS AND SERVICE

Parts and service are available from your local representative or the factory. Make note of the valve Size, Model No, and Serial No. located on the valve nameplate and contact:

Val-Matic Valve and Mfg. Corp.
905 Riverside Drive
Elmhurst, IL 60126
Phone: (630) 941-7600
Fax: (630) 941-8042
www.valmatic.com

A sales representative will quote prices for parts or arrange for service as needed.

LIMITED WARRANTY

All products are warranted to be free of defects in material and workmanship for a period of one year from the date of shipment, subject to the limitations below.

If the purchaser believes a product is defective, the purchaser shall: (a) Notify the manufacturer, state the alleged defect and request permission to return the product; (b) if permission is given, return the product with transportation prepaid. If the product is accepted for return and found to be defective, the manufacturer will, at his discretion, either repair or replace the product, f.o.b. factory, within 60 days of receipt, or refund the purchase price. Other than to repair, replace or refund as described above, purchaser agrees that manufacturer shall not be liable for any loss, costs, expenses or damages of any kind arising out of the product, its use, installation or replacement, labeling, instructions, information or technical data of any kind, description of product use, sample or model, warnings or lack of any of the foregoing. NO OTHER WARRANTIES, WRITTEN OR ORAL, EXPRESS OR IMPLIED, INCLUDING THE WARRANTIES OF FITNESS FOR A PARTICULAR PURPOSE AND MERCHANTABILITY, ARE MADE OR AUTHORIZED. NO AFFIRMATION OF FACT, PROMISE, DESCRIPTION OF PRODUCT OF USE OR SAMPLE OR MODEL SHALL CREATE ANY WARRANTY FROM MANUFACTURER, UNLESS SIGNED BY THE PRESIDENT OF THE MANUFACTURER. These products are not manufactured, sold or intended for personal, family or household purposes.#



VAL-MATIC® VALVE AND MANUFACTURING CORP.

905 Riverside Dr. • Elmhurst, IL 60126
Phone (630) 941-7600 • Fax (630) 941-8042
www.valmatic.com#