

Electric Panel Pump Control System

Operation, Maintenance and Installation Manual

INTRODUCTION.....	1
RECEIVING AND STORAGE	1
DESCRIPTION OF OPERATION.....	1
INSTALLATION.....	2
SEQUENCE OF OPERATION	2
MAINTENANCE	4
TROUBLESHOOTING	4
DISASSEMBLY	4
REASSEMBLY	4
PARTS AND SERVICE	4
WARRANTY	5



VAL-MATIC® VALVE AND MANUFACTURING CORP.

905 Riverside Dr. • Elmhurst, IL 60126
Phone (630) 941-7600 • Fax (630) 941-8042
www.valmatic.com

ELECTRIC PANEL OPERATION, MAINTENANCE AND INSTALLATION

INTRODUCTION

This manual will provide you with the information to properly install and maintain the electric panel to ensure a long service life. The Electric Panel is ruggedly constructed with NEMA switches and solid state components to give years of trouble free operation. The panel is installed near the ball, butterfly, or plug valve and wired to the pump control valve hydraulic panel and the main pump panel.

For proper operation of the pump control valve, the panel must be wired to the pump control panel. The panel model number and voltage are stamped on the nameplate for reference. This panel is not intended to control the pump start and stop sequence of the pump.

RECEIVING AND STORAGE

Inspect the panel upon receipt for damage in shipment. Unload the panel carefully to the ground without dropping. When lifting, the panel should be lifted with the door secured.

The panels should remain crated, clean and dry until installed to prevent weather related damage. For long-term storage greater than six months, the panels should be stored indoors or the ends of the pipes sealed to prevent weather related damage.

DESCRIPTION OF OPERATION

The electric panel is designed to work with the Val-Matic 5HP hydraulic panel in controlling and monitoring the operation of the pump control ball, butterfly, or plug valve.

The relays (3) and timer (4) are panel mounted and pre-wired to a terminal strip (5) in a hinged NEMA 4X enclosure for easy installation and to protect the equipment. The panel includes Run and Stop relays to control the operation of the pump. An adjustable timing relay monitors the operation of the system and automatically shuts down the pump if the pump does not build pressure or the valve fails to open.

Transformer-type Pilot Lights are used to provide safe indication. The RUN, OPEN, and CLOSE pilot lights indicate valve and pump operation. The STOP light indicates that an alarm condition exists and the pump is locked out. Once the alarm condition is resolved, the RESET button is pressed to reactivate the system.

An EMERGENCY STOP button is provided to stop the pump at the valve location. When the button is pressed, the valve closes at the normal rate, and automatically shuts off the pump when the valve closed limit switch is tripped.

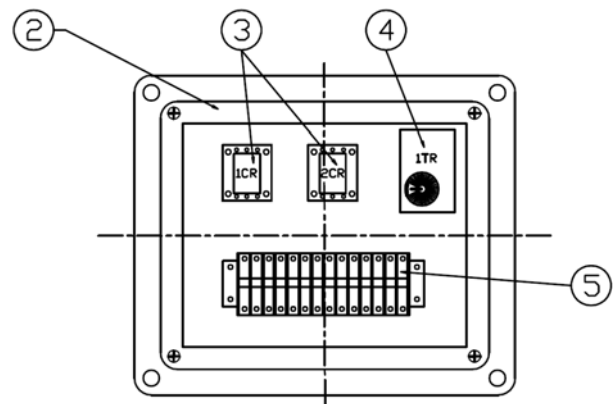
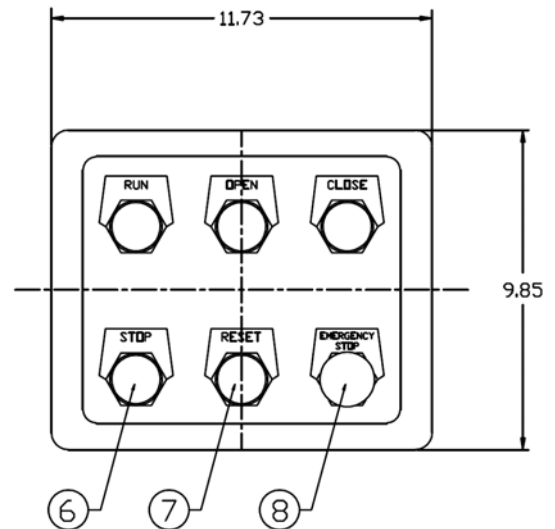

INSTALLATION

These instructions are provided to aid in the installation of this equipment. Val-Matic Valve cannot be responsible for improper installation.

WARNING

To reduce the risk of electric shock, serious injury or death when installing this equipment, follow these basic precautions:

- 1. Read all instructions before powering the panel.**
- 2. Observe all local codes and ordinances.**
- 3. Be sure to follow grounding instructions.**
- 4. Use a qualified electrician for making wiring connections.**

SELECTING THE LOCATION

The panel should be mounted near the control valve hydraulic controls or hydraulic panel. The panel can be mounted above or below the valve, but should be at a convenient elevation for easy access. Allow sufficient space for the door to swing fully open.

WIRING CONNECTIONS TO PANEL

The standard panel has twelve (12) terminal connections but special panels can have additional connections. Figure 2 shows a typical wiring method for the pump control system. There are many different configurations possible, but a common one is shown in Figure 2. Connect the ground terminal (G) to a suitable ground wire per local codes. Terminals (11) and (12) are optional and are used if a remote indication of an alarm is desired.

WIRING TO HYDRAULIC PANEL

Note that connections must be made to terminals (1), (5), and (7) of the hydraulic panel mounted near the control valve.

WIRING TO PUMP CONTROL VALVE

As shown in Figure 2, a closed limit switch (CLS) located on the pump control valve is needed to tell signal the pump circuit that the valve is closed and it is safe to shut down the pump. The wiring from the valve limit switch assembly is connected directly to this panel.

SEQUENCE OF OPERATION

GENERAL

The electrical panel is used with the hydraulic panel to control the opening and closing of the pump control valve and monitor the function of the pump control system. A safety circuit shuts down and locks out the pump when a loss of prime or pump/valve failure occurs. Refer to Figures 2 & 3.

PUMP START SEQUENCE:

The START button located in the Pump Motor Control Center is pressed, which energizes control relay 1CR. 1CR contact on line 5 energizes the pump motor relay PMSR and starts the pump. When the pump builds pressure, pressure switch PS1 closes and energizes the 4-Way solenoid valve 4SV, which opens the pump control valve.

PUMP STOP SEQUENCE:

The STOP button located in the PMCP is pressed, de-energizing 1CR and 4SV, which closes the valve. The pump continues to run until the closed limit switch contact, CLS on line 6 opens, de-energizing PMSR and stopping the pump.

EMERGENCY STOP:

In case of a local emergency, the EMER. STOP button on line 7 is pressed energizing control relay 2CR. 2CR contact on line 2 de-energizes 1CR and 4SV, which initiates the normal pump stop sequence. The red STOP light remains lit and the system locked closed until the RESET button is pressed. An alarm contact 2CR on line 13 is provided for a remote alarm light on the PMCP.

PUMP OR VALVE STOP:

When the start sequence is initiated, 1CR contact on line 10 energizes timing relay 1TR. If the pump fails to build pressure and activate PS1 or the ball valve fails to begin opening and trip CLS on line 10 within the set time period (5-10 min), then the timing relay contact 1TR on line 9 initiates the emergency stop sequence.

ELECTRICAL POWER FAILURE:

Upon loss of all power, the pump will stop. 4SV and the two 2-Way solenoid valves 2SV are de-energized, which closes the ball valve rapidly. If power is quickly restored, PMSR contact on line 6 prevents a pump restart.

VALVE INDICATION:

Closed limit switch contact CLS on line 11 de-energizes the red OPEN light when the valve is closed. Open limit switch contact OLS on line 12 de-energizes the green CLOSE light when the valve is open. In mid-travel, both lights are energized.

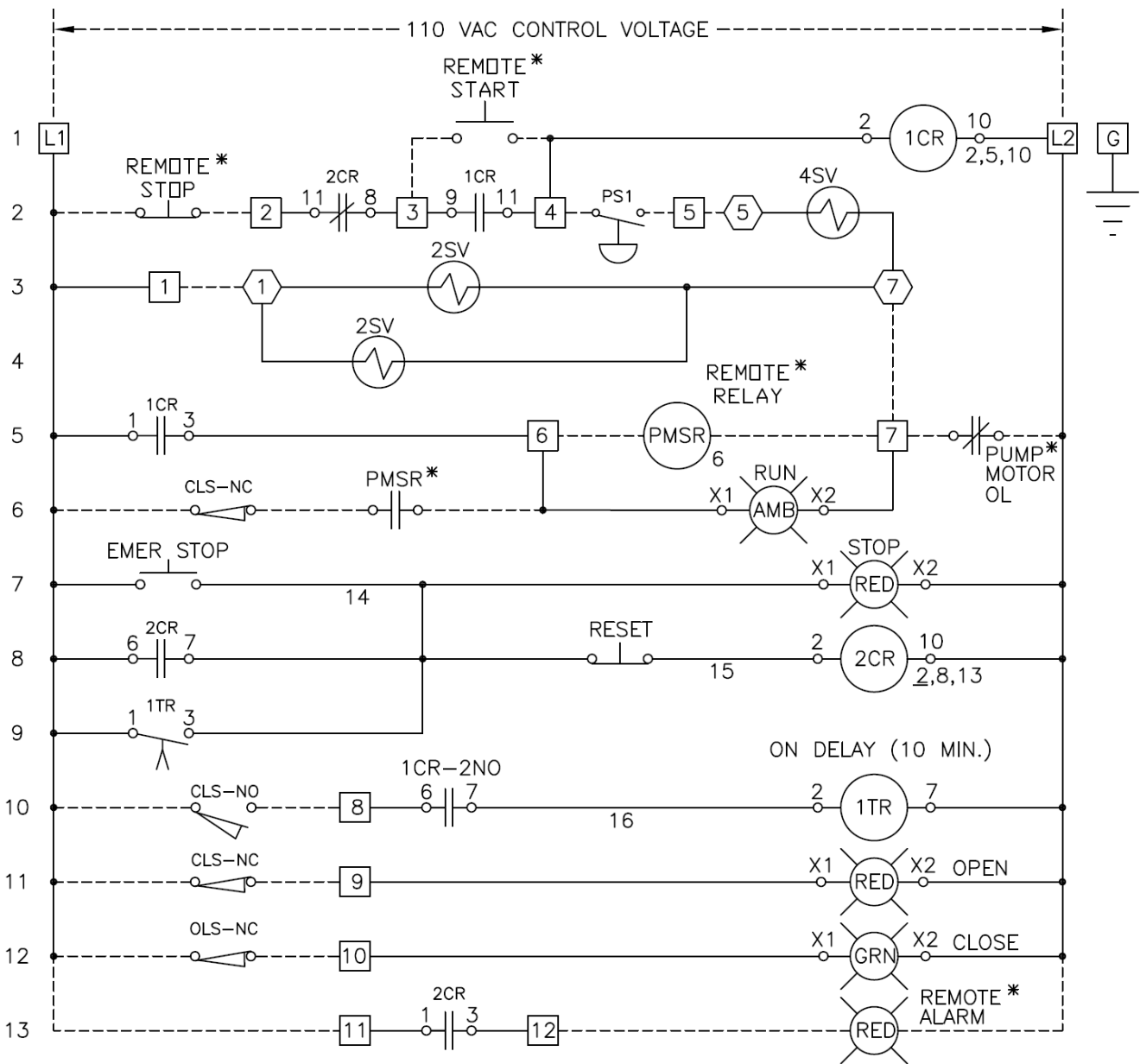

FOR SEQUENCE OF OPERATION, SEE DRAWING SS-2304

□ TERMINALS IN ELECTRIC PANEL, 5EP

⬡ TERMINALS IN HYDRAULIC PANEL, 5HP

--- FIELD WIRING

LIMIT SWITCHES SHOWN WITH VALVE IN MID-POSITION

* BY OTHERS

Revised 2-17-12

Figure 2. Typical Electrical Panel Wiring Diagram

MAINTENANCE

The electric panel should provide reliable operation of the pump control valve without maintenance.

LUBRICATION: The panel requires no lubrication or fluids for proper operation.

INSPECTION: Cleanliness of the panel is important. There should be no condensation in the enclosure. All external pilot devices should be level and rigid. Check that the door is closed and properly clamped shut.

<u>NO.</u>	<u>DESCRIPTION</u>	<u>MATERIAL</u>
1	Cabinet	Fiberglass
2	Panel	Fiberglass
3*	Control Relay	SQ-D 8501-KP13P14
4*	Control Timer	SQ-D 9050-JCK16
5	Terminal Strip	SQ-D 9080-GA6
6*	Pilot Light	SQ-D 9001-KP1
7	Push Button	SQ-D 9001-KR1
8	Push Button	SQ-D 9001-KR4

*Recommended Spare Part

TROUBLESHOOTING

Several problems and solutions are presented below to assist you in trouble shooting the electric panel in an efficient manner. The pipeline isolation valve should be closed during troubleshooting, to prevent reverse flow through the pump.

1. OPEN and CLOSED pilot lights do not light. Using a multimeter, check for power on limit switch on valve and back of light transformer. If power is present, replace bulb.
2. Control Valve fails to open or close.
 - a) Hydraulic panel may have failed. Refer to the 5HP instruction manual.
 - b) Press reset button.
 - c) Replace control relays.
3. STOP button will not go out when the RESET button is pressed.
 - a) Verify that control valve is closed and closed limit switch on line 10 of Figure 2 is open.
 - b) Replace timer if 1TR contact on line 9 will not open.

DISASSEMBLY

Before working on the panel, the pump control valve should be isolated and the pump locked out.

Refer to Figure 1 for part identification.

1. Remove electrical power from the cabinet terminal box. Test terminals with multimeter to verify lack of power.
2. Relays (3) and timers (4) can be easily removed by pulling them from their sockets.
3. Pilot devices in the door can be replaced by removing the lock nut on the outside of the door and pushing the device through the door.

The conduit can remain connected to the panel during servicing if desired.

REASSEMBLY

All parts must be clean and threaded surfaces should be clean. Worn or damaged parts, gaskets, and seals should be replaced during reassembly.

1. Insert the relays (3) and timer (4) into their respective sockets (see Figure 1).
2. Lights and pushbuttons are inserted into the holes in the doors and fastened in place with the locknut provided.
3. Wiring is reconnected in accordance with the wiring diagram in Figure 2 or in accordance with the wiring diagram furnished with the order.

PARTS AND SERVICE

Parts and service are available from your local representative or the factory. Make note of the Valve Size and Model Number located on the valve nameplate and contact:

Val-Matic Valve and Manufacturing Corp.
905 Riverside Drive
Elmhurst, IL 60126
Phone: (630) 941-7600
Fax: (630) 941-8042
www.valmatic.com

A sales representative will quote prices for parts or arrange for service as needed.

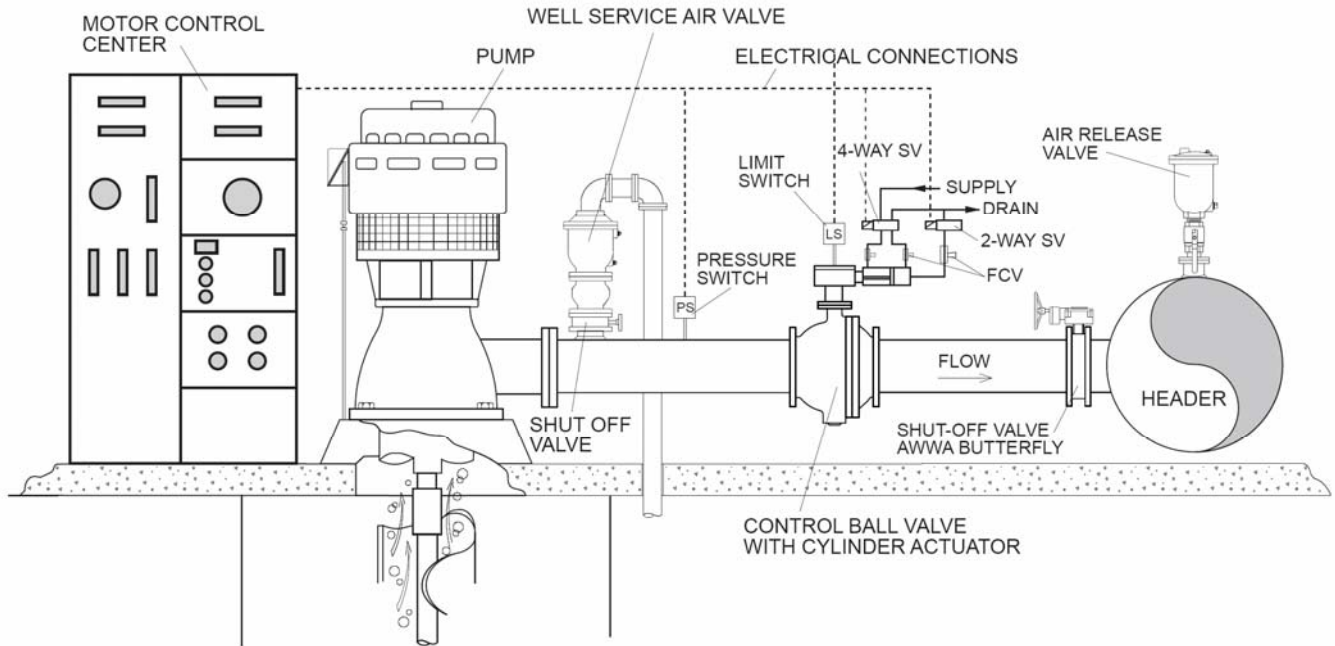

Figure 3. Typical Pump Control Valve Installation

LIMITED WARRANTY

All products are warranted to be free of defects in material and workmanship for a period of one year from the date of shipment, subject to the limitations below.

If the purchaser believes a product is defective, the purchaser shall: (a) Notify the manufacturer, state the alleged defect and request permission to return the product; (b) if permission is given, return the product with transportation prepaid. If the product is accepted for return and found to be defective, the manufacturer will, at his discretion, either repair or replace the product, f.o.b. factory, within 60 days of receipt, or refund the purchase price. Other than to repair, replace or refund as described above, purchaser agrees that manufacturer shall not be liable for any loss, costs, expenses or damages of any kind arising out of the product, its use, installation or replacement, labeling, instructions, information or technical data of any kind, description of product use, sample or model, warnings or lack of any of the foregoing. NO OTHER WARRANTIES, WRITTEN OR ORAL, EXPRESS OR IMPLIED, INCLUDING THE WARRANTIES OF FITNESS FOR A PARTICULAR PURPOSE AND MERCHANTABILITY, ARE MADE OR AUTHORIZED. NO AFFIRMATION OF FACT, PROMISE, DESCRIPTION OF PRODUCT OF USE OR SAMPLE OR MODEL SHALL CREATE ANY WARRANTY FROM MANUFACTURER, UNLESS SIGNED BY THE PRESIDENT OF THE MANUFACTURER. These products are not manufactured, sold or intended for personal, family or household purposes.