

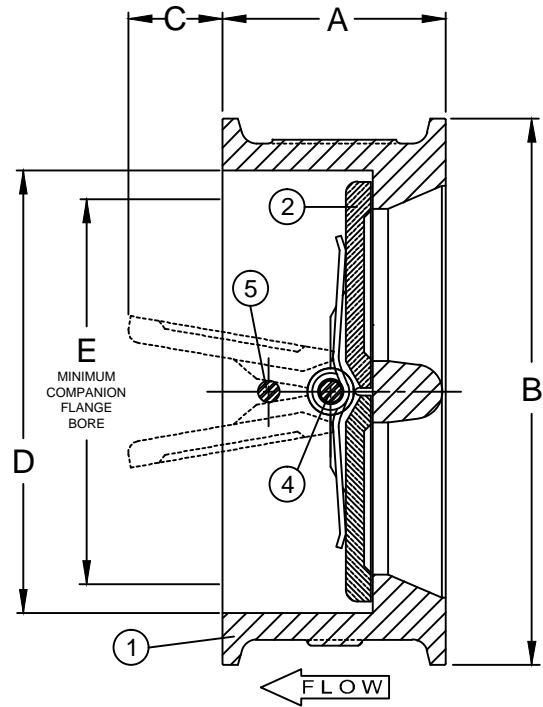

APPROVED  
SIZES 14 & 16 ONLY

ANSI CLASS 125 BOLT CIRCLE.

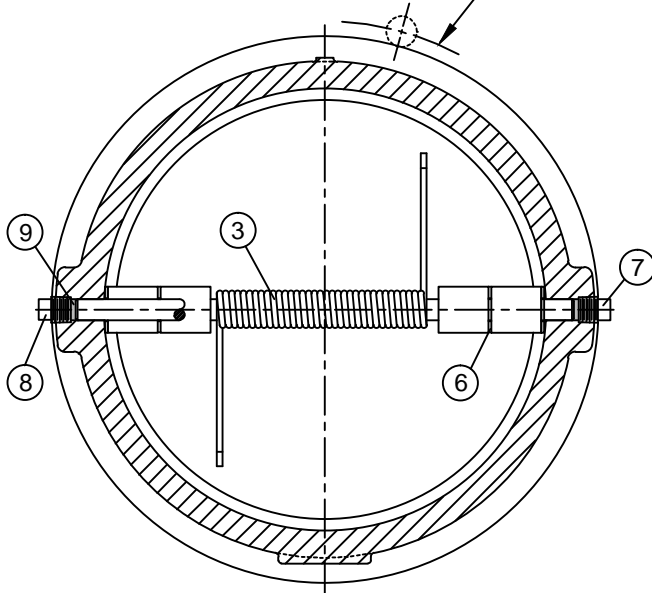

DRAWING DEPICTS 14" SIZE TO SCALE.

ANSI CLASS 125						
VALVE SIZE	MODEL NO.	A	B	C	D	E
14	8814	7.25	17.75	3.25	14.38	12.50
16	8816	7.50	20.25	4.50	16.38	15.00
18	8818	8.00	21.63	5.38	18.38	17.00
20	8820	8.38	23.88	6.38	20.25	19.00
24	8824	8.75	28.25	8.50	24.25	23.00
30	8830	12.00	34.75	9.50	30.00	28.50

ANSI PRESSURE -TEMPERATURE RATING	
TEMP. ° F.	MAXIMUM NON-SHOCK PRESSURE PSI
	CLASS 125 CAST IRON
150°	150
200°	115
250°	85
HYDROSTATIC TEST PRESSURE	230

VAL-MATIC® DUAL DISC® CHECK VALVES CAN BE USED FOR HORIZONTAL FLOW OR VERTICAL FLOW-UP APPLICATIONS ONLY.

CAUTION: FOR HORIZONTAL FLOW APPLICATIONS, VALVE MUST BE INSTALLED WITH THE DISC HINGE PIN IN THE VERTICAL POSITION.

SEE DRAWING NO. VM-8814-M FOR STANDARD MATERIALS OF CONSTRUCTION.

FOR 36" AND LARGER VALVES, SEE DRAWING NO. VM-8836.

FOR AIR SERVICE APPLICATIONS, SEE DRAWING NO. VM-8914.

ANSI CLASS 125 WAFER STYLE DUAL DISC® CHECK VALVE

DATE 11-12-09



VALVE AND MANUFACTURING CORP.

DRWG. NO.

VMC-8814