

VALVE SIZES 6"-36" ACTUATOR  
MOUNTING DETAIL

- QTY. 4, SIZES 6"-12" (STRADDLING  $\phi$ )
- QTY. 8, SIZES 14"-24" (ON  $\phi$ )
- QTY. 8, SIZES 30"-36" (STRADDLING  $\phi$ )

- Q THREAD SIZE
- R DEPTH OF TAPPED HOLES
- O BOLT CIRCLE DIAMETER

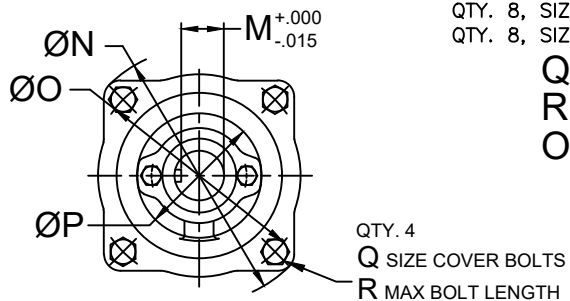

3"-4" ACTUATOR MOUNTING DETAIL  
(ACTUATOR BRACKET MOUNTS TO COVER USING PART #15 COVER BOLTS\*)  
\*LONGER BOLTS MAY BE REQUIRED DEPENDING ON ACTUATOR MOUNTING (SUPPLIED BY OTHERS)

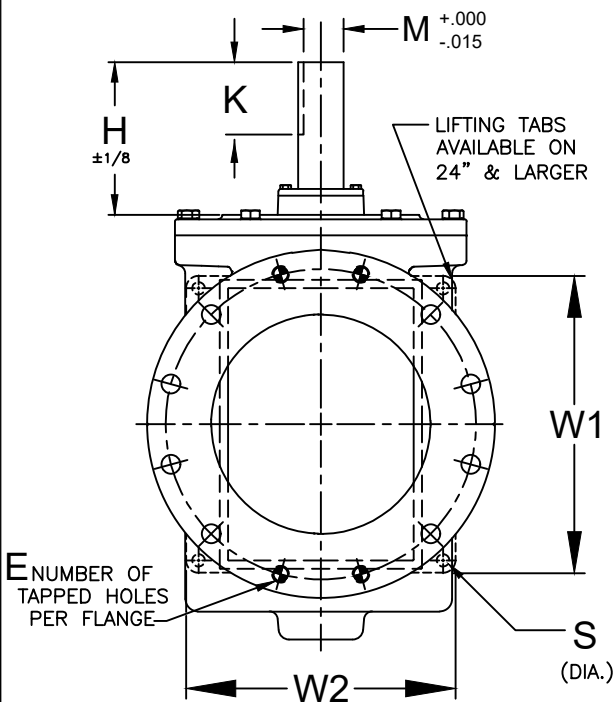
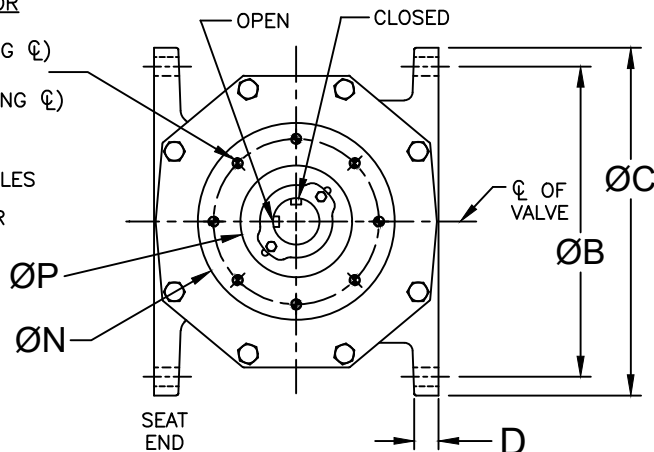

COLD WORKING PRESSURE  
175 PSI (3"-12")  
150 PSI (14"+)  
HYDRO TEST PRESSURE  
263 PSI (3"-12")  
225 PSI (14"+)

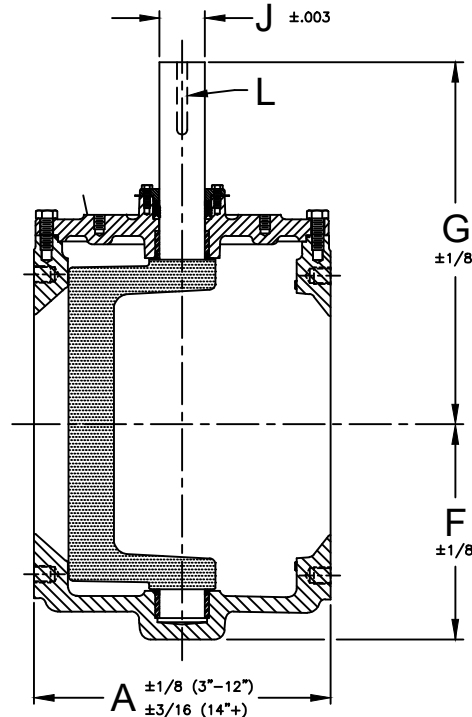

END FLANGE DRILLING CONFORMS TO ASME B16.1

REVISED 12-28-21

DIMENSIONS, INCHES

VALVE SIZE	C.W.P. (PSI)	A	B	C	D	E QTY.	E TAP	E DEEP	F	G	H	J	K	L	M	N	O	P	Q	R	S	W1	W2	BOLT SIZE	NO. OF BOLTS
3	175	8.00	6.00	7.50	0.75	2	5/8-11	0.75	4.47	9.54	5.89	1.246	2.50	1/4 SQ	1.112	7.38	6.18	3.50	1/2-13	1.05	-	-	-	5/8	4
4	175	9.00	7.50	9.00	0.94	0	--	--	5.63	11.0	6.31	1.496	2.50	3/8 SQ	1.289	7.71	6.50	3.75	1/2-13	1.12	-	-	-	5/8	8
6	175	10.50	9.50	11.00	1.00	4	3/4-10	1.25	7.06	12.4	5.04	1.496	2.13	3/8 SQ	1.289	7.75	6.50	5.50	1/2-13	1.00	-	-	-	3/4	8
8	175	11.50	11.75	13.50	1.13	4	3/4-10	1.38	8.75	14.0	5.32	1.496	2.13	3/8 SQ	1.289	7.75	6.50	5.50	1/2-13	1.00	-	-	-	3/4	8
10	175	13.00	14.25	16.00	1.19	8	7/8-9	1.38	10.4	18.1	7.88	2.120	3.94	1/2 SQ	1.845	9.38	8.00	6.38	1/2-13	0.81	-	-	-	7/8	12
12	175	14.00	17.00	19.00	1.25	8	7/8-9	1.38	13.0	19.3	6.93	2.120	2.56	1/2 SQ	1.845	9.50	8.00	6.75	1/2-13	0.81	-	-	-	7/8	12
14	150	17.00	18.75	21.00	1.38	8	1-8	1.00	13.0	21.9	9.12	2.743	4.06	5/8 SQ	2.402	11.9	10.0	6.75	5/8-11	0.88	-	-	-	1	12
16	150	17.75	21.25	23.50	1.44	8	1-8	1.00	15.7	23.6	9.13	2.743	4.06	5/8 SQ	2.402	11.9	10.0	6.75	5/8-11	0.88	-	-	-	1	16
18	150	21.50	22.75	25.00	1.56	8	1-1/8-7	1.13	15.7	24.3	9.19	3.120	4.00	3/4 SQ	2.704	11.9	10.0	6.75	5/8-11	0.88	-	-	-	1-1/8	16
20	150	23.50	25.00	27.50	1.69	12	1-1/8-7	1.13	17.4	25.9	9.07	3.745	4.13	7/8 SQ	3.261	12.0	10.0	7.38	5/8-11	1.13	-	-	-	1-1/8	20
24	150	30.00	29.50	32.00	1.88	12	1-1/4-7	1.38	18.8	29.9	10.8	4.495	5.50	1 SQ	3.944	14.5	12.75	9.25	3/4-10	1.25	1.25	28.25	28.25	1-1/4	20
30	150	37.50	36.00	38.75	2.12	20	1-1/4-7	1.88	24.0	36.4	13.9	4.995	8.37	1 1/4 SQ	4.296	18.0	15.0	10.5	1-1/4-7	1.75	1.25	29.25	33	1-1/4	28
36	150	52.00	42.75	46.00	2.38	32	1-1/2-6	2.25	27.0	41.5	14.6	5.995	7.75	1 1/2 SQ	5.155	30.0	18.0	-	1-1/4-7	1.75	1.75	35.25	40.5	1-1/2	32

3"-36" 100% PORT ASME CLASS 125 FLANGED CAM-CENTRIC® PLUG VALVE - BARESTEM

DATE 7/14/21

DRWG. NO.

VMC-5603F



VALVE AND MANUFACTURING CORP.