

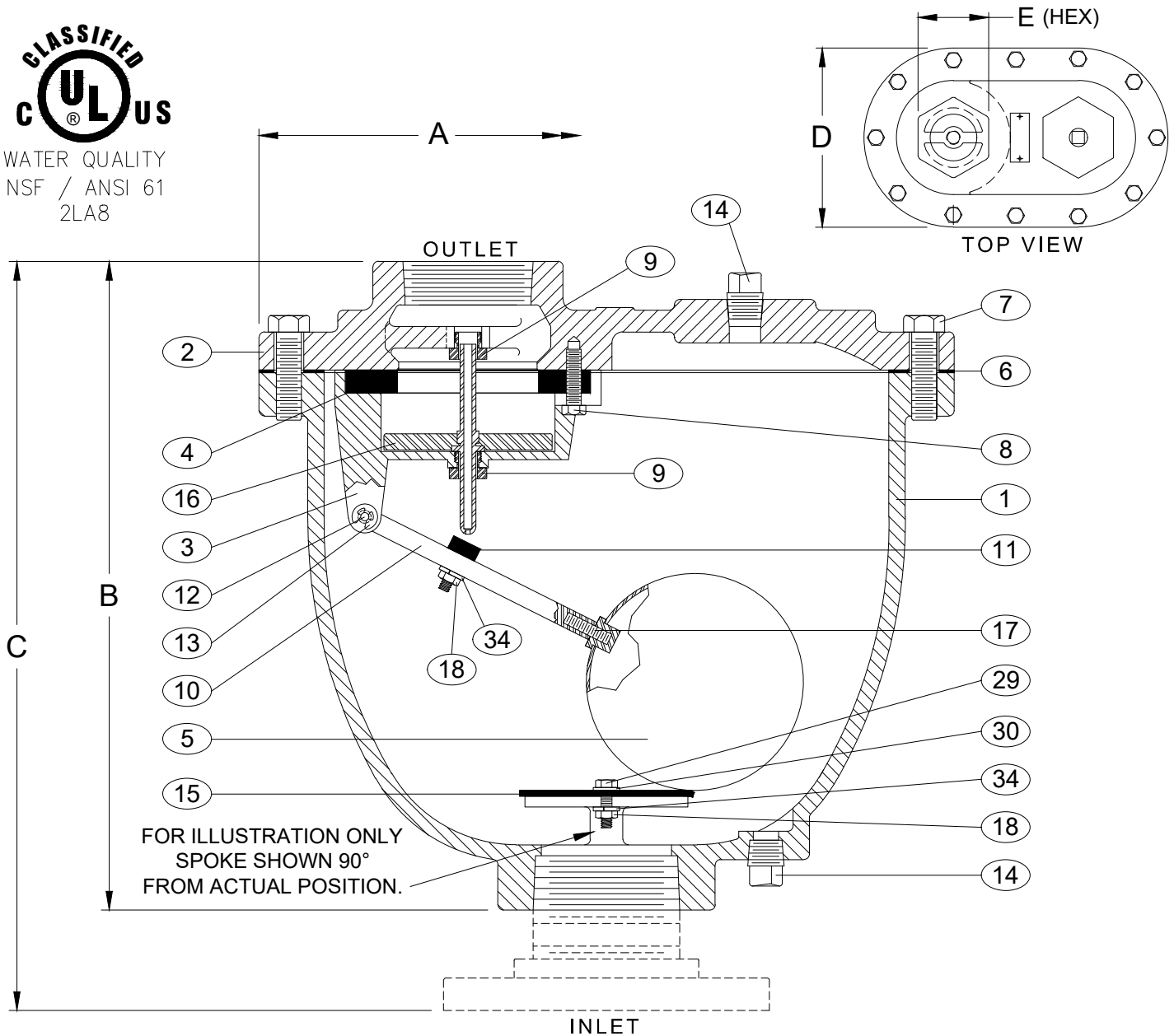

WATER QUALITY
NSF / ANSI 61
2LA8



FOR ILLUSTRATION ONLY
SPOKE SHOWN 90°
FROM ACTUAL POSITION.

SEE DRAWING NO. VM-201C-M FOR STANDARD MATERIALS OF CONSTRUCTION
SEE DRAWING NO. VM-201CDISV-M FOR SUPER VALVE MATERIALS OF CONSTRUCTION.

VALVE SIZE	MODEL NUMBER	A	B	C	D	E	INLET SIZE	OUTLET SIZE	ORIFICE SIZE	CWP PSI	* INLET FLANGE
3"	203C.2	16.00	15.00	—	9.63	4.38	3" NPT	3" NPT	3/32"	300	—
4"	204C.2	18.50	17.00	—	11.00	5.38	4" NPT	4" NPT	3/32"	300	—
3"	203C.14	16.00	—	16.75	9.63	4.38	3" 125 LB.	3" NPT	3/32"	150	SPK-003F
4"	204C.14	18.50	—	19.75	11.00	5.38	4" 125 LB.	4" NPT	3/32"	150	SPK-004F
3"	203C.15	16.00	—	17.25	9.63	4.38	3" 250 LB.	3" NPT	3/32"	300	SPK-203F
4"	204C.15	18.50	—	20.25	11.00	5.38	4" 250 LB.	4" NPT	3/32"	300	SPK-204F

* OPTIONAL INLET FLANGE SHIPPED LOOSE.

- | | | | |
|----------|--------------------|-------------------|---------------------|
| 1 BODY | 7 COVER BOLTS | 13 RETAINING RING | 29 CUSHION RETAINER |
| 2 COVER | 8 RETAINING SCREWS | 14 PIPE PLUG | 30 WASHER |
| 3 BAFFLE | 9 BUSHING | 15 CUSHION | 34 LOCK WASHER |
| 4 SEAT | 10 FLOAT ARM | 16 PLUG | |
| 5 FLOAT | 11 ORIFICE BUTTON | 17 FLOAT RETAINER | |
| 6 GASKET | 12 PIVOT PIN | 18 LOCK NUT | |

Revised 8-16-22 (Rev 3)

COMBINATION AIR VALVE (SINGLE BODY TYPE)

DATE 10-9-12

DRWG. NO.

VMC-203C



VALVE AND MANUFACTURING CORP.