

INTEGRAL SOIL PIPE ALIGNMENT/ MOTOR ATTACHMENT FLANGE. (MEETS MSS SP-101,FA10)

(4) HOLES J DIA. STRADDLING ϕ C BOLT CIRCLE.

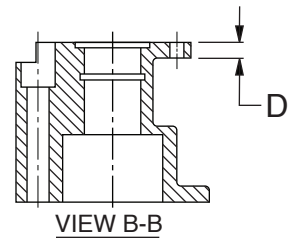

NOTES

1. THE DIRECTION OF OPENING MAY BE REVERSED, ONLY BY PROVIDING A BEVEL GEAR PER DRWG. NO. VM-LS5.2A (ON A SPECIAL ORDER BASIS)
2. ACTUATOR MEETS AWWA C504, LATEST REVISION.
3. SEE DRAWING NO. VM-LS5A-M FOR STANDARD MATERIALS OF CONSTRUCTION.

| DIMENSION, INCHES | | | | | | | | |
|-------------------|--------------|------|------|------|------|------|------|------|
| ACT. SIZE | NO. OF TURNS | C | D | E | F | G | H | J |
| LS-5A | 63 | 4.00 | 0.50 | 4.88 | 0.25 | 2.56 | 2.90 | 0.44 |

| DIMENSION, INCHES | | | | | | | | |
|-------------------|------|------|-------|-------|-------|------|-------|------|
| ACT. SIZE | K | L1 | L2 | M1 | M2 | N1 | N2 | P |
| LS-5A | 8.50 | 5.13 | 10.91 | 19.63 | 17.75 | 6.25 | 12.13 | 1.25 |

ABOVE GROUND SERVICE INDICATOR SHOWN. BURIED SERVICE NON-ROTATING COVER IS LARGER IN DIAMETER AND BOLTED TO THE HOUSING COVER INSTEAD OF THE LEVER.

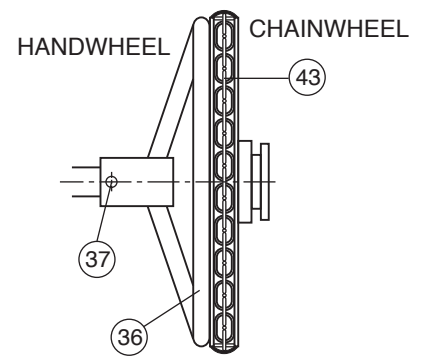
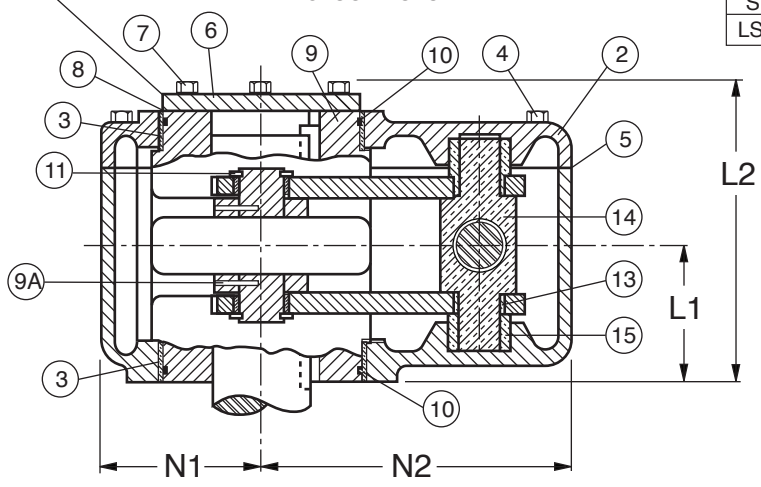

Revised 1-22-14

TRAVELING NUT ACTUATOR

DATE 8-22-08