

6" PIVOT PIN COVER DETAIL

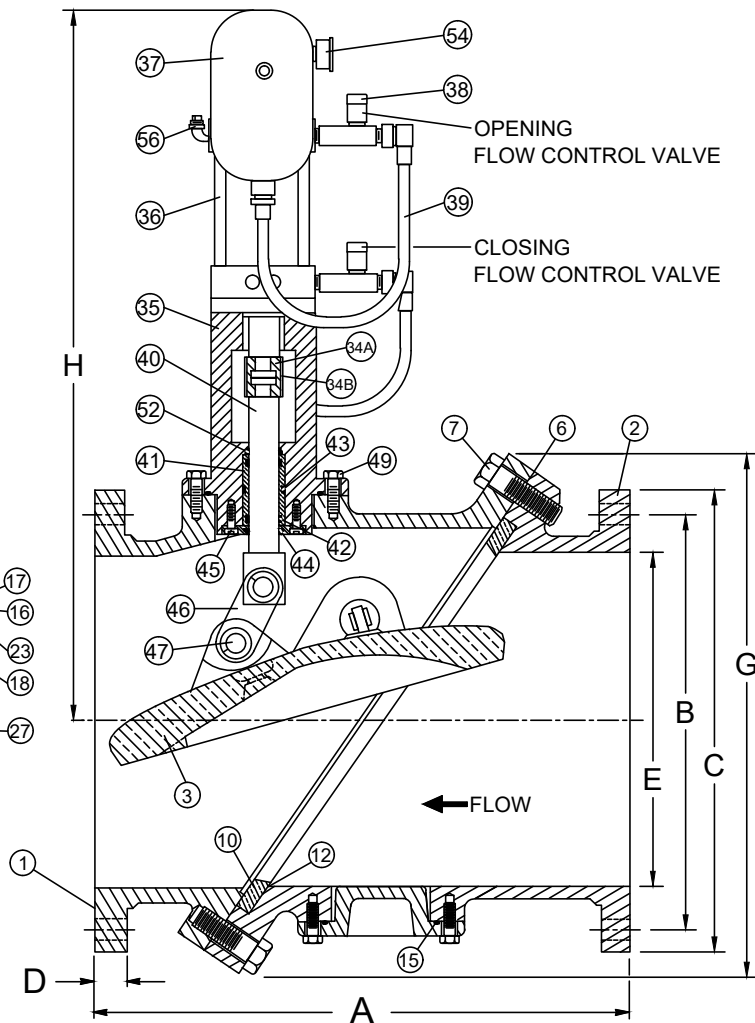

SEE DRAWING NO. VM-9806T-M FOR ANSI CLASS 125 MATERIALS OF CONSTRUCTION.

ANSI CLASS 125

VALVE SIZE	MODEL NO.	A	B	C	D	E	F	G	H	J	BOLT SIZE	NO. OF BOLTS
6	9806T	15	9 1/2	11	1	6	16	13	23	12	3/4	8
8	9808T	19 1/2	11 3/4	13 1/2	1 1/8	8	19	16	29	17	3/4	8
10	9810T	24 1/2	14 1/4	16	1 3/16	10	23	18	31	17	7/8	12

SEE DRAWING NO. VM-9706T-M FOR ANSI CLASS 250 MATERIALS OF CONSTRUCTION.

ANSI CLASS 250

VALVE SIZE	MODEL NO.	A	B	C	D	E	F	G	H	J	BOLT SIZE	NO. OF BOLTS
6	9706T	15	9 1/2	12 1/2	1 7/16	6	16	13	23	12	3/4	12
8	9708T	19 1/2	13	15	1 9/16	8	19	16	29	17	7/8	12
10	9710T	24 1/2	15 1/4	17 1/2	1 7/8	10	23	18	31	17	1	16

Revised 4-1-20

ANSI CLASS 125 AND CLASS 250 TILTED DISC® CHECK VALVE W/ TOP MOUNTED OIL DASHPOT

DATE 8-13-82



VALVE AND MANUFACTURING CORP.

DRWG. NO.

VM-9806T