

DISC POSITION INDICATOR

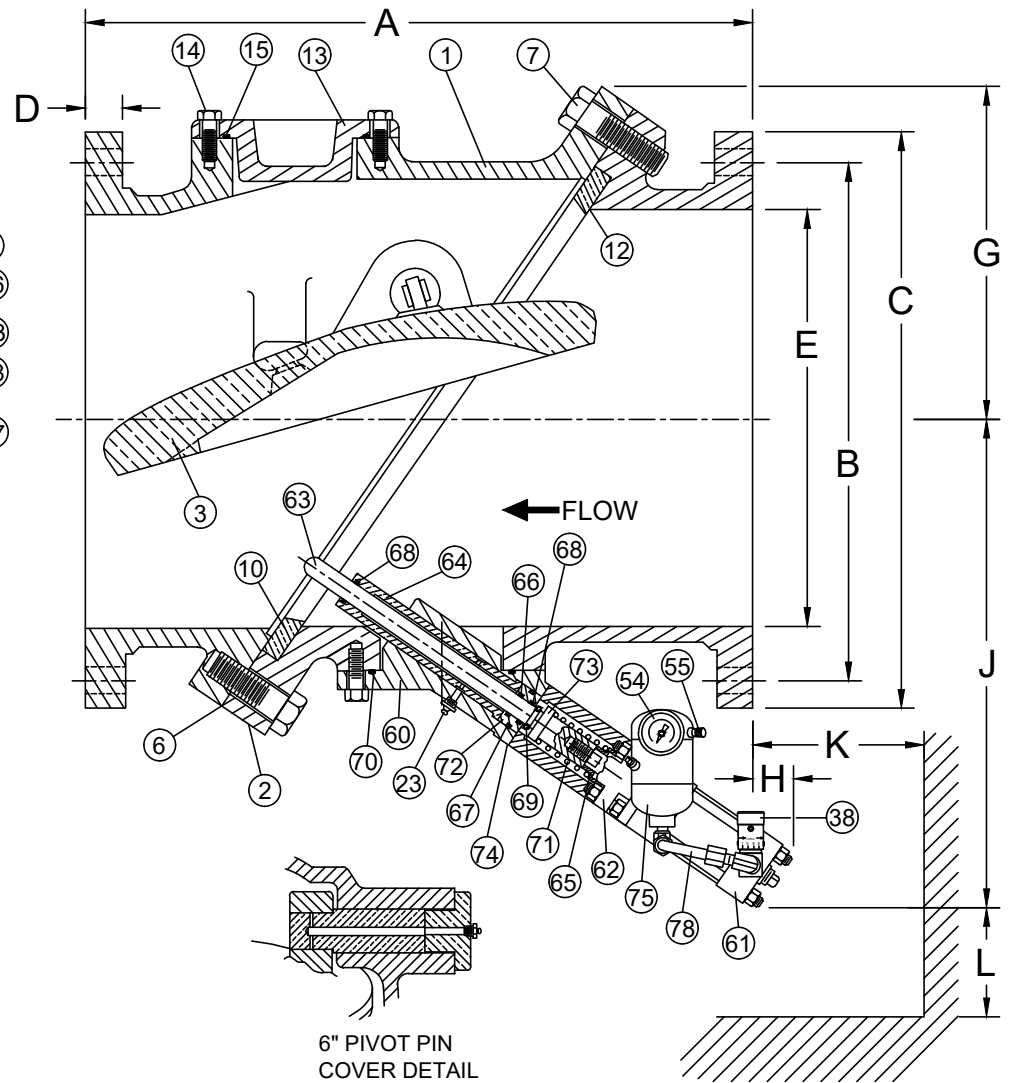

6" PIVOT PIN COVER DETAIL

SEE DRAWING NO. VM-9606B-M FOR ANSI CLASS 125 MATERIALS OF CONSTRUCTION.

ANSI CLASS 150														
VALVE SIZE	MODEL NO.	A	B	C	D	E	F	G	BOLT SIZE	NO. OF BOLTS	H	J	K	L
6	9606B	15	9 1/2	11	1	6	16	6 1/2	3/4	8	9	16	12	3
8	9608B	19 1/2	11 3/4	13 1/2	1 1/8	8	19	8	3/4	8	8	17	11	4
10	9610B	24 1/2	14 1/4	16	1 3/16	10	23	9 1/2	7/8	12	5	18	9	5

NOTES:

DIMENSIONS "K" AND "L" REPRESENT THE MINIMUM CLEARANCE REQUIRED TO REMOVE DASHPOT UNIT. HOWEVER DIMENSION "L" CAN REDUCED TO 1" IF SPACE REQUIREMENTS DICTATE.

FOR VERTICAL FLOW UP INSTALLATION, CONSULT FACTORY.

Revised 4-1-20

ANSI CLASS 150 TILTED DISC[®] CHECK VALVE WITH BOTTOM MOUNTED OIL DASHPOT

DATE 8-12-80

VAL-MATIC[®]

VALVE AND MANUFACTURING CORP.

DRWG. NO.

VM-9606B