

QTY. S SIZE Q x R
DEEP TAPPED HOLES.

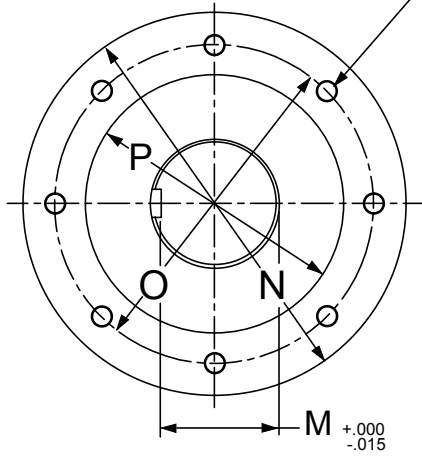

ACTUATOR MOUNTING DIMENSIONS
ON VALVE COVER

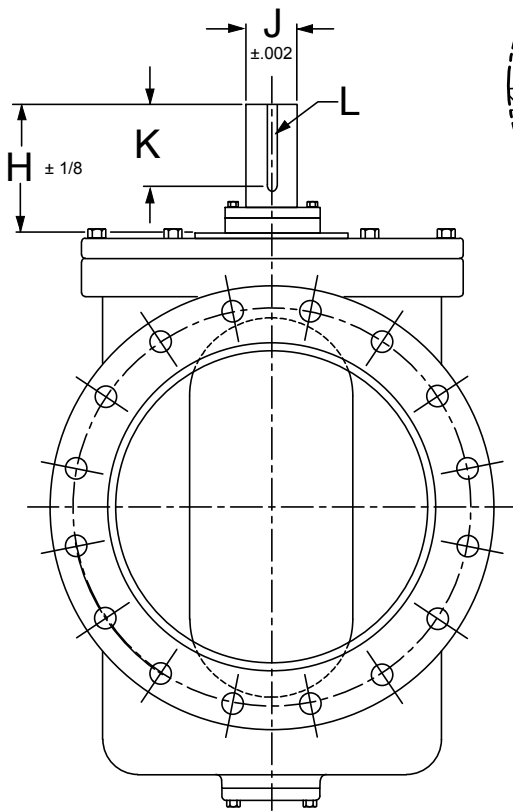
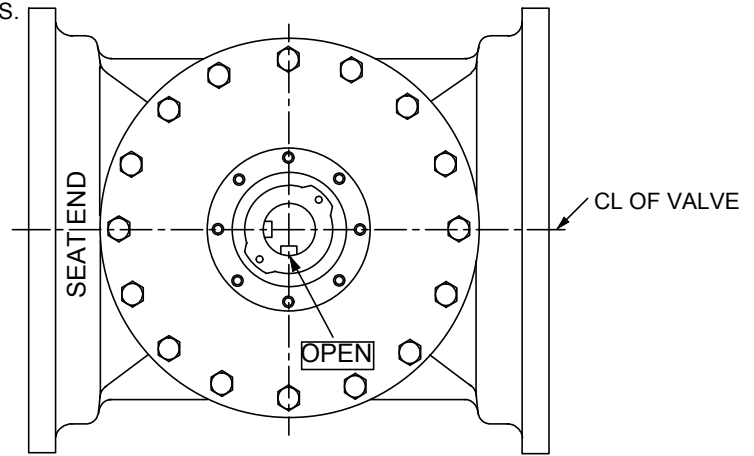

COLD WORKING PRESSURE
150 P.S.I.
HYDRO TEST PRESSURE
225 P.S.I.

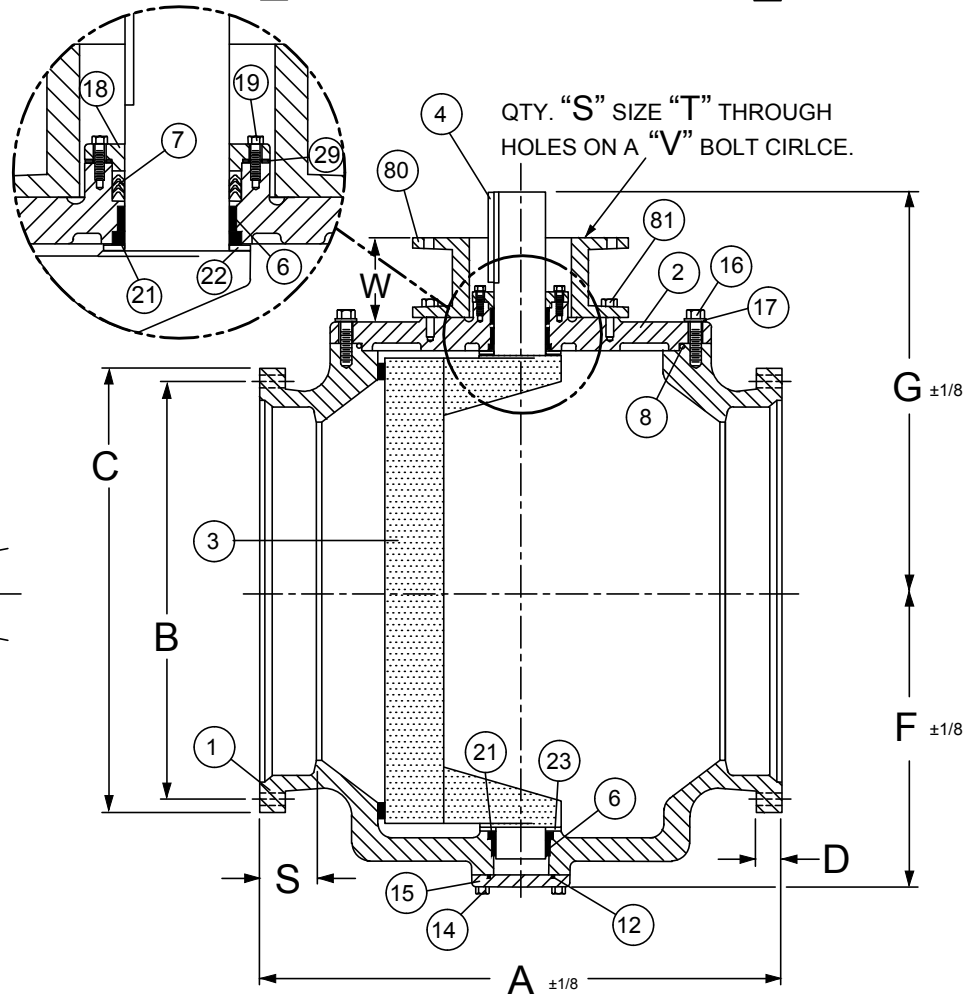

SEE DRAWING NO. VM-5842R-M FOR STANDARD MATERIALS OF CONSTRUCTION.

MECHANICAL JOINT ANSI/AWWA C111/A21.11

VALVE SIZE	A	B	C	D	F	G	H	J	K	L	M	N	O	P	Q	R	S	T	V	W	% OF STD. WT. PIPE
42	70.00	50.63	53.13	2.00	36.50	46.50	14.00	6.745	9.13	1 3/4" SQ.	5.760	17.25	15.00	11.50	1 1/4-7	1 1/4	8	1 3/8	16.00	6.75	75
48	84.00	57.50	60.00	2.00	38.50	51.70	16.02	8.000	8.75	2" SQ.	6.873	22.00	19.00	13.29	1 1/4-7	1 1/2	12	1 3/8	19.00	7.28	104

Revised 6-15-18

MECHANICAL JOINT CAM-CENTRIC® RECTANGULAR PLUG VALVE WITH BARE STEM

DATE 1-26-10



VALVE AND MANUFACTURING CORP.

DRWG. NO.

VM-5942R