

SEAT ADJUSTABLE FROM THIS SIDE.

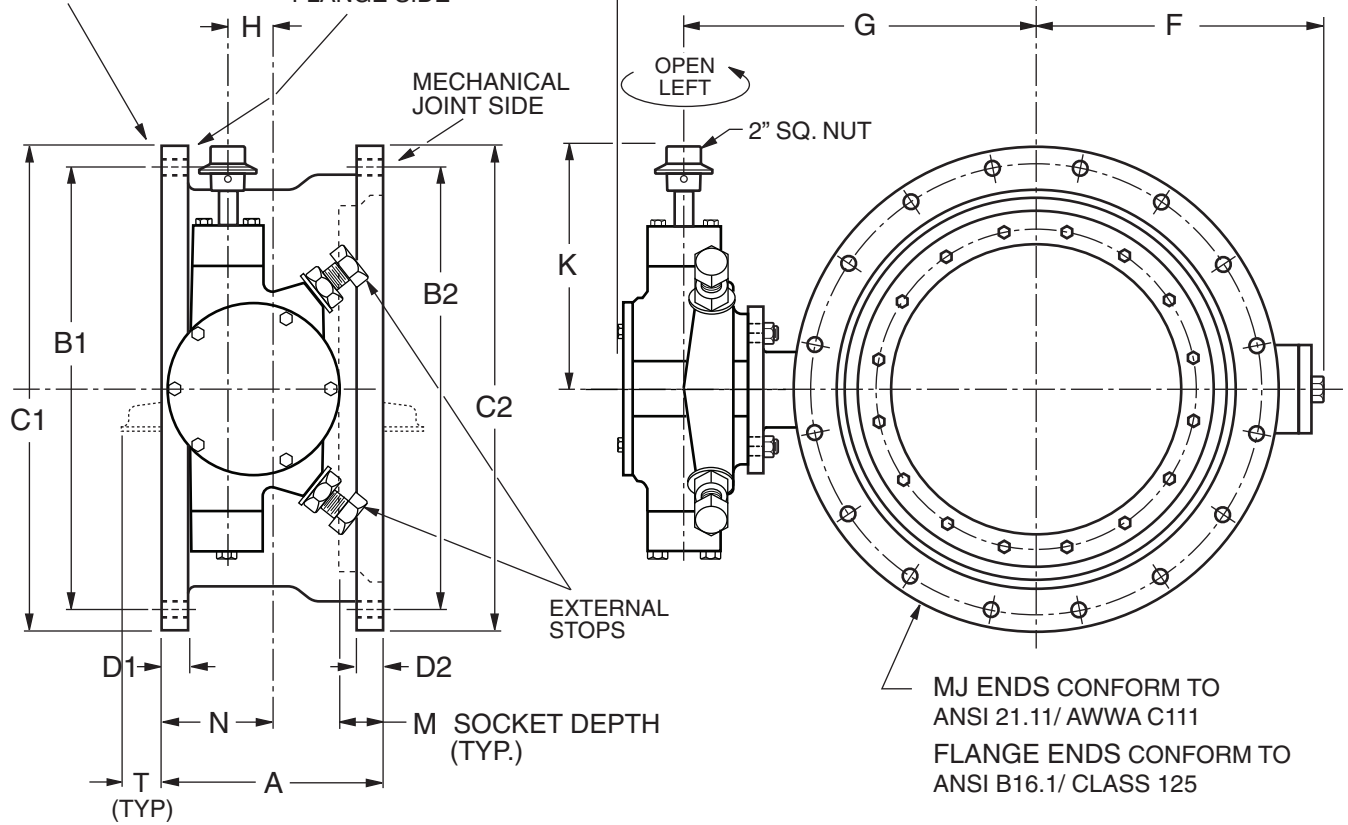

COLD WORKING PRESSURE 150 PSI (150B)

FLANGE X MECHANICAL JOINT DIMENSIONS, INCHES

VALVE SIZE	AWWA C504 CLASS	A	B1	B2	C1	C2	D1	D2	F	G	H	J	K	M	N	T	PD* Min.	TURNS TO OPEN	ACTUATOR SIZE	SHPG. WT. LBS.
6	150B	6.75	9.50	9.50	11.00	11.12	1.00	1.06	7.03	8.15	1.50	10.65	7.83	2.50	2.50	.69	4.63	15	LS-1.2A	110
8	150B	7.50	11.75	11.75	13.50	13.38	1.12	1.12	8.00	9.13	1.50	11.63	7.83	2.50	3.00	1.18	6.59	15	LS-1.2A	165
12	150B	8.62	17.00	16.25	19.00	17.94	1.25	1.25	11.06	12.56	2.00	15.25	8.71	2.50	4.00	2.13	10.66	20	LS-2A	300
16	150B	10.00	21.25	21.00	23.50	22.56	1.44	1.38	14.62	16.69	3.50	20.06	12.36	3.50	4.00	4.13	14.81	35	LS-3A	600

* MINIMUM PIPE I.D. TO CLEAR BUTTERFLY VALVE DISC (CHAMFER PIPE I.D. AT 45°) IF NECESSARY.

Revised 12-21-18

150B FLANGE X MECHANICAL JOINT BUTTERFLY VALVE WITH BURIED SERVICE ACTUATOR

DATE 3-14-11

VAL-MATIC VALVE AND MANUFACTURING CORP.

DRWG. NO. VM-2606/BLS