

TEST PRESSURE
1.5 TIMES COLD WORKING PRESSURE-C.W.P.

SERIES NO. 48A					
INLET SIZE		2"	3"	4"	
OUTLET SIZE		1/2"	1/2"	1/2"	
C O L D E S S O R K I N G	75 P.S.I.	MODEL NO.	48A.4	48A.5	48A.6
	C.W.P.	ORIFICE SIZE	5/16"	5/16"	5/16"
	150 P.S.I.	MODEL NO.	48A	48A.2	48A.3
	C.W.P.	ORIFICE SIZE	3/16"	3/16"	3/16"
	300 P.S.I.	MODEL NO.	48A.7	48A.8	48A.9
	C.W.P.	ORIFICE SIZE	5/32"	5/32"	5/32"

- | | | | | | |
|---|-----------------|----|----------------|----|--------------------|
| 1 | BODY | 10 | FLOAT ARM | 20 | EXTENSION SHAFT |
| 2 | COVER | 11 | ORIFICE BUTTON | 21 | LOCATING PIN |
| 3 | LEVERAGE FRAME | 12 | PIVOT PIN | 22 | ORIFICE BUTTON ARM |
| 4 | SEAT | 13 | RETAINING RING | 28 | PIPE PLUG |
| 5 | FLOAT | 14 | PIPE PLUG | 30 | WASHER |
| 6 | GASKET | 17 | FLOAT RETAINER | 33 | CLEVIS |
| 7 | COVER BOLT | 18 | LOCK NUT | 34 | LOCK WASHER |
| 8 | RETAINING SCREW | 19 | LINK | 35 | RETAINING SCREW |
| | | | | 36 | PIPE PLUG |

SEE DRAWING NO. VM-48A-M FOR STANDARD MATERIALS OF CONSTRUCTION.

Revised 10-11-02

WASTEWATER AIR RELEASE VALVE

DATE 3-15-00

VAL-MATIC[®] VALVE AND MANUFACTURING CORP.

DRWG. NO.

VM-48A

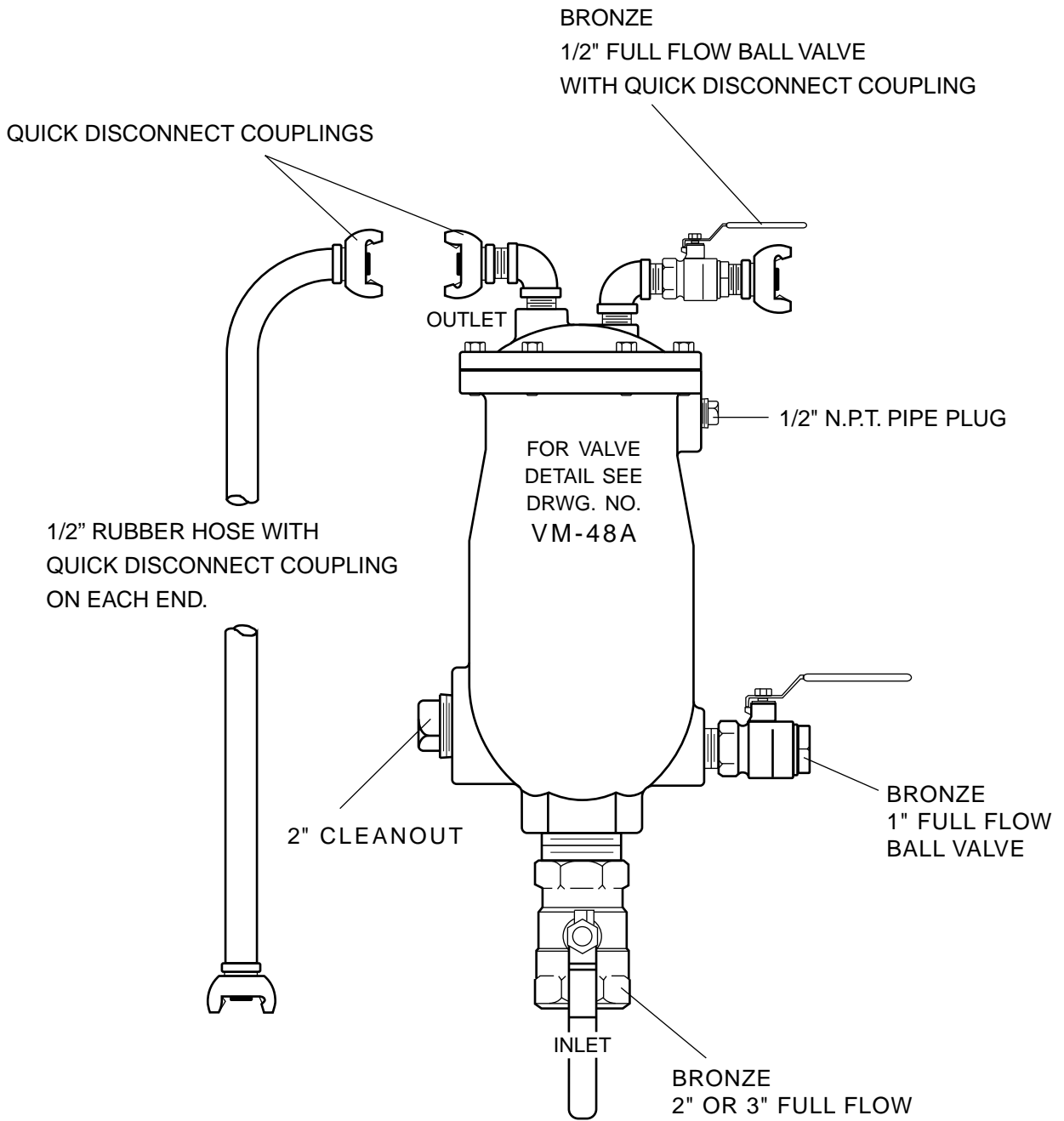

VALVE DIMENSIONS			
SIZE	2"	3"	4"
75 # MODEL	48A.4BW	48A.5BW	48A.6BW
150 # MODEL	48ABW	48A.2BW	48A.3BW
HEIGHT	23 ⁵ / ₁₆ "	26 ¹³ / ₁₆ "	33"
WIDTH	10 ¹ / ₂ "	10 ¹ / ₂ "	10 ¹ / ₂ "
DEPTH	7"	7"	7"
BWA KIT	SPK-48ABW	SPK-48A.2BW	SPK-48A.3BW

BACKWASH ACCESSORIES SHIPPED LOOSE.

Revised 8-5-03

WASTEWATER AIR RELEASE VALVE W/ BACKWASH ACCESSORY KIT

DATE 3-16-00

VAL-MATIC[®]

VALVE AND MANUFACTURING CORP.

DRWG. NO.

VM-48ABW

WASTEWATER AIR RELEASE VALVE

SERIES NO. 48A

STANDARD MATERIALS OF CONSTRUCTION

<u>PART NO.</u>	<u>PART NAME</u>	<u>MATERIAL</u>
1	BODY	CAST IRON ASTM A126, CLASS B
2	COVER	CAST IRON ASTM A126, CLASS B
3	LEVERAGE FRAME	STAINLESS STEEL T316, ASTM A240
4	SEAT	STAINLESS STEEL T316, ASTM A582
5	FLOAT	STAINLESS STEEL T316, ASTM A240
6	GASKET	COMPRESSED NON-ASBESTOS FIBER
7	COVER BOLT	ALLOY STEEL SAE, GRADE 5
8	RETAINING SCREW	STAINLESS STEEL T316, ASTM F879
10	FLOAT ARM	STAINLESS STEEL T316, ASTM A582
11	ORIFICE BUTTON	STAINLESS STEEL & BUNA-N
12	PIVOT PIN	STAINLESS STEEL T316, ASTM A276
13	RETAINING RING	STAINLESS STEEL PH 15-7 MO
14	PIPE PLUG	STEEL
17	FLOAT RETAINER	STAINLESS STEEL ASTM T316, F880
18	LOCK NUT	STAINLESS STEEL T316, ASTM F594
19	LINK	STAINLESS STEEL T316, ASTM A240
20	EXTENSION SHAFT	STAINLESS STEEL T316, ASTM A269
21	LOCATING PIN	STAINLESS STEEL T420
22	ORIFICE BUTTON ARM	STAINLESS STEEL T316, ASTM A582
23	SCREENED HOOD (OPTIONAL)	GALVANIZED IRON
28	PIPE PLUG	STEEL
30	WASHER	STAINLESS STEEL T316, ASTM A240
33	CLEVIS	STAINLESS STEEL T316, ASTM A240
34	LOCK WASHER	STAINLESS STEEL T316, ASTM A240
35	RETAINING SCREW	STAINLESS STEEL T316, ASTM F593
36	PIPE PLUG	STEEL

NOTE: ALL SPECIFICATIONS AS
LAST REVISED.

Revised 8-12-03

MATERIALS OF CONSTRUCTION

DATE 3/16/00

VAL-MATIC[®] VALVE AND MANUFACTURING CORP.

DRWG. NO.

VM-48A-M

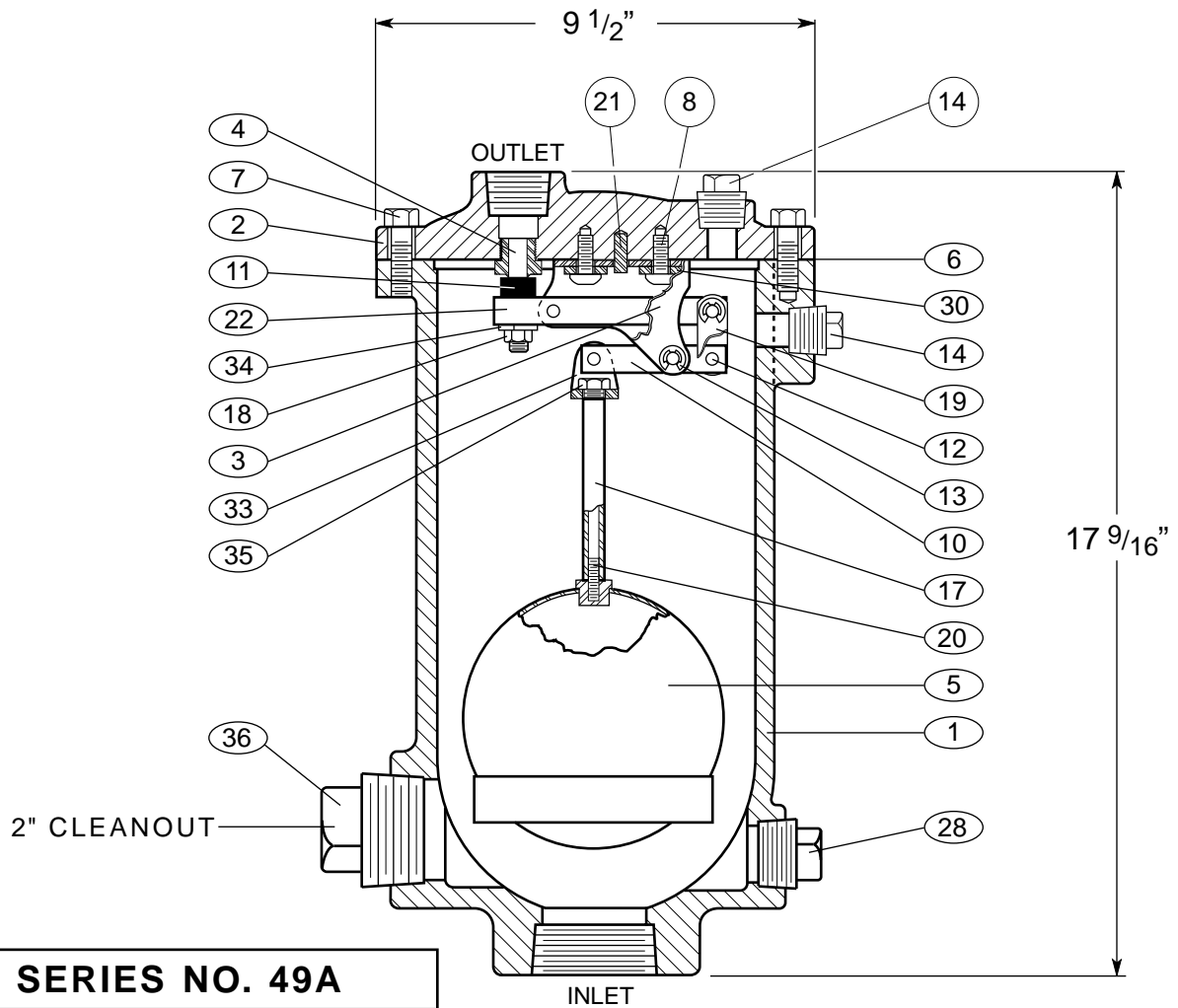

TEST PRESSURE
1.5 TIMES COLD WORKING PRESSURE-C.W.P.

SERIES NO. 49A						
INLET SIZE		2"	3"	4"		
OUTLET SIZE		1"	1"	1"		
C W P R E S S U R E W O R K I N G	75 P.S.I. C.W.P.	MODEL NO.	49A.4	49A.5	49A.6	
		ORIFICE SIZE	1/2"	1/2"	1/2"	
	150 P.S.I. C.W.P.	MODEL NO.	49A	49A.2	49A.3	
		ORIFICE SIZE	7/16"	7/16"	7/16"	
	300 P.S.I. C.W.P.	MODEL NO.	49A.7	49A.8	49A.9	
		ORIFICE SIZE	7/32"	7/32"	7/32"	

- | | | |
|-------------------|-------------------|-----------------------|
| 1 BODY | 10 FLOAT ARM | 20 EXTENSION SHAFT |
| 2 COVER | 11 ORIFICE BUTTON | 21 LOCATING PIN |
| 3 LEVERAGE FRAME | 12 PIVOT PIN | 22 ORIFICE BUTTON ARM |
| 4 SEAT | 13 RETAINING RING | 28 PIPE PLUG |
| 5 FLOAT | 14 PIPE PLUG | 30 WASHER |
| 6 GASKET | 17 FLOAT RETAINER | 33 CLEVIS |
| 7 COVER BOLT | 18 LOCK NUT | 34 LOCK WASHER |
| 8 RETAINING SCREW | 19 LINK | 35 RETAINING SCREW |
| | | 36 PIPE PLUG |

SEE DRAWING NO. VM-49A-M FOR STANDARD MATERIALS OF CONSTRUCTION.

Revised 8-5-03

WASTEWATER AIR RELEASE VALVE

DATE 3-20-00

VAL-MATIC[®]

VALVE AND MANUFACTURING CORP.

DRWG. NO.

VM-49A

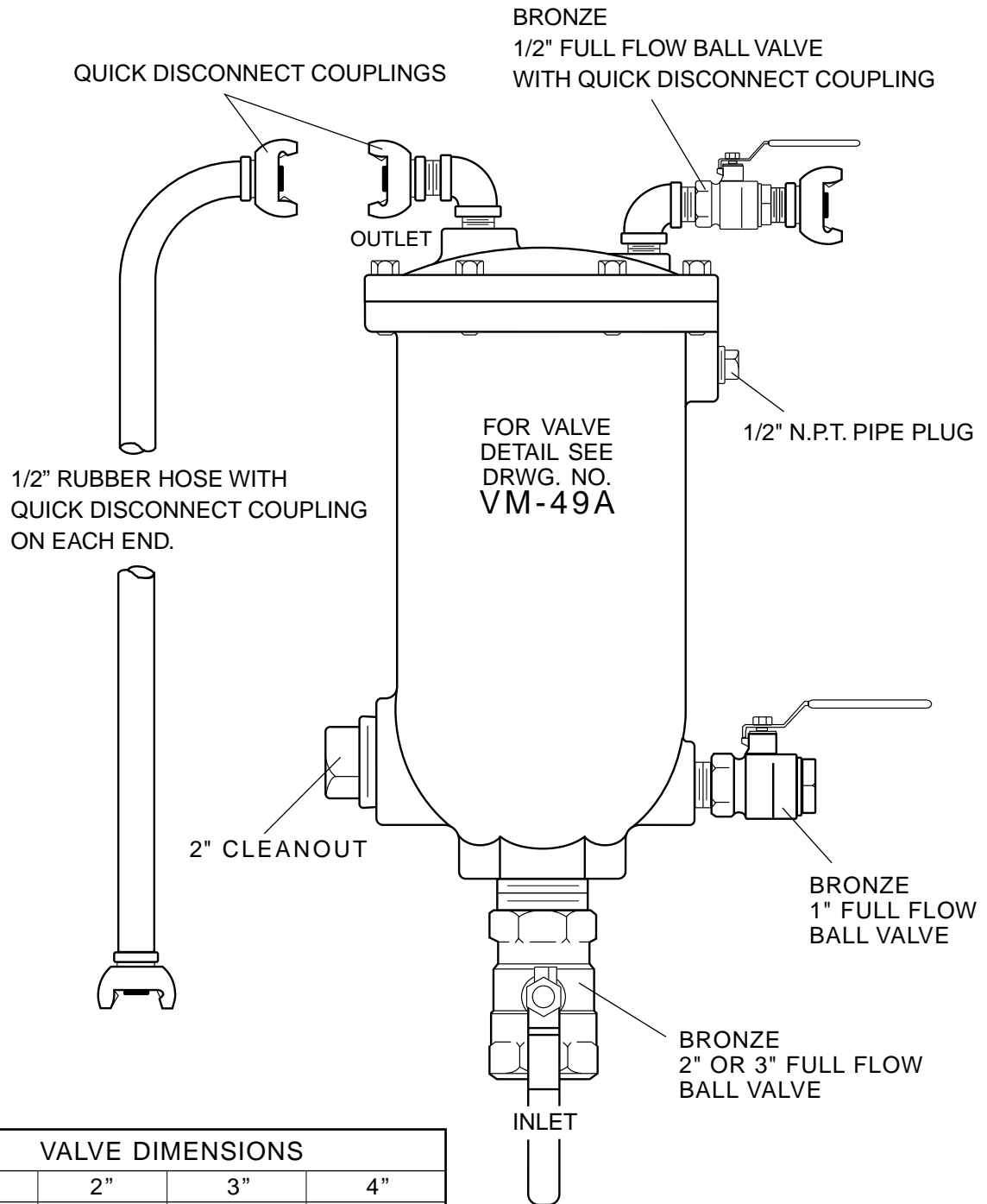

VALVE DIMENSIONS			
SIZE	2"	3"	4"
75 # MODEL	49A.4BW	49A.5BW	49A.6BW
150 # MODEL	49ABW	49A.2BW	49A.3BW
HEIGHT	26 1/16"	29 9/16"	35 3/4"
WIDTH	14"	14"	14"
DEPTH	9 1/2"	9 1/2"	9 1/2"
BWA KIT	SPK-48ABW	SPK-48A.2BW	SPK-48A.3BW

BACKWASH ACCESSORIES SHIPPED LOOSE.

Revised 8-5-03

WASTEWATER AIR RELEASE VALVE W/ BACKWASH ACCESSORIES KIT

DATE 3-22-00

VAL-MATIC[®]

VALVE AND MANUFACTURING CORP.

DRWG. NO.

VM-49ABW

WASTEWATER AIR RELEASE VALVE

SERIES NO. 49A

STANDARD MATERIALS OF CONSTRUCTION

<u>PART NO.</u>	<u>PART NAME</u>	<u>MATERIAL</u>
1	BODY	CAST IRON ASTM A126, CLASS B
2	COVER	CAST IRON ASTM A126, CLASS B
3	LEVERAGE FRAME	STAINLESS STEEL T316, ASTM A240
4	SEAT	STAINLESS STEEL T316, ASTM A276
5	FLOAT	STAINLESS STEEL T316, ASTM A240
6	GASKET	COMPRESSED NON-ASBESTOS FIBER
7	COVER BOLT	ALLOY STEEL SAE, GRADE 5
8	RETAINING SCREW	STAINLESS STEEL T316, ASTM F879
10	FLOAT ARM	STAINLESS STEEL T316, ASTM A276
11	ORIFICE BUTTON	STAINLESS STEEL & BUNA-N
12	PIVOT PIN	STAINLESS STEEL T316, ASTM A276
13	RETAINING RING	STAINLESS STEEL PH 15-7 MO
14	PIPE PLUG	STEEL
17	FLOAT RETAINER	STAINLESS STEEL T316, ASTM A276
18	LOCK NUT	STAINLESS STEEL T316, ASTM F594
19	LINK	STAINLESS STEEL T316, ASTM A240
20	EXTENSION SHAFT	STAINLESS STEEL T316, ASTM A269
21	LOCATING PIN	STAINLESS STEEL T420
22	ORIFICE BUTTON ARM	STAINLESS STEEL T316, ASTM A276
28	PIPE PLUG	STEEL
30	WASHER	STAINLESS STEEL T316, ASTM A240
33	CLEVIS	STAINLESS STEEL T316, ASTM A240
34	LOCK WASHER	STAINLESS STEEL T316, ASTM A240
35	RETAINING SCREW	STAINLESS STEEL T316, ASTM F593
36	PIPE PLUG	STEEL

NOTE: ALL SPECIFICATIONS AS
LAST REVISED.

Revised 12-9-03

MATERIALS OF CONSTRUCTION

DATE 3/21/00

VAL-MATIC[®] VALVE AND MANUFACTURING CORP.

DRWG. NO.

VM-49A-M