

SILENT CHECK VALVE INSTALLATION REQUIREMENTS

DAMAGE TO THE VALVE AND / OR INTERNAL LEAKAGE MAY RESULT IF PIPE FLANGES OTHER THAN THOSE WITH STANDARD FLAT FACES, CONFORMING TO ANSI B16.5 OR AWWA C207 ARE USED.

WARNING NOTICE: FLANGES HAVING AN EXPANDED INSIDE DIAMETER (OFTEN FOUND ON MORTAR LINED PIPE) CANNOT BE USED ON THE INLET SIDE OF THE VALVE. A RING FLANGE HAVING A MAXIMUM INSIDE DIAMETER, AS SHOWN IN "A" DIMENSION BELOW, MUST BE INSERTED BETWEEN THE VALVE AND MORTAR LINED PIPE FLANGE.

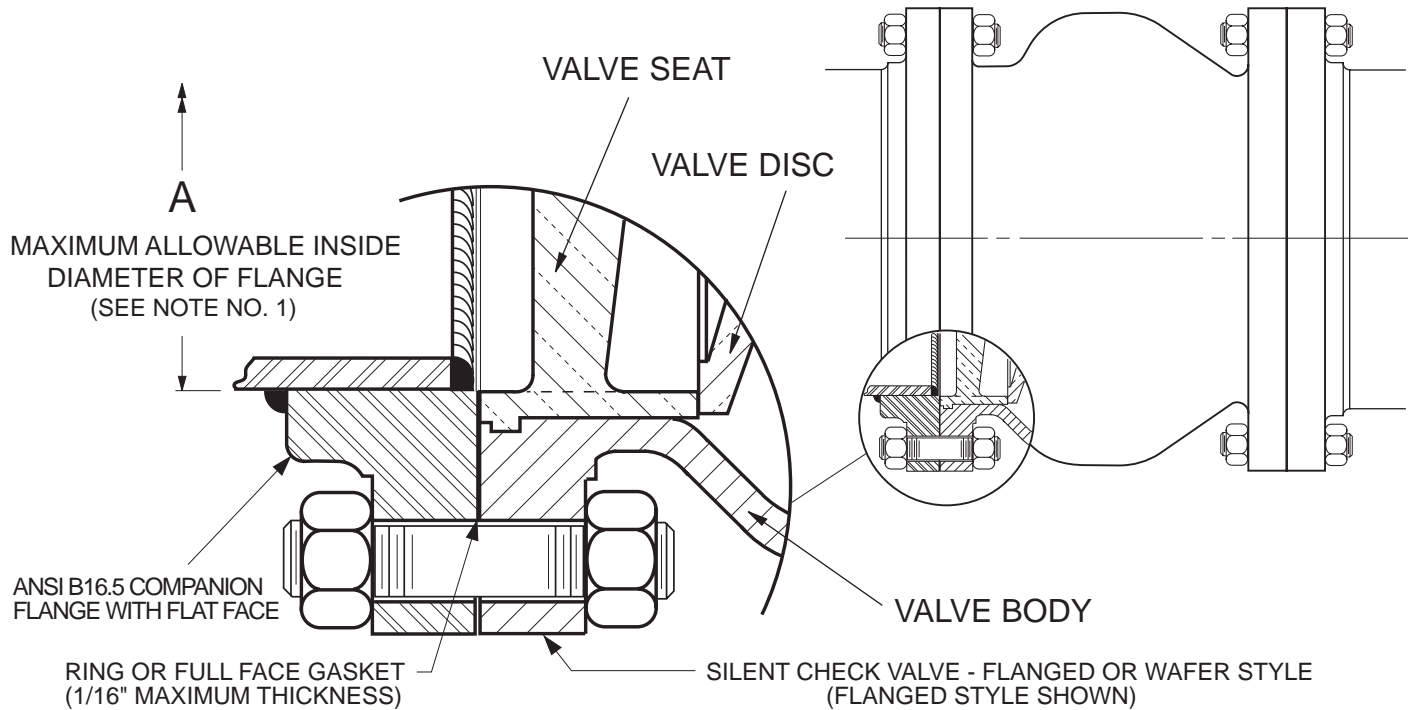

NOTE NO. 1 - THE MATING COMPANION FLANGE I.D. MUST OVERLAP THE VALVE SEAT. THIS IS REQUIRED TO PROVIDE PROPER SEAT RETENTION.

NOTE NO. 2 - THE FLANGE GASKET MUST BE PROPERLY CENTERED AND OF THE SIZE INDICATED. THIS IS REQUIRED TO ACHIEVE A SEAL BETWEEN THE SEAT O.D. AND THE BODY I.D. INTERFACE AREA.

MAXIMUM ALLOWABLE INSIDE DIAMETER OF FLANGE (SEE NOTE NO. 1)			
VALVE SIZE	A	VALVE SIZE	A
2 1/2	2.940	14	14.140
3	3.570	16	16.160
4	4.570	18	18.180
5	5.660	20	20.200
6	6.720	24	24.250
8	8.720	30	30.250
10	10.880	36	36.250
12	12.880	42	42.250

STANDARD RING GASKET DIMENSIONS (SEE NOTE NO. 2)							
VALVE SIZE	I.D. FOR 125 LB. AND 250 LB. GASKET	O.D. FOR 125 LB. GASKET	O.D. FOR 250 LB. GASKET	VALVE SIZE	I.D. FOR 125 LB. AND 250 LB. GASKET	O.D. FOR 125 LB. GASKET	O.D. FOR 250 LB. GASKET
2 1/2	2.875	4.875	5.125	14	14.000	17.750	19.125
3	3.500	5.375	5.875	16	16.000	20.250	21.250
4	4.500	6.875	7.125	18	18.000	21.625	23.500
5	5.562	7.750	8.500	20	20.000	23.875	25.750
6	6.625	8.750	9.875	24	24.000	28.250	30.500
8	8.625	11.000	12.125	30	30.000	34.750	37.500
10	10.750	13.375	14.250	36	36.000	41.250	44.000
12	12.750	16.125	16.625	42	42.000	48.000	50.750

Revised 5-12-98

SILENT CHECK VALVE FLANGE INSTALLATION REQUIREMENTS

DATE 4-7-96

VAL-MATIC®

VALVE AND MANUFACTURING CORP.

DRWG. NO.

SS-974