

**Val-Matic® Cam-Centric®
Rectangular Ported, Eccentric Plug Valves
Seating System**

The success of the seating systems of an eccentric plug valve is predicated on three factors; the movement of the plug in and out of the seat, positioning of the plug in the seat and the resilient/welded mating surfaces.

Movement of the plug

The movement of the plug in and out of the seat is referred to as eccentric which means off-center. The valve's seat is off-set from the center line of the pivot axis. This off-set provides an eccentric action allowing the plug to rotate in and out of the seated position with minimal rubbing or wear.

Positioning the Plug

To assure a good seal, proper positioning of the plug in the seat must be assured. The Val-Matic® design relies on two factors to accomplish this. Closed positioning is assured by adjustable stops located on the cover for lever actuated valves and on the gear for gear actuated valves. Vertical positioning is provided by thrust bearings located above and below the plug.

Finally, to assure proper position as well as a leak free performance every valve is 100% tested and inspected prior to shipment.

Mating Surfaces

The mating surfaces of the Cam-Centric® Plug Valve are resilient to metal.

The standard resilient surface is a Buna-N facing. The Buna-N formulation was specially developed by Val-Matic® and leading industry rubber experts to assure that the plug would seal time and time again without loosing its original shape and provide maximum abrasion resistance while handling the wide variety of contaminants found in wastewater. Small diameter valves have precision molded plugs to assure an optimum seating surface. Larger sizes which do not lend themselves to molding, are vulcanized and ground to assure a high quality finish. Both provide a smooth surface for excellent seating as well as low torque during movement in and out of the seat.

The valve seat is a welded overlay of 99% pure nickel applied directly to the body on a pre-machined surface and precision machined to a smooth finish.

There are several factors which will impact the quality of a weld. One is the quality of materials. Val-Matic® requires material certifications for both the body casting and the nickel welding wire to assure high quality and consistency. The second factor is the surface. If the surface is not properly prepared the weld will be inconsistent. It is for this reason that the surface is machined prior to welding. The third factor which must be considered is the welding process itself. The temperature and the way the weld is applied are both critical when trying to achieve a high quality weld. A state-of-the-art robotic welding system is utilized which assures that each and every weld will be applied in a consistent manner. The robotic system was developed specifically for Plug Valves. The system took over three years to develop and included the welding of hundreds of test bodies. Upon Completion of development of the prototype, the production system was built, tested and installed at Val-Matic®.

The seating system has successfully completed all of the pressure and cycle proof of design tests in accordance with AWWA C504 and MSS-SP-108.

Revised 4-13-98

Seating System of Cam-Centric® Rectangular Ported, Eccentric Plug Valves

DATE 10-6-94

VAL-MATIC® VALVE AND MANUFACTURING CORP.

DRWG. NO.
SS-1124

CAM-CENTRIC[®] PLUG VALVE ECCENTRIC ACTION

The Cam-Centric[®] Plug Valve is an eccentric acting valve. The seat is eccentrically located from the center line of the valve's shaft. This provides an eccentric action allowing the plug to rotate in and out of the seated position without rubbing or scraping, thereby preventing high torque and wear to the valve seat and plug. The valve is designed to control flow and shut off in both the direct and reverse directions.

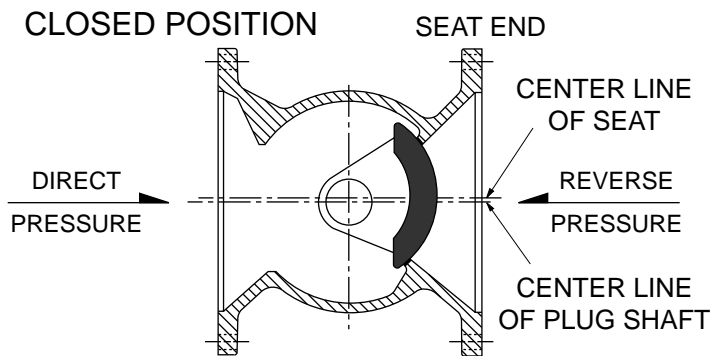

The eccentric action forces the resilient faced plug firmly against the seat, assuring a positive valve shut-off. An adjustable limit stop on the actuator allows the plug to be turned further into the seat, providing extended service life.

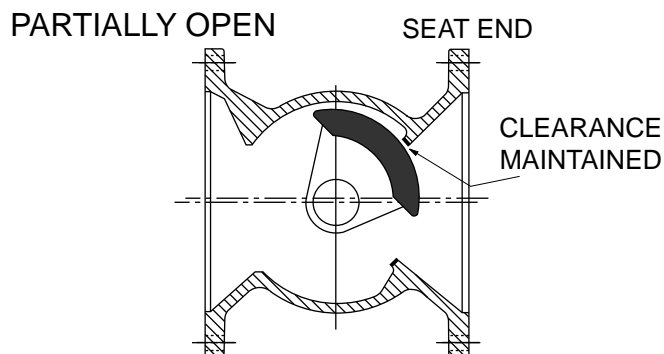

The eccentric action pulls the plug away from the seat as it rotates open. This action provides clearance between the plug and seat preventing wear and scuffing of the plug. Throttling characteristics can be achieved in partially open positions.

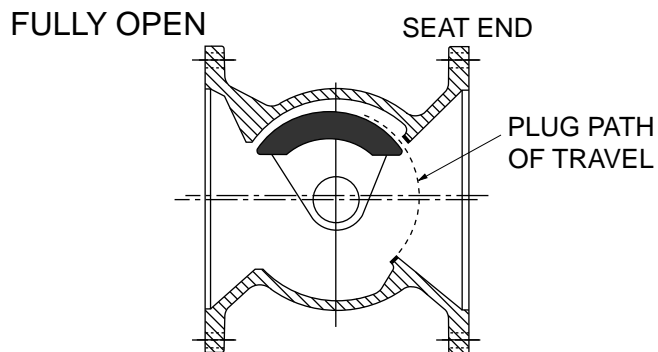

With the eccentric plug rotated to the fully open position, clearance is maintained at all points around the plug. In this position, maximum flow is achieved through the full rectangular port and unrestricted flow way.

Revised 2-20-02

CAM-CENTRIC[®] PLUG VALVE ECCENTRIC ACTION

DATE 11-10-87

VAL-MATIC[®] VALVE AND MANUFACTURING CORP.

DRWG. NO.

SS-606

**CAM-CENTRIC® RECTANGULAR PORTED, ECCENTRIC PLUG VALVES
PORT AREAS AND FLOW DATA**

SIZE	MODEL NO.	PORT AREA (SQ. IN.)	% OF STD. WT. PIPE	K	CV
1	5801R	.86	100	.65	37
2	5802R	1.6	100	.65	150
2 1/2	5825R	7.4	150	.60	240
3	5803R	7.4	100	.70	320
4	5804R	12.7	100	.71	570
5	5805R	24.6	120	.60	960
6	5806R	24.6	85	.80	1200
8	5808R	42.3	85	.85	2070
10	5810R	66.8	85	.83	3250
12	5812R	97.1	86	.82	4750
14	5814R	119	86	.90	6150
16	5816R	158	86	.90	8050
18	5818R	193	83	.90	10200
20	5820R	240	83	.90	12600
24	5824R	352	83	.90	18100
30	5830R	507	75	.90	28300
36	5836R	732	75	.90	40700

FORMULA FOR HEADLOSS IN A WATER LINE:

$$\Delta H = K \left(\frac{V^2}{2g} \right)$$

FORMULA FOR PRESSURE DROP IN A WATER LINE:

$$\Delta P = Sg \left(\frac{Q}{Cv} \right)^2$$

WHERE: ΔH = Head loss, ft. of water column
 K = Flow coefficient
 V = Flow velocity, ft./sec.
 g = Gravity, 32.2 ft./sec.²

ΔP = Pressure drop, psi
 Q = Flow rate, gpm
 Cv = Flow coefficient
 Sg = Specific gravity

DATA BASED ON INDEPENDENT LABORATORY TEST DATA.

Revised 5-17-00

RECTANGULAR PORTED, ECCENTRIC PLUG VALVE PORT AREAS AND FLOW DATA

DATE 8-5-96

VAL-MATIC® VALVE AND MANUFACTURING CORP.

DRWG. NO.
SS-1234

PLUG POSITION (PERCENT OPEN)

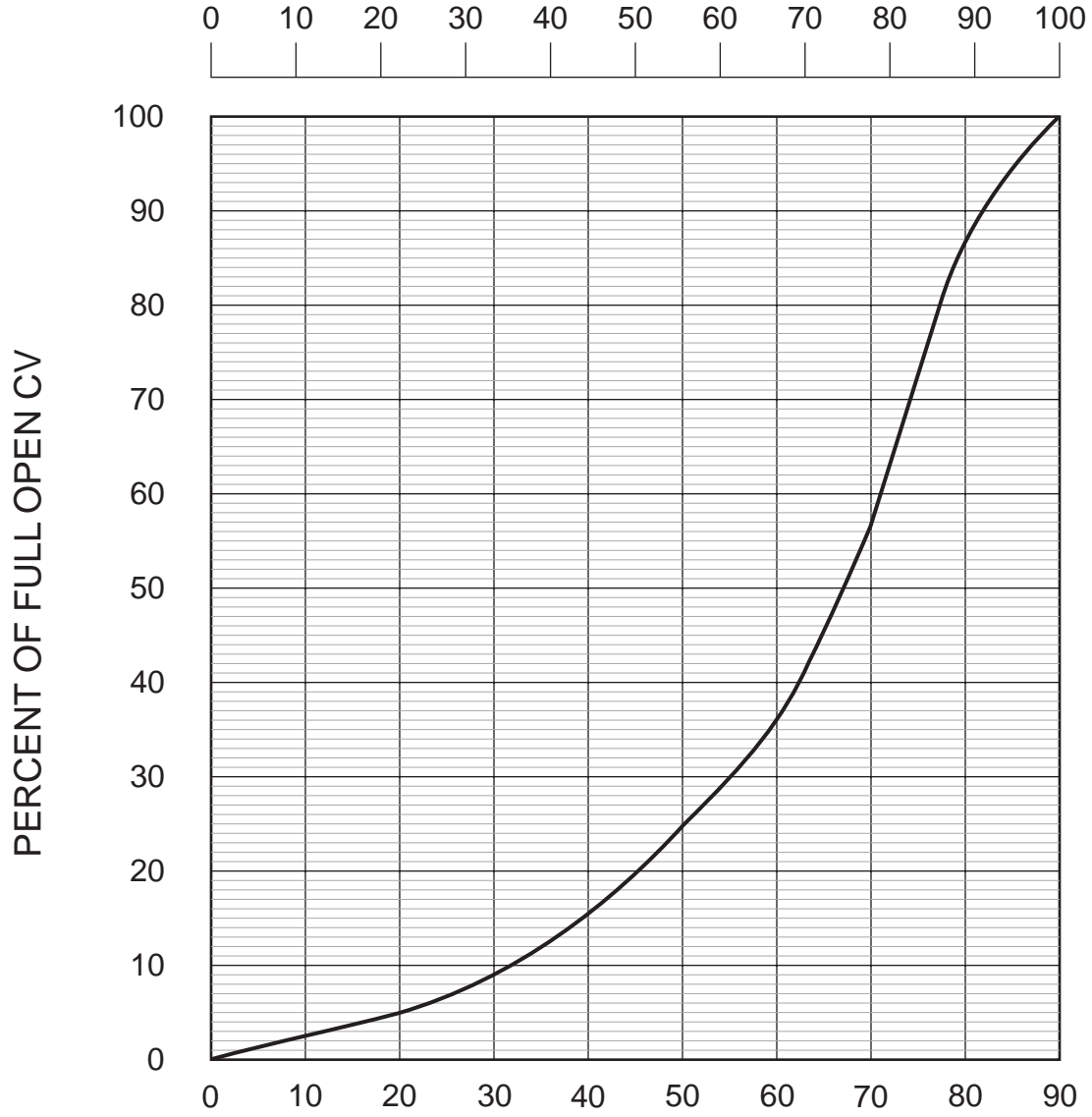

PLUG POSITION (DEGREES FROM CLOSED POSITION)

THE ABOVE GRAPH IS BASED ON INDEPENDENT LABORATORY TEST DATA.

Revised 4-13-98

FLOW CHARACTERISTICS OF CAM-CENTRIC® RECTANGULAR PORTED PLUG VALVES

DATE 7-22-97

VAL-MATIC® VALVE AND MANUFACTURING CORP.

DRWG. NO.
SS-1394

VALVE SIZE	Cv VALUES OF CAM-CENTRIC RECTANGULAR PORTED PLUG VALVES AT VARIOUS PLUG POSITIONS								
	10°	20°	30°	40°	50°	60°	70°	80°	FULL OPEN
1	1	2	3	6	9	13	21	32	37
2	5	7	12	23	38	52	85	131	150
2 1/2	8	12	20	37	62	84	135	210	240
3	10	16	26	50	83	112	180	280	320
4	18	28	47	89	147	199	322	498	570
5	30	47	79	150	247	335	541	839	960
6	38	59	100	187	309	419	678	1048	1200
8	65	102	170	323	534	723	1170	1808	2070
10	103	160	268	510	838	1130	1840	2840	3250
12	150	233	392	740	1220	1660	2680	4150	4750
14	194	300	510	960	1580	2150	3470	5370	6150
16	250	400	665	1250	2070	2810	4540	7030	8050
18	325	500	840	1590	2620	3565	5755	8910	10200
20	400	620	1040	1960	3240	4400	7100	11000	12600
24	570	890	1500	2820	4650	6320	10200	15800	18100
30	890	1390	2340	4410	7270	9900	16000	24700	28300
36	1280	2000	3360	6340	10450	14200	23000	35500	40700

* Cv = THE NUMBER OF U.S. GALLONS / MINUTE OF 60° WATER THAT WILL FLOW THRU THE VALVE WITH A 1 PSI PRESSURE DROP ACROSS THE VALVE.

THE FOLLOWING FORMULA CAN BE USED TO DETERMINE THE PRESSURE DROP ACROSS THE VALVE WHEN PLUG POSITION AND RATE OF FLOW ARE KNOWN.

$$\Delta P = Sg \left(\frac{Q}{Cv} \right)^2$$

WHERE: ΔP = Pressure drop across valve (psi)
 Q = Rate of flow (gpm)
 Cv = Value from the above chart
 Sg = Specific gravity of fluid (water = 1)

THE ABOVE CHART WAS COMPILED FROM INDEPENDENT LABORATORY TEST DATA.

Revised 5-15-03

Cv VALUES OF CAM-CENTRIC® RECTANGULAR PORTED PLUG VALVES AT VARIOUS PLUG POSITIONS

DATE 7-17-97

VAL-MATIC® VALVE AND MANUFACTURING CORP.

DRWG. NO.

SS-1395