

# Wastewater Surge Suppression Combination Air Valve

## Operation, Maintenance and Installation Manual

INTRODUCTION.....	2
RECEIVING AND STORAGE .....	2
DESCRIPTION OF OPERATION.....	2
INSTALLATION.....	3
VALVE CONSTRUCTION.....	3
MAINTENANCE .....	4
TROUBLESHOOTING .....	5
DISASSEMBLY .....	5
REASSEMBLY .....	5
PARTS AND SERVICE.....	6
WARRANTY.....	6



VAL-MATIC® VALVE AND MANUFACTURING CORP.

---

905 RIVERSIDE DR. ELMHURST, IL. 60126  
TEL. 630 / 941-7600 FAX. 630 / 941-8042

# WASTEWATER SURGE SUPPRESSION AIR VALVE OPERATION, MAINTENANCE AND INSTALLATION

## INTRODUCTION

This manual will provide you with the information to properly install and maintain the valve to ensure a long service life. The Wastewater Surge Suppression Air Valve has been designed with stainless steel trim to give years of trouble-free operation but regular maintenance is recommended for valves subject to fluids containing suspended solids or greases/oils. The valve is typically mounted at the high points in a piping system to automatically remove pockets of air as they accumulate. The valve can also be used to slowly release air in tanks and pump casings.

<b>CAUTION:</b> This valve is not intended for flammable liquids service.
---

The valve is a float-operated, resilient-seated valve designed to handle waste fluids. The valve may be equipped with backwash accessories for severe service. The Size, Maximum Working Pressure and Model No. are stamped on the nameplate for reference.

## RECEIVING AND STORAGE

Inspect valves upon receipt for damage in shipment. Handle all valves carefully without dropping. Valves should remain boxed, clean and dry until installed to prevent weather related damage. For long-term storage greater than six months, the valve must remain in the box and stored indoors. Do not expose valve to sunlight or ozone for any extended period.

## DESCRIPTION OF OPERATION

The Wastewater Surge Suppression Air Valve is designed to automatically remove air pockets at the high points in a piping system. The valve, as shipped, is a normally open valve and will vent air through the top opening. As fluid enters the valve, the float will rise, closing the plug. As air accumulates in the piping system and enters the valve, the float drops and pull the button away from the plug. This will allow pressurized air to be vented through the plug. In the case of rapid air exhaust, the regulated exhaust device on the outlet closes and restricts the outflow of the air.

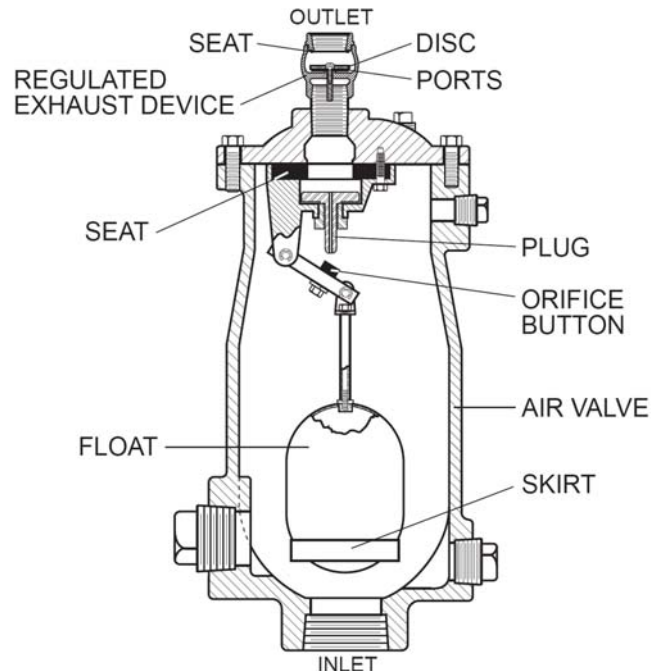

**FIGURE 1. WASTEWATER SURGE  
SUPPRESSION AIR VALVE**

When air enters the valve, it is released through the large-diameter seat and the outlet on the top of the valve. When fluid enters the valve, the float lifts the plug, which seals off the seat. The orifice button also seals against the small orifice drilled through the center of the plug. The float has a skirt to assist in closure and reduce leakage. As air or gas accumulates in the valve, the float will drop and pull the button away from the plug. This will allow pressurized air to be vented through the plug. Additional ports are provided for flushing, testing and draining purposes.

## INSTALLATION

The installation of the valve is important for its proper operation. Valves should be installed at the system high points in the vertical position with the inlet down. For pipeline service, a vault with freeze protection, adequate screened venting, and drainage should be provided. During closure, some fluid discharge will occur so vent lines should extend to an open drain area in plant service. A shut-off valve should be installed below the valve in the event servicing is required.

**CAUTION:** Install valve with "INLET" port down or leakage will occur.

## VALVE CONSTRUCTION

The standard Wastewater Surge Suppression Combination Air Valve consists of an air valve and a regulated exhaust device piped on the outlet. See the specific Materials List submitted for the order if other than standard cast iron construction. The general detail of construction for the air valve is illustrated in Figure 2 and listed in Table 1.

ITEM	DESCRIPTION	MATERIAL
1	Body	Cast Iron
2	Cover	Cast Iron
3	Baffle	Cast Iron
4	Seat*	Buna-N
5	Float*	Stainless Steel
6	Gasket*	Non-Asbestos
7	Cover Bolt	Alloy Steel
8	Retaining Screw*	Stainless Steel
10	Float Arm*	Stainless Steel
11	Orifice Button*	SS and Buna-N
12	Pivot Pin*	Stainless Steel
13	Retaining Ring*	Stainless Steel
14	Pipe Plug	Steel
16	Plug	Stainless Steel
17	Float Retainer*	Stainless Steel
18	Lock Nut*	Stainless Steel
20	Guide Shaft*	Stainless Steel
28	Pipe Plug	Malleable Iron
33	Clevis*	Stainless Steel
34	Lock Washer*	Stainless Steel
35	Guide Shaft Retainer*	Stainless Steel
36	Pipe Plug	Steel

\*RECOMMENDED REPAIR PART KIT

TABLE 1. AIR VALVE LIST OF PARTS

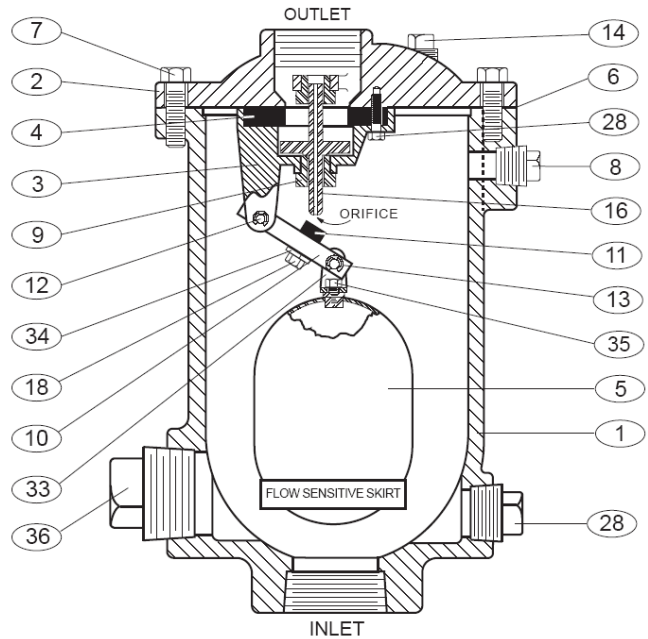

FIGURE 2. 1'-4" WASTEWATER COMBINATION AIR VALVE

The general detail of construction for the regulated exhaust device is illustrated in Figures 3 and 4 and listed in Tables 2 and 3.

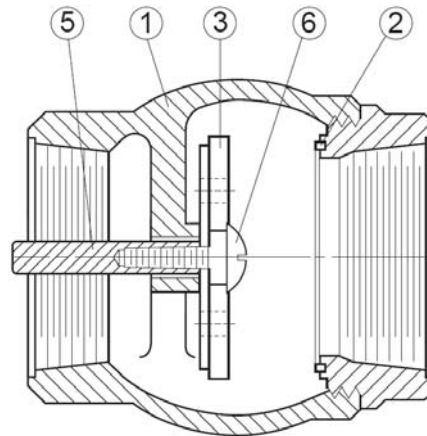
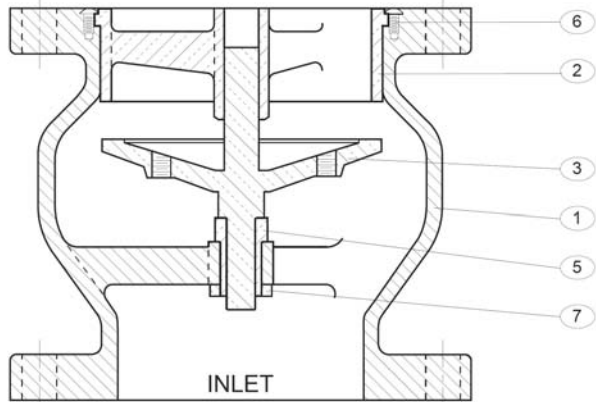

FIGURE 3. 1'-2" REG. EXH. DEVICE

ITEM	DESCRIPTION	MATERIAL
1	Body	Cast Iron
2	Seat	Bronze
3	Disc	Bronze
5	Stem	Brass
6	Seat Ret. Screw	Brass
*RECOMMENDED REPAIR PART KIT (Entire Device)		

**TABLE 2. 1"-2" REG. EXH. DEVICE PARTS**

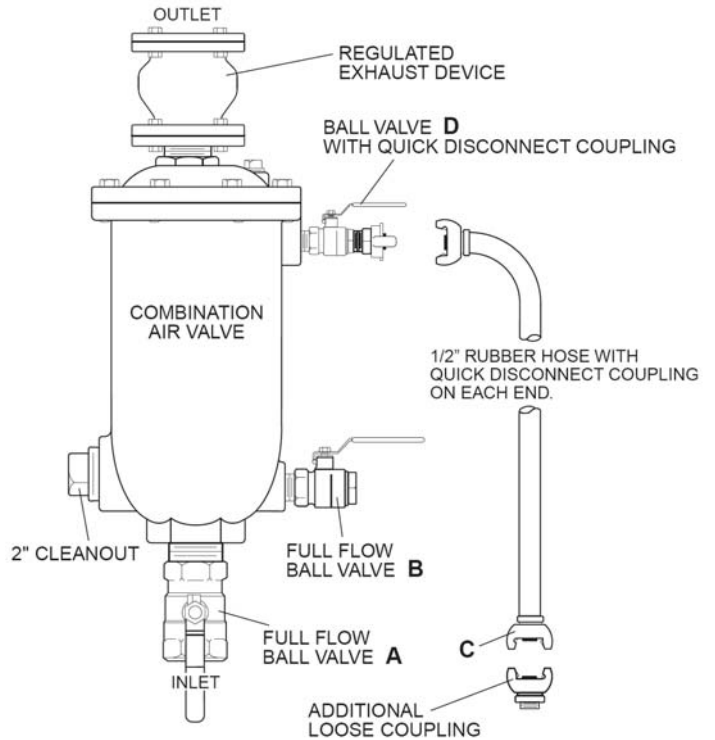

**FIGURE 4. 3"-4" REGULATED EXHAUST DEVICE**

ITEM	DESCRIPTION	MATERIAL
1	Body	Cast Iron
2	Seat*	Bronze
3	Disc*	Bronze
5	Bushing*	Bronze
6	Ret. Screw*	Stainless Steel
7	Retaining Nut*	Brass
*RECOMMENDED REPAIR PART KIT		

**TABLE 3. 3"-4" REG. EXH. DEVICE PARTS**

Backwash Accessory Kits			
Type	Inlet	Backwash Kit	Valve Models
Comb. Air Valve	1"	SPK-301ABW	801SSBW
	2"	SPK-301ABW	802SSBW
	3"	SPK-303ABW	803SSBW
	4"	SPK-804BW	804SSBW



**FIGURE 5. TYP. BACKWASH ARRANGEMENT**

**Option Backwash Assembly**

Refer to the Figure 5 for the correct piping arrangement. Please note the each kit contains extra fittings such as reducer bushings that may not be needed for your valve. The fittings should be installed with a standard pipe compound such as Oatey White Thread Sealant (supplied) or sealing tape. The quick disconnect fittings (Air King Universal Couplings) are designed for easy push and turn connections to a clean water source.

**MAINTENANCE**

The Wastewater Combination Air Valve should be scheduled for regular inspection and/or backwash on a quarterly basis. Based on experience in severe service, a more frequent backwash regimen may be desirable to minimize leakage.

**WARNING:** Wear safety glasses to look into the valve outlet after installation. Released fluid can cause injury.

**Inspection:** Periodic inspection to verify operation can be performed. The valve should not leak fluid at any connection or through the outlet. If there is leakage through the outlet, perform a backwash procedure on the valve. Also check to see that air is being released by cracking open the lower drain valve (B). If a large amount of air is released from the drain valve, then the main valve may be clogged and a backwash procedure should be performed.

**Lubrication:** The Wastewater Combination Air Valve is a self-contained automatic valve and does not require any lubrication to enhance its operation.

**Tools:** No special tools are needed to maintain or repair the valve. The valve can be equipped with backwash valves and hoses for ease of backwashing.

**Backwash Procedure:** In order to properly backwash the valve, a 1" clean water supply of at least 30 psi is needed. This supply should be connected to the rubber hose with quick disconnect couplings as provided with the wastewater valve and shown in Figure 5.

1. Pipe valve B to a drain prior to backwashing.
2. Close inlet valve A.
3. Open drain valve B.
4. Connect water supply to C/D and supply water for 3 minutes to flush seat and mechanism area.
5. Additional washing of seat area can be accomplished by placing the water supply over the discharge into the Outlet port.
6. Close valves D and B.
7. Slowly open valve A to place back in service.

## TROUBLESHOOTING

Several problems and solutions are presented below to assist you in troubleshooting the valve assembly in an efficient manner.

- **Leakage at Bottom Connection:** Tighten valve threaded connection. If leak persists, remove valve and seal threads with Teflon\* sealant or tape.
- **Leakage at Cover:** Tighten bolts per Table 4, replace gasket.
- **Valve Leaks when Closed:** Backwash valve to remove debris. Disassemble and inspect seat, orifice button, and float. NOTE: Many floats contain sand for weight but if water is detected, replace float.

- **Valve not Venting Air:** Check that operating pressure does not exceed Working Pressure on nameplate. Backwash or clean valve.

## DISASSEMBLY

The valve can be disassembled without removing it from the pipeline. Or for convenience, the valve can be removed from the line. All work on the valve should be performed by a skilled mechanic with proper tools. No special tools are required.

**WARNING:** The valve must be drained before removing the cover or pressure may be released causing injury.

1. See Figure 3. Close inlet shut-off valve (A). Open drain valve (B) or remove drain plug. See Figure 5. Unscrew the Regulated Exhaust Device from the top of the valve. Remove the cover bolts (7) on the top cover of the air valve as shown in Figure 2.
2. Pry cover (2) loose with sharp chisel or screwdriver and lift off valve body. The float will be connected to the cover.
3. Remove the retainer screws (28) and inspect the seat (4) and button (11) for cracks in the rubber or wear in the sealing surfaces.
4. Remove the plug (16) from the baffle (3). The small orifice through the plug should be clean. The plug shaft and bushing (9) ID should be polished clean with 4x0 steel wool or 320 grit polishing compound.
5. Turn guide bushing (9) to remove it from the baffle. Remove the retainer rings (13) to disassemble the float arm assembly.
6. Clean and inspect parts. Note: If floats contain water, replace. Replace worn parts as necessary.

## REASSEMBLY

All parts must be cleaned and gasket surfaces should be cleaned with a stiff wire brush in the direction of the serrations or machine marks. Worn parts, gaskets and seals should be replaced during reassembly. Refer to Figure 2.

1. Apply Loctite 680 thread sealant to guide bushing threads (9) and thread bushing into baffle (3).

2. Lay seat (4), plug (16), and baffle (3) over inverted cover and fasten with screws (28) with maximum torque of 10 ft-lbs. Do not over tighten.
3. Assemble float (5) with Loctite 680 on the threaded connections of float retainer (17) and guide shaft retainer (35).
4. Insert pivot pins (12) through float arm (10) and fasten with retainer rings (13). Thread in orifice button (11) and secure with lockwasher (34) and lock nut (18). Adjust orifice button so that when float is seated against the plug, the button is centered.
5. Lay cover gasket (6) over body flange and secure with lubricated bolts (7) to the torque shown in Table 2.
6. Place valve back in service. Refer to the installation instructions on page 2. Slowly open inlet isolation valve A as shown in Figure 5.

## PARTS AND SERVICE

Parts and service are available from your local representative or the factory. Make note of the valve Model No and Working Pressure located on the valve nameplate and contact:

Val-Matic Valve and Mfg. Corp.  
 905 Riverside Drive  
 Elmhurst, IL 60126  
 PH: 630/941-7600  
 FAX: 630/941-8042

A sales representative will quote prices for parts or arrange for service as needed.

Model Number	Bolt Size	Torque (ft-lbs)
801SS,	7/16"	30
802SS, 803SS, 804SS	1/2"	45

**TABLE 4. VALVE COVER BOLT TORQUES**

### LIMITED WARRANTY

All products are warranted to be free of defects in material and workmanship for a period of one year from the date of shipment, subject to the limitations below.

If the purchaser believes a product is defective, the purchaser shall: (a) Notify the manufacturer, state the alleged defect and request permission to return the product; (b) if permission is given, return the product with transportation prepaid. If the product is accepted for return and found to be defective, the manufacturer will, at his discretion, either repair or replace the product, f.o.b. factory, within 60 days of receipt, or refund the purchase price. Other than to repair, replace or refund as described above, purchaser agrees that manufacturer shall not be liable for any loss, costs, expenses or damages of any kind arising out of the product, its use, installation or replacement, labeling, instructions, information or technical data of any kind, description of product use, sample or model, warnings or lack of any of the foregoing. NO OTHER WARRANTIES, WRITTEN OR ORAL, EXPRESS OR IMPLIED, INCLUDING THE WARRANTIES OF FITNESS FOR A PARTICULAR PURPOSE AND MERCHANTABILITY, ARE MADE OR AUTHORIZED. NO AFFIRMATION OF FACT, PROMISE, DESCRIPTION OF PRODUCT OF USE OR SAMPLE OR MODEL SHALL CREATE ANY WARRANTY FROM MANUFACTURER, UNLESS SIGNED BY THE PRESIDENT OF THE MANUFACTURER. These products are not manufactured, sold or intended for personal, family or household purposes.



**VAL-MATIC® VALVE AND MANUFACTURING CORP.**

905 RIVERSIDE DR. ELMHURST, IL. 60126  
 TEL. 630 / 941-7600 FAX. 630 / 941-8042