

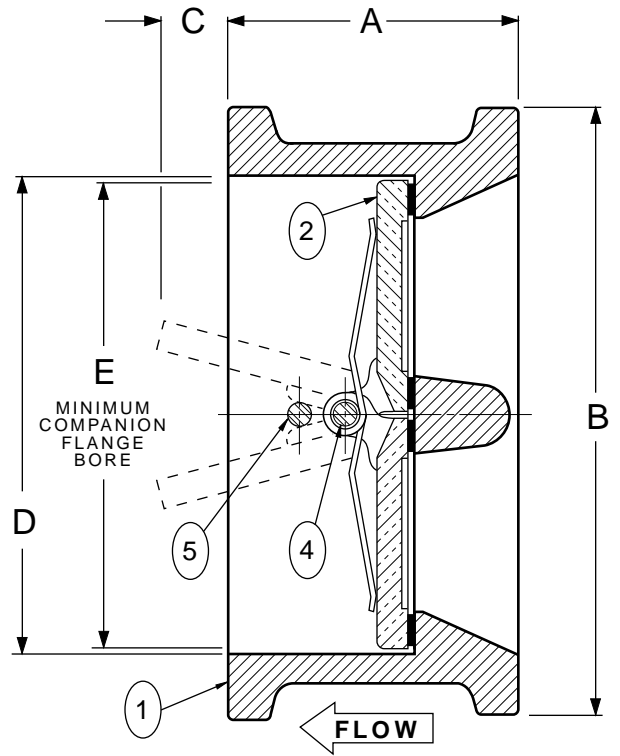

Approved

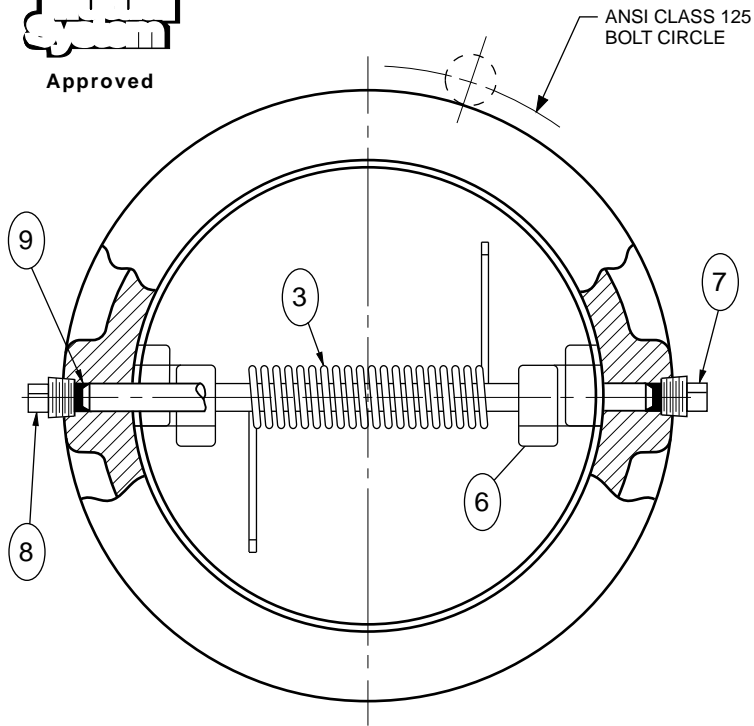

PART NO.	PART NAME
1	BODY
2	DISC
3	TORSION SPRING
4	DISC HINGE PIN
5	DISC STOP PIN

PART NO.	PART NAME
6	DISC THRUST BEARING
7	HINGE PIN RETAINER
8	STOP PIN RETAINER
9	STABILIZATION SPHERE

ANSI CLASS 125						
VALVE SIZE	MODEL NO.	A	B	C	D	E
2	8802.3	2 1/8	4 1/8	3/16	2 9/16	1 15/16
2 1/2	8825.3	2 3/8	4 7/8	5/16	3 1/16	2 5/16
3	8803.3	2 5/8	5 3/8	1/2	3 11/16	2 7/8
4	8804.3	2 5/8	6 7/8	1	4 5/8	3 7/8
5	8805.3	3 1/4	7 3/4	1 1/8	5 11/16	4 13/16
6	8806.3	3 3/4	8 3/4	1 1/4	6 3/4	5 3/4
8	8808.3	5	11	1 5/16	8 3/4	7 5/8
10	8810.3	5 1/2	13 3/8	2 1/2	10 7/8	9 9/16
12	8812.3	7 1/8	16 1/8	2 3/8	12 7/8	11 3/8

ANSI PRESSURE-TEMPERATURE RATING	
TEMP. ° F.	MAXIMUM NON-SHOCK PRESSURE PSI
	CLASS 125 CAST IRON
150°	200
200°	190
250°	175
HYDROSTATIC TEST PRESSURE	300

VAL-MATIC® DUAL DISC® CHECK VALVES CAN BE USED FOR HORIZONTAL FLOW OR VERTICAL FLOW-UP APPLICATIONS ONLY. CAUTION: FOR HORIZONTAL FLOW APPLICATIONS, VALVE MUST BE INSTALLED WITH THE DISC HINGE PIN IN THE VERTICAL POSITION. SEE DRAWING NO. VM-8802-M FOR 2"-12" STANDARD MATERIAL OF CONSTRUCTION. FOR 14" & LARGER VALVES, SEE DRAWING NOS. VM-8814 & VM-8836. FOR AIR SERVICE APPLICATIONS, SEE DRAWING NO. VM-8902. VAL-MATIC® DUAL DISC® CHECK VALVES CONFORM TO ANSI B16.1 SPECIFICATIONS.

Revised 1-27-03

ANSI CLASS 125 DUAL DISC® CHECK VALVE

DATE 3-26-98



VALVE AND MANUFACTURING CORP.

DRWG. NO.

VM-8802