

SEE DRWG. NO. VM-1H24-M FOR STANDARD MATERIALS OF CONSTRUCTION.

VALVE SIZE	150B MODEL NO.			250B MODEL NO.		
	HW	CHW	NUT	HW	CHW	NUT
42	1H24	1H24C	1H02	1H24	1H24C	1H02
48	1J24	1J24C	1J02	1J24	1J24C	1J02
54	1K24	1K24C	1K02	—	—	—
60	1K24	1K24C	1K02	—	—	—
66	1K24	1K24C	1K02	—	—	—
72	1L24	1L24C	1L02	—	—	—

NOTES

1. OPERATOR HOUSING AND BEVEL GEAR HOUSING CONNECTION SEALED WITH LIQUID GASKET.
2. THE DIRECTION OF OPENING MAY BE REVERSED BY SIMPLY CHANGING POSITION OF BEVEL GEAR AS SHOWN BY DOTTED LINES. SOLID LINES - OPEN LEFT. DOTTED LINES - OPEN RIGHT.
3. OPERATOR MEETS AWWA SPECIFICATIONS C-504, LATEST REVISION.

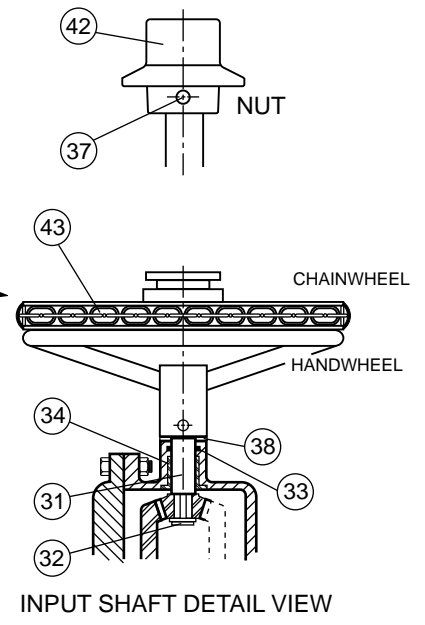
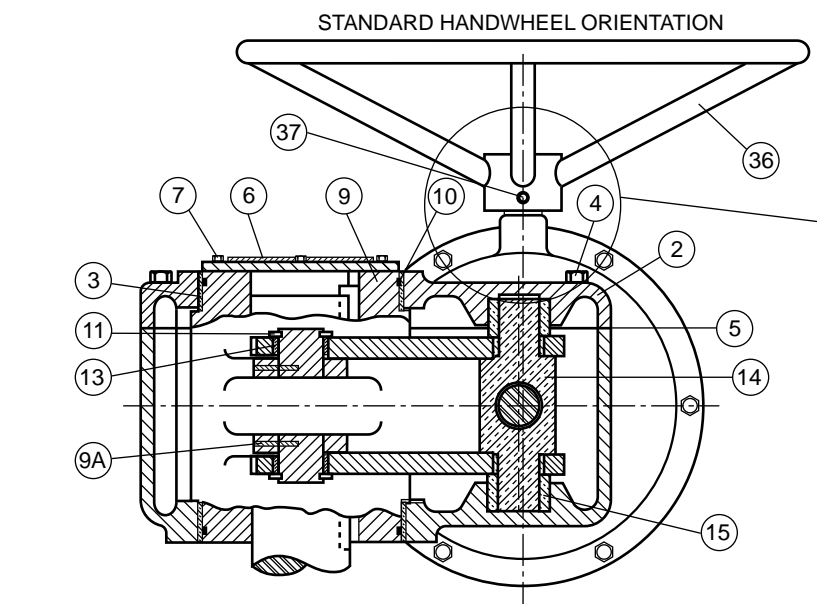

Revised 12-22-03

ABOVE GROUND SERVICE TRAVELING NUT ACTUATOR FOR BUTTERFLY VALVE

DATE 10-25-99

VAL-MATIC[®] VALVE AND MANUFACTURING CORP.

DRWG. NO. VM-1H24