

FLANGES, BOLTS, NUTS AND GASKETS ARE SUPPLIED BY OTHERS.

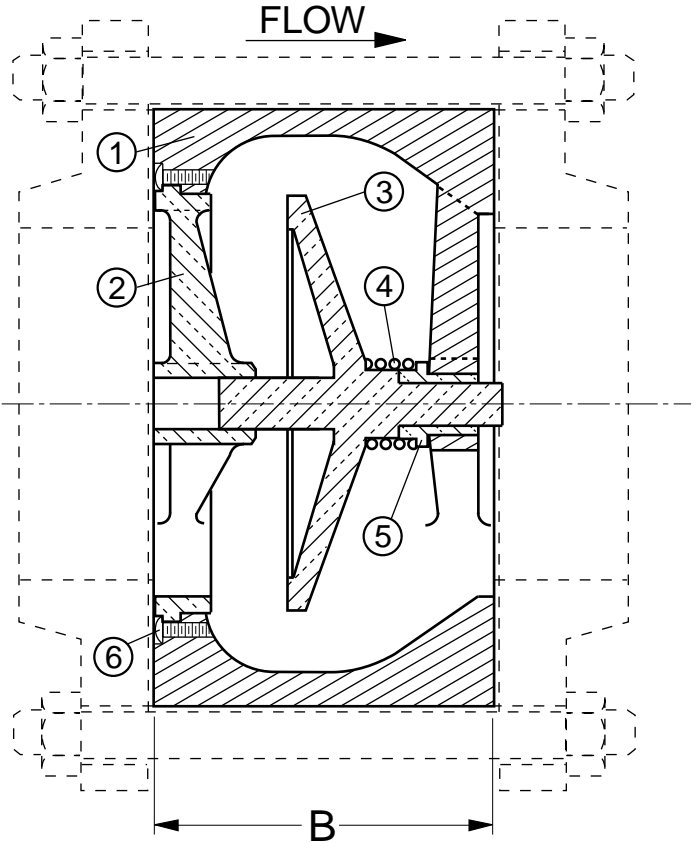
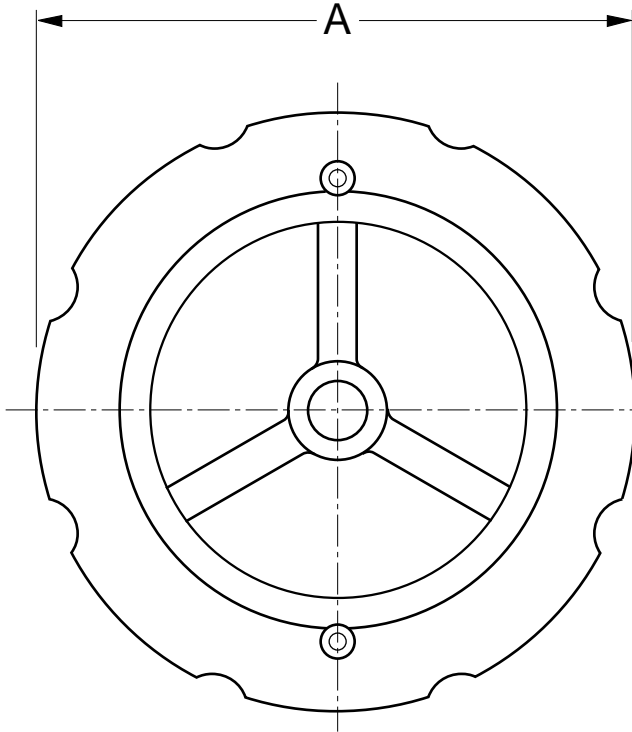

PART NO.	NAME
1	BODY
2	SEAT
3	DISC
4	SPRING
5	BUSHING
6	RETAINING SCREWS

Installation Requirements

Refer to drawing SS- 974 entitled Silent Check Valve Flange Installation Requirements for mating flanges.

SEE DRAWING NO. VM-1402-M FOR STANDARD MATERIALS OF CONSTRUCTION.

125 LB. CLASS				
VALVE SIZE	MODEL NO.*	CWP (P.S.I.)	A	B
8	1408	200	13 3/8	6 1/2
10	1410	200	16	8 1/4
250 LB. CLASS				
8	1458	400	13 3/8	6 1/2
10	1460	400	16	8 1/4

\* MODEL NUMBERS REFLECT BRONZE TRIM.

Revised 4-15-03

WAFER STYLE SILENT CHECK VALVE

DATE 4-1-67

**VAL-MATIC**<sup>®</sup>

VALVE AND MANUFACTURING CORP.

DRWG. NO.

VM-1408