

# Val-Matic® Tilted Disc® Check Valve

## Operation, Maintenance and Installation Manual

INTRODUCTION.....	1
RECEIVING AND STORAGE .....	1
DESCRIPTION OF OPERATION.....	1
INSTALLATION.....	2
VALVE CONSTRUCTION.....	3
MAINTENANCE .....	4
TROUBLESHOOTING .....	4
DISASSEMBLY .....	5
REASSEMBLY .....	5
OPTIONAL BMOD .....	8
OPTIONAL TMOD.....	11
OPTIONAL BYPASS.....	15
PARTS AND SERVICE .....	15
WARRANTY .....	15



VALVE AND MANUFACTURING CORP.

---

905 Riverside Dr. • Elmhurst, IL 60126  
Phone (630) 941-7600 • Fax (630) 941-8042  
[www.valmatic.com](http://www.valmatic.com)

# TILTED DISC<sup>®</sup> CHECK VALVE

## OPERATION, MAINTENANCE AND INSTALLATION

### INTRODUCTION

This manual will provide you with the information to properly install and maintain the check valve to ensure a long service life. The Tilted Disc Check Valve is ruggedly constructed with aluminum-bronze or stainless steel trim to give years of trouble free operation. The valve should be installed in water pipelines three diameters downstream of pumps to prevent reverse flow.

**CAUTION:** For valves with Top Mounted Dashpots, DO NOT paint exposed surfaces of the connecting rod or the cylinder piston rod or damage will result to the hydraulic seals.

The valve is designed to open after pump start and allow water to flow through the pipeline or water main while creating a minimal amount of headloss. A top or bottom mounted oil dashpot may be included to control the opening and closing of the valve. The valve size, cold working pressure, and model number are stamped on the nameplate for reference.

This valve is not intended for fluids containing suspended solids such as wastewater. For wastewater and other high turbidity applications, use Val-Matic Series 500 Swing-Flex<sup>®</sup> Check Valve.

**CAUTION:** The Tilted Disc Check Valve is not intended for use with sewage or fuel service.

### RECEIVING AND STORAGE

Inspect valves upon receipt for damage in shipment. Unload all valves carefully to the ground without dropping. When lifting, the valve should be lifted with straps or bolts in the flange holes. The valve should never be lifted by the dashpot assembly.

The valves should remain crated, clean and dry until installed to prevent weather related damage. For long-term storage greater than six months, the valves should be stored indoors or the ends of the valve should be sealed with plastic wrap to prevent weather related damage.

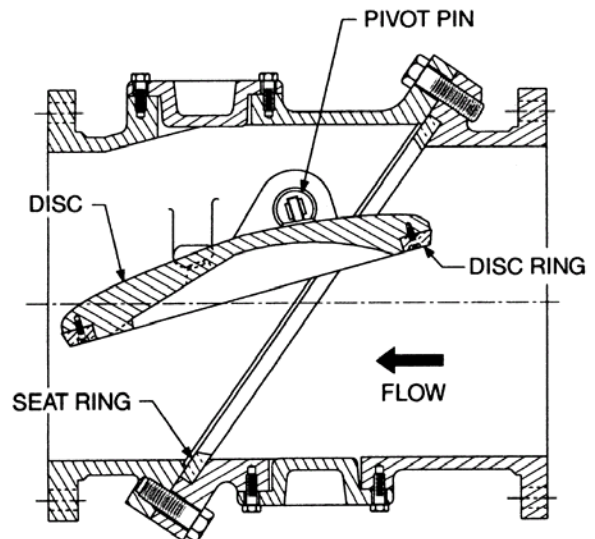

FIGURE 1. Tilted Disc<sup>®</sup> Check Valve

### DESCRIPTION OF OPERATION

The Tilted Disc Check Valve consists of two body sections bolted together at a central 55-degree diagonal flange assembly, forming a single valve body. The inlet body section contains a seat ring positioned and captured by the diagonal flanges. The outlet section contains two eccentrically located pivot pins from which a disc, containing a beveled disc ring, pivots 40 degrees from the closed to the fully open position.

The location of the eccentric pivot trunnions allows the seating surface of the disc ring to rotate away from the seating surface of the seat ring, without contact, when the valve opens. Conversely, during closing the seating surface of the disc ring moves into the seating surface of the seat ring without contact, until final sealing contact is made. A small amount of clearance exists between the pivot pin and the pivot pin bushing when the disc ring makes full contact with the seat ring to ensure a tight seal.

The flow area throughout the valve equals or exceeds the flow area of the pipe, thus minimizing the head loss through the valve.

## DESCRIPTION OF OPERATION (cont'd)

Upon pump start-up, the forward flow of water will start to rotate the disc about the pivot pins until the disc rotates through a 40-degree arc and contacts the integral body stops. The partially balanced disc assists in opening the disc and stabilizes the disc in low-flow cases where the valve remains partially open.

On pump shutdown, the forward velocity of the water starts to diminish, until the disc is no longer held against the body stops and the partially balanced disc will move to the closed position. When the forward velocity reaches zero, the disc will have moved to the closed position and the reversal of flow is checked. The 40-degree travel of the disc and the partially balanced disc reduces the potential for check valve slam and water hammer normally associated with conventional swing check valves.

However, ideal hydraulic conditions are not always predictable and the potential for water hammer can still exist. Applications with a potential for valve slam include high-head pumping, multiple high service pumps, and the use of hydro-pneumatic surge tanks. If the reversal of flow occurs before the disc has a chance to fully close, it will be driven to the closed position by the rapid flow reversal.

For these rapid flow reversal conditions, a bottom mounted hydraulic dashpot can be fitted in the bottom inspection port, provided that sufficient clearance is provided for installation. The bottom mounted oil dashpot will control the last 10 degrees of disc travel between 1 and 5 seconds. A top mounted dashpot can also be used. A top mounted oil dashpot performs the same function as a bottom dashpot and in addition, independently controls the full open and closing strokes between 5 and 30 seconds to prevent line surges.

## INSTALLATION

The installation of the valve is important for its proper operation. The Tilted Disc Check Valve can only be used for horizontal flow or vertical flow-up applications.

**CAUTION:** For horizontal flow applications, the valve must be installed with both of the eccentric pivot pin trunnions located above the horizontal centerline of the valve and they must be level to the horizontal plane of the valve.

Each valve is provided with a flow arrow integrally cast on the valve body and a flow arrow printed on the metal label attached to the valve. These flow arrows must point in the direction the water will flow, when the system is operating. ANSI Class 125 and Class 250 Cast Iron valves are furnished with flat

faced flanges and should be mated with flat faced companion flanges. The valve and adjacent piping must be supported and aligned to prevent cantilevered stress being transferred to the valve's flanges when installing the flange bolts or studs. For raised face applications, a ductile iron valve body should be specified.

**CAUTION:** The valve must be mated with flat-faced flanges or damage may result. The use of excessive bolt torque can damage the

When mating the check valve with butterfly isolation valves, the clearance between the butterfly disc and the fully open check valve stem must be checked. A spacer pipe is sometimes needed. See the valve arrangement drawing for disc clearance dimensions.

**FLANGED ENDS:** The flange should be mated with flat-faced pipe flanges equipped with resilient gaskets. When ring gaskets are used, the bolt material shall be ASTM A307 Grade B or SAE Grade 2 Carbon Steel. Higher strength bolts should only be used with full-face gaskets.

**INSTALLATION:** Lower valve into the pipeline using slings or chains around the valve body. Eye bolts or bars can also be used in the bolt holes. Lubricate the flange bolts and insert them around the flange. Lightly turn bolts until gaps are eliminated. The tightening of the bolts should then be done in graduated steps using the cross-over tightening method. Recommended lubricated torques for use with resilient gaskets (75 durometer) is given in Table 1. Do not exceed bolt rating or crush gasket more than 50 percent of its thickness.

125# FLANGE DATA			250# FLANGE DATA		
Valve Size (in)	Bolt Dia. (in)	Bolt Torque (ft-lbs)	Valve Size (in)	Bolt Dia. (in)	Bolt Torque (ft-lbs)
4	5/8	30-90	4	3/4	50-150
6	3/4	30-90	6	3/4	70-150
8	3/4	40-120	8	7/8	90-200
10	7/8	45-150	10	1	110-300
12	7/8	65-200	12	1 1/8	160-450
14	1	80-250	14	1 1/8	140-450
16	1	90-300	16	1 1/4	180-600
18	1 1/8	100-350	18	1 1/4	190-600
20	1 1/8	120-450	20	1 1/4	220-600
24	1 1/4	150-500	24	1 1/2	350-900
30	1 1/4	180-600	30	1 3/4	500-1500
36	1 1/2	250-750	36	2	700-2000
42	1 1/2	300-900	42	2	800-2500
48	1 1/2	400-900	48	2	900-1800

**TABLE 1. FLANGE BOLT TORQUES**

## VALVE CONSTRUCTION

The standard Tilted Disc Check valve is ruggedly constructed of cast iron. See the specific Materials List submitted for the order if other than standard iron construction. The internal metal components are aluminum bronze or stainless steel. The pivot pins (4) are fixed in the body (1) and support the disc (3). Grease fittings (23) are provided to allow regular lubrication of the pivot pin. The general details of construction are illustrated in Figure 2.

The body is flanged to connect to a pipe flange. The body consists of a pivot body half (1) and a seat pivot half (2). The seat (11) is held in place by the

two body halves. Top and bottom inspection hole covers (13) are provided for servicing the valves and to allow installation of dashpots. Do not remove the inspection covers while the pipeline is under pressure or the cover may release pressure suddenly.

**WARNING:** Removal of inspection covers without draining the pipeline and valve may cause serious injury.

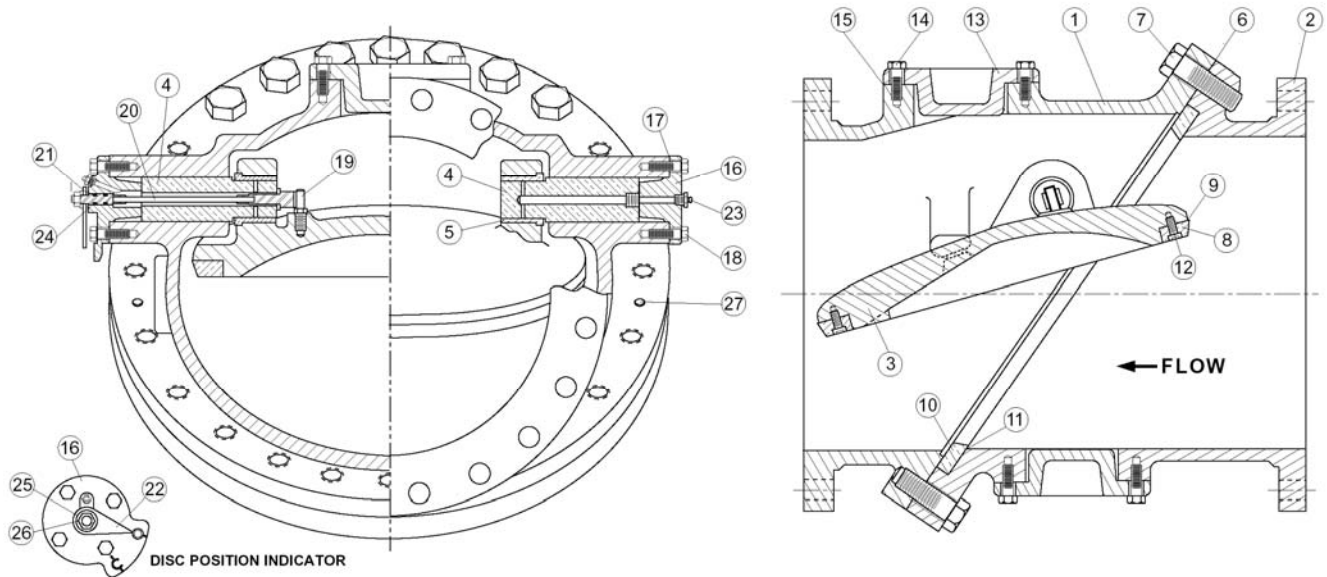

**Figure 2. Basic Valve Construction**

Part No.	Part Name	Material	Part No.	Part Name	Material
1	Pivot Body Half	Cast or Ductile Iron	16	Pivot Pin Cover	Cast Iron
2	Seat Body Half	Cast or Ductile Iron	17*	Pivot Pin Cover Gasket	Non-Asbestos
3	Disc	Cast or Ductile Iron	18	Pivot Pin Cover Bolt	Alloy Steel
4*	Pivot Pin	Alum. Brz.	19	Indicator Pin ( $\geq 6''$ )	Stainless Steel
5*	Pivot Pin Bushing ( $\geq 12''$ )	Alum. Brz.	20	Indicator Shaft Assy ( $\geq 6''$ )	Stainless Steel
6*	Body Gasket	Non-Asbestos	21	Indicator Washer ( $\geq 6''$ )	Stainless Steel
7	Body Flange Bolt	Alloy Steel	22	Indicator Pointer ( $\geq 6''$ )	Carbon Steel
8	Disc Ring ( $\geq 12''$ )	Alum. Brz.	23*	Grease Fitting	Stainless Steel
9	Ring Gasket ( $\geq 12''$ )	Non-Asbestos	24*	Indicator O-rings ( $\geq 6''$ )	Buna-N
10	Seat Ring	Alum. Brz.	25	Lock Washer ( $\geq 6''$ )	Stainless Steel
11	Seat Ring Gasket	Non-Asbestos	26	Indicator Jam Nut ( $\geq 6''$ )	Stainless Steel
12	Ring Ret. Screw ( $\geq 12''$ )	Stainless Steel	27	Locating Pins	Plated Steel
13	Inspection Cover ( $\geq 6''$ )	Cast Iron			
14	Cover Bolt ( $\geq 6''$ )	Alloy Steel			
15*	Gasket ( $\geq 6''$ )	Non-Asbestos			

\*Recommended Spare Part

## MAINTENANCE

The operation of the valve can be seen by observing the movement of the indicator pointer on the side of the valve (6" and larger sizes). The valve should move about 40 degrees from the closed to the fully open position. It is normal for the valve to not fully open in cases where the fluid velocity is less than 8 ft/sec or a Top Mounted Oil Dashpot is installed.

Dashpot assemblies require regular maintenance. See the dashpot section in this manual.

**LUBRICATION:** The Tilted Disc Check Valve is provided with grease fittings (23) located on the pivot pin covers. The valve's pivot trunnions must be lubricated at least monthly or as conditions dictate with a waterproof, FDA or ANSI/NSF 61 approved grease such as Lubriko #CW-606 (Master Lubricants Co., Philadelphia, Pa). Using a cartridge grease gun, pump grease into each grease fitting using 8 full strokes of the grease gun lever.

**INSPECTION:** Periodic inspection for leakage can be performed by placing a listening device or an ear on the valve while it is closed and the line is under pressure. If leakage is heard, close the isolation valve and drain the valve connection, and inspect the seating surfaces for wear or mineral deposits. Clean, or repair trim as needed.

**WARNING:** Removal of inspection covers without draining the pipeline and valve may cause serious injury.

The inspection hole covers can be removed from the valve to facilitate internal inspection of the valve. A hoist or jacking mechanism should be used to lift the disc to inspect the seating surfaces. If replacement of the disc, pivot pin bushings, disc ring, or seat ring is required, the valve must first be removed from the line.

## TROUBLESHOOTING

Several problems and solutions are presented below to assist you in trouble shooting the valve assembly in an efficient manner.

**TROUBLESHOOTING BASIC VALVE:** The valve opens automatically without the need of a power source to allow forward flow. The valve may not open to the full open position depending on fluid velocity but it will always open far enough to pass the flow with a minimal headloss. The valve will automatically close to prevent reverse flow through the pump. The valve has metal seats and a moderate bang during closing is normal.

1. Leakage at Valve Inspection Covers (13): Re-tighten bolts evenly or replace non-asbestos sheet gasket.
2. Leakage at Grease fitting: Inject grease or replace grease fitting (23).
3. Leakage at Mating Flanges: Re-tighten bolts using the cross-over method or replace mating flange gasket. Flange gaskets are typically 70 durometer resilient material. Check alignment of mating pipe.
4. Valve Leaks when Closed: Flush debris from seat by cycling valve. Verify that valve is subject to a minimum differential pressure of at least 10 psi when closed and the isolation butterfly or gate valve is open. If leakage persists, inspect interior of valve. Clean seating surfaces. When used with a power operated control valve, there may not be sufficient reverse flow to seat the valve. These types of installations require a power outage for proper valve seating so that the pump is tripped while the control valve is open.
5. Valve Fails to Open: Check pressure differential across disc; upstream pressure must be greater than downstream pressure. Verify that the suction and discharge shutoff valves are open and there is no line blockage. Drain pipe on both sides of the valve, remove inspection cover (13), and inspect disc ring (8) and seat ring (10) for damage or wedged debris.
6. Noisy Operation: Flow noise is normal. Loud flow noise similar to hammering may be cavitation from dropping high pressures across valve; review flow velocity through valve and pump application.

## DISASSEMBLY OF BASIC VALVE

The valve should be removed from the pipeline for disassembly. All work on the valve should be performed by a skilled mechanic with proper tools. Refer to Figure 2.

**WARNING:** The line must be drained before removing the valve or pressure may be released causing injury.

1. Lay valve on flat surface or bench with the inlet flange face down.
2. Using a flat-nosed punch, drive out the two locating pins (27).
3. Remove the indicator jam nut (26), lockwasher (25), pointer (22), pivot pin cover bolts (18) and covers (16).
4. Remove the pivot pins (4). The end of the pin is tapped for insertion of a 9/16"-18 or 3/4"-16 threaded rod.
5. Attach a hoist to the outer flange of the valve to support the weight of the outlet body section of the valve and remove the diagonal flange bolts (7).
6. Using the hoist, raise the outlet body section of the valve. If the valve sections are joined tightly by the gasket, lift the valve 1/8" and hammer the inlet body section down with a soft-blow hammer or block of wood. Once the body sections are separated, raise the outlet section to clear the disc pivot trunnions and place the outlet section on a wooden skid.
7. Remove the pivot pin bushings (5) from the disc pivot trunnions on 12" and larger valves. They may be set in place with sealant so apply heat to the disc trunnions with a propane torch to soften the Loctite if necessary.
8. Thread an eye bolt into one of the threaded holes in the disc's rectangular pad. Using a nylon sling through the disc trunnions and eye bolt, lift the disc straight up while maintaining its 55 degree tilt.
9. Place the disc on a wooden skid and using the nylon sling through just the eye bolt, turn the disc over with the disc ring (8) facing up.

All parts can now be easily inspected for wear or damage and replacement parts can be ordered as needed. If replacing the seat (10) or disc ring (8), it is recommended that they be replaced as a set. The pivot pins (4) should fit tightly in the body, but there should be ample clearance (at least 1/32") between the pins (4) and the bushings (5).

## REASSEMBLY OF BASIC VALVE

All parts must be clean and gasket surfaces should be cleaned with a stiff wire brush in the direction of the serrations or machine marks. Worn parts, gaskets, and seals should be replaced during reassembly.

1. Place the seat body half (2), with the inlet flange face down on a wooden skid.
2. Install a lightly lubricated seat ring gasket (11) in the register of the seat body half.
3. Install the seat ring (10) with the serrated surface toward the gasket, into the register of the body seat half.
4. With the disc on a wooden skid, and the disc ring register up, place a lightly lubricated disc ring gasket (9) onto the disc register and align the holes in the gasket with the tapped holes in the disc.
5. Assemble the disc ring with the serrated face toward the gasket.
6. Place a small amount of Loctite thread locking compound on each of the retaining screws (12) and thread them into the tapped holes in the disc. Tighten them initially hand tight and then using the cross-over tightening method, torque each screw in graduated steps, according to the following chart.

Valve Sizes	Torque
12" to 14"	13 ft-lbs
16" to 24"	20 ft-lbs
30"	28 ft-lbs
36" and larger	40 ft-lbs

7. Thread in eye bolt into one of the threaded holes in the disc's rectangular pad. Insert a nylon sling through the eye bolt and attach the loops of the sling to the hook of a hoist. Carefully turn over the disc, using the hoist, making sure that the beveled seating surface of the disc ring does not make contact with metal or hard surfaces.
8. Install the pivot pin bushings into the disc pivot trunnions with Loctite 680.
9. Remove the nylon sling from the eye bolt and place it through the disc's pivot trunnions bores and attach the loops of the sling to the hoist. Attach a short chain from the hoist's hook to the eyebolt and adjust the length of the chain to keep the disc at a 55 degree angle when housing the disc.

## REASSEMBLY OF VALVE (Cont'd)

10. Slowly lower the disc into the beveled seat ring, using care not to drop or allow the disc to swing into the seat ring. After the disc is in place, carefully align the disc's pivot trunnions, so they are at equal distance from the diagonal flange locating pin holes and that the disc ring is parallel to the seat ring.
11. Lightly lubricate and install the diagonal flange gasket on the face of the seat body half diagonal flange and align the holes in the gasket with the holes in the flange. The two small holes must be aligned with the two locating pin holes (27).
12. Install two temporary slip-fit locating pins into the seat body half's diagonal flange. Hoist the pivot body half over the seat body half and lower the diagonal flange with 1/2" of the mating flange. Align the locating pin holes (27). Once the diagonal flanges are aligned, the pivot body half can be lowered.
13. Apply a lubricant to the flange bolt threads (7). Once all of the diagonal flange bolts are inserted, tighten them hand tight. The torquing of the diagonal flange bolts should then be done in three graduated steps using the cross-over tightening method to load the bolts evenly.
14. Remove the temporary slip-fit locating pins from the diagonal flange and install the permanent locating pins (27).
15. Insert the indicator shaft assembly (20) through the 9/16" diameter hole in the indicator pivot pin (19) and insert the assembly into the body trunnions bore. Align the slot in the indicator pin, which is threaded into the disc. Install the pivot pin into the opposite trunnions bore.
16. Install the two indicator o-ring seals into the grooves of the indicator shaft. Make sure that the seals are not twisted within the grooves. Apply some grease on the seals. Lightly lubricate the pivot pin cover gasket and place it on the machined face of the indicator pin cover (16) and install the cover (16) over the indicator shaft. Insert the pivot pin cover bolts (18) and tighten hand tight. The torquing of the bolts should be done in two graduated steps using the cross-over tightening method to load the bolts evenly.
17. Install the external indicator washer (21) over the indicator shaft. Place the indicator pointer (22) on the end of the indicator shaft. The pointer should point toward the letter "C" cast on the indicator pivot pin cover. Slip the indicator lockwasher (25) and jam nut (26) while holding the indicator pointer. Do not over-tighten.
18. Lightly lubricate the opposite pivot pin cover gasket (17) and place it on the machined face of the pivot pin cover (16) and install the cover to the other pivot body half's trunnions boss. Insert the pivot pin cover bolts (18) and tighten hand tight. The torquing of the bolts should be done in two graduated steps using the cross-over tightening method to load the bolts evenly.
19. Lightly lubricate the inspection hole gasket (15) on the machined face of the inspection hole cover (13) and install the cover to the inspection hole port located on each body half. Insert the cover bolts (14) and tighten hand tight. The torquing of the bolts should be done in two graduated steps using the cross-over tightening method to load the bolts evenly.
20. The pivot trunnions must be lubricated with a waterproof, FDA approved grease, as outlined in the maintenance section. Install grease fittings (23) and pump grease into each fitting until the grease is observed at the interface of the pivot pin bushing's inside diameter (5) and the pivot pin's outside diameter (4).
21. Operate the valve several times, with the use of a hoist, to ensure correct operation before re-installing the valve.

## OPTIONAL BOTTOM DASHPOT

**DESCRIPTION:** The Bottom Mounted Oil Dashpot (BMOD), when required, is installed in the bottom inspection port of the Tilted Disc Check Valve. This unit provides control of the disc's final 10% of travel to the close position to reduce water hammer normally associated with rapid flow reversal conditions that exist on pump shut down. The unit consists of a high-pressure hydraulic cylinder, adjustable flow control valve, pressurized oil reservoir and piping.

A dashpot spacer which provides an air gap, connects the hydraulic cylinder and the dashpot cover, to prevent pressurized hydraulic fluid from entering the valve housing and contaminating the water system. The dashpot cover contains a snubber rod bushing and snubber rod which contacts the disc and the spring retainer assembly that is attached to the piston rod of the hydraulic cylinder.

**OPERATION:** Upon start-up, the forward flow of the water will open the check valve. The snubber rod is extended by the piston spring and the pressurized hydraulic fluid in the cylinder. On pump shutdown, the reversal of flow will close the check valve. Prior to the valve fully closing, the disc will make contact with the snubber rod and the hydraulic fluid will slowly bleed through the adjustable flow control valve, thus allowing the disc to move slowly into the seat. Some reverse flow and pump backspinning may occur during this process.

**INSTALLATION:** The BMOD may be installed at the factory (valves larger than 12") or it may be installed in the field as follows.

1. Remove the valve bottom inspection hole cover (13) and gasket (14).
2. Clean the gasket residue from the face of the inspection hole port.
3. Place the o-ring (70) into the groove of the dashpot cover (60).
4. Install the dashpot unit into the inspection hole port, aligning the snubber rod bushing to the notch in the inspection hole port.
5. Install the dashpot cover bolts (14) and tighten.
6. Start the unit with the flow control valve (38) in the full open position (fully counterclockwise).

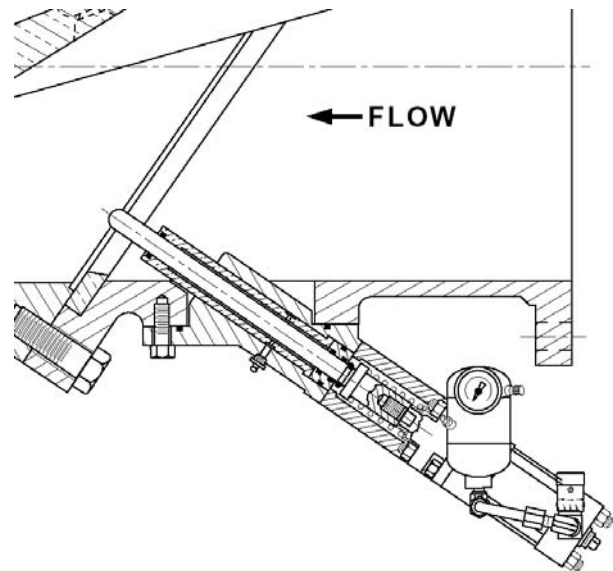

**Figure 3. Bottom Mounted Oil Dashpot**

7. The BMOD has been filled with oil at the factory. Using a bicycle tire pump inject air into the air fitting (55) until the pressure is 50 psi higher than the water system pressure on the discharge side of the check valve. The air pressure acts to counter-balance the force created by the internal water pressure acting on the area of the snubber rod (63). The air pressure and spring (71) work to extend the snubber rod when the check valve opens.
8. Start the pump and allow the check valve to fully open.
9. Shut down the pump and observe the action of the valve closure. If a slam occurs, the flow control valve can be gradually turned down (clockwise), until optimum operation is achieved, see Figure 9. The BMOD unit is designed to control the closing time between 1 and 5 seconds.

**CAUTION:** Flow control valves should not be used at settings below the blue band (second from the bottom). Lower settings will allow small particles of silt present in the hydraulic fluid to clog the valve and cause the BMOD to bind and result in damage to the valve or dashpot.

## OPTIONAL BOTTOM DASHPOT (Cont'd)

It is recommended that the person making adjustments to the flow control valve be familiar with the sounds created by water hammer and valve slam and not confuse them with the metallic sounds created by the valve upon metal seat closure. An over control situation should be avoided so that cavitation (loud rumbling) does not occur. After setting the flow control valve, tighten the locknut or set screw on the valve. Record the flow control valve setting and air pressure for future reference.

Valve Size	FCV Setting	Air Pressure

### CHECKING OIL AND GREASE LEVELS:

1. The check valve should be closed.
2. The air in the oil reservoir must be bled from the reservoir, using the air valve mounted on the reservoir.
3. Remove the pipe plug from the oil reservoir fill port.
4. Add hydraulic fluid equal to Mobil #DTE 24 until fluid is up to level indicated on the reservoir. Replace pipe plug.
5. Recharge the reservoir with air pressure to a minimum of 50 psi over the water line pressure.
6. The grease level can not be checked but it is recommended that the grease fitting be charged with grease twice a year. Use a cartridge grease gun and pump grease into the fitting using two full strokes. An FDA approved grease such as Lubriko #CW-606 should be used (Master Lubricants Company, Philadelphia, PA)

**DASHPOT SEAL REPLACEMENT:** There are several seals in the unit that may require replacement.

**TROUBLESHOOTING VALVE WITH BOTTOM MOUNTED OIL DASHPOT:** The bottom mounted oil dashpot engages the disc for the last 10% of travel and the flow control valve (38) controls the speed of closure in the 1-5 second range.

1. Leakage of Oil: Wipe down controls and identify the location of the leak. Tighten fittings where needed. Cylinder seal kits can be used if cylinder leakage persists.
2. Leakage of Air: With a minimum of 50 psi in the tank, apply soap solution to tank, gauge, and pipe plug and observe bubbles. Tighten fittings where needed. Replace gauge or pipe plug using Loctite PST pipe sealant (allow 4 hrs for full cure).
3. Valve Does Not Close Fully: Check air pressure in reservoir; the pressure should be 50 psi over the water line pressure. Open flow control valve further to allow greater oil flow. Readjust flow control valve until slam is diminished. A differential pressure across of the disc of at least 10 psi is typical for dashpot valves. If the pressure is lower, the dashpot is probably not needed and may interfere with valve operation. Start and stop pump again with the isolation butterfly or gate valve fully open.
4. Valve Slams Closed: Dashpot should prevent slamming by controlling the last 10% of valve closure. Throttle down the flow control valve to slow down valve closure. If problem persists, the snubber rod (63) may not be extending. The extension can be viewed through the 3/8" diameter drain holes in the dashpot spacer (62). Apply grease to grease fitting (23) in dashpot. Increase air pressure in 25 psi increments to 150 psi over line pressure. If problem persists, remove, disassemble, clean, and install new seals in dashpot assembly; apply lubricant to seals and sliding surfaces before installation.

### INSTALLING NEW DASHPOT SEALS:

1. Depressurize and drain the valve and pipeline.
2. Remove the dashpot from the valve and remove the 4 nuts holding the dashpot spacer.
3. Replace the (2) rod wipers (68) and o-ring seals (66 and 67).
4. If the oil cylinder is leaking oil, tighten the tie rod nuts. The cylinder should be returned to the factory for rebuilding if leakage persists.
5. Reinstall and charge the unit with air as listed above for a new unit.

## OPTIONAL BOTTOM DASHPOT Cont'd)

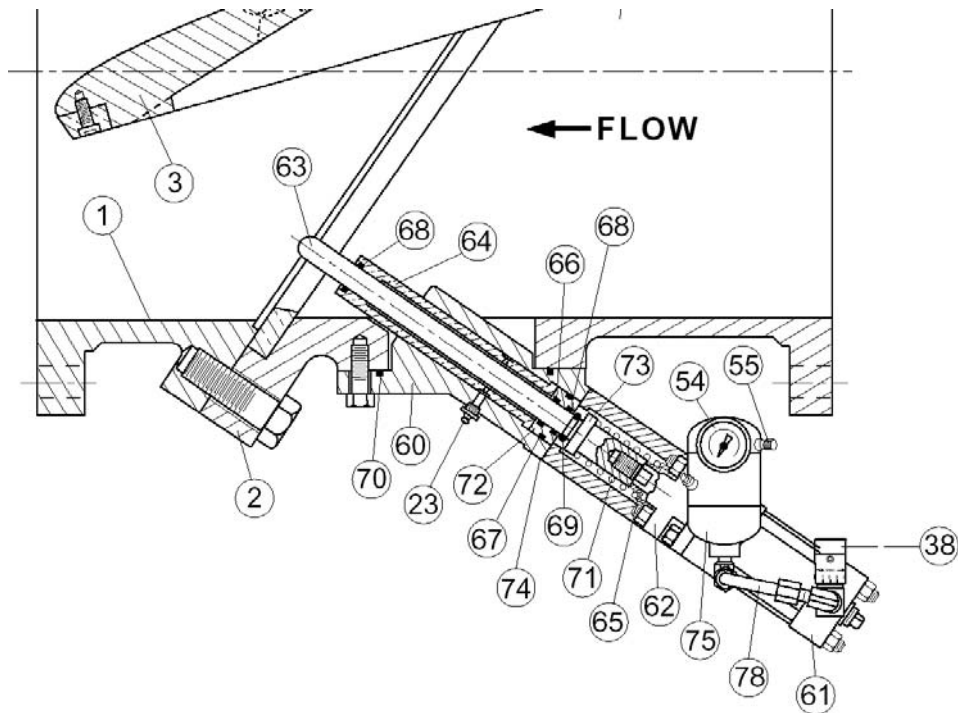

**FIGURE 4. Bottom Mounted Oil Dashpot (BMOD) Construction**

<u>Part No.</u>	<u>Part Name</u>	<u>Material</u>	<u>Part No.</u>	<u>Part Name</u>	<u>Material</u>
1	Pivot Body Half	Cast or Ductile Iron	66*	Snubber Rod O-Ring	Buna-N
2	Seat Body Half	Cast or Ductile Iron	67*	Bushing O-Ring	Buna-N
3	Disc	Cast or Ductile Iron	68*	Rod Wiper	Molythane
38	Flow Control Valve	Brass	69*	Retaining Ring	Buna-N
54*	Pressure Gauge	Brass	70*	Cover O-Ring	Buna-N
55*	Air Inlet Valve	Stainless Steel	71	Spring	Steel (plated)
60	Dashpot Cover	Ductile Iron	72	Lower Bushing	Bronze
61	Dashpot Cylinder	NFPA, Steel	73	Spring Retainer	Stainless Steel
62	Dashpot Spacer	Ductile Iron	74	Mounting Screw	Alloy Steel
63	Snubber Rod	Stainless Steel	75	Oil Reservoir	Carbon Steel
64	Snubber Rod Bushing	Alum Bronze	78	Dashpot Piping	Steel
65	Spring Guide	Alum. Bronze			

\*Recommended Spare Part

## OPTIONAL TOP DASHPOT

**DESCRIPTION:** The Top Mounted Oil Dashpot (TMOD), when required, is installed in the top inspection port of the Tilted Disc Check Valve and is attached with linkage to the disc. This unit provides single-stage speed control of valve opening and two-stage speed control of valve closing to reduce pressure surges on pump start-up and shut-down. The dashpot unit consists of a high-pressure oil hydraulic cylinder, two adjustable flow control valves, a pressurized oil reservoir, a non-pressurized oil reservoir, and piping. A dashpot spacer which provides an air gap, connects the hydraulic cylinder and the dashpot cover, to prevent pressurized hydraulic fluid from entering the valve housing and contaminating the water system. The dashpot spacer also contains the connecting rod bushing, bushing retainer plate and screws, o-ring seals, external and internal rod wipers, and the connecting rod which is connected to the piston rod of the hydraulic cylinder with a special quick coupling assembly. The connecting rod is attached to the check valve disc via links and pins.

**OPERATION:** Upon start-up, the forward flow of the water will open the check valve. The hydraulic fluid within the top portion of the dashpot cylinder is slowly bled through the top external flow control valve, until the valve travels to the full open position.

On pump shutdown, the reversal of flow will start to drive the disc to the closed position. For the first 90% of the disc travel, the hydraulic fluid within the bottom portion of the dashpot cylinder is slowly bled through the bottom flow control valve. The cylinder's internal cushion plunger then enters the cushion cavity located in the head of the hydraulic cylinder, provides a finer speed control (second stage) over the final 10% of disc travel to the closed position.

**INSTALLATION:** Follow the installation instructions for the basic valve for installation of the valve in the line. Use the following steps to start up the TMOD.

1. The external flow control valves should be set in the full open position (counterclockwise).
2. The cylinder's internal cushion adjustment screw in the face of the head is factory set at 4 turns from being bottomed out, see Figure 6.
3. The dashpot has been filled with oil in the factory and no additional fluid is required unless external leakage is observed. (See maintenance section on how to check fluid level).
4. Using a bicycle pump, charge the pressurized reservoir until the air pressure equals 20% of the water pressure on the discharge or downstream side of the check valve.

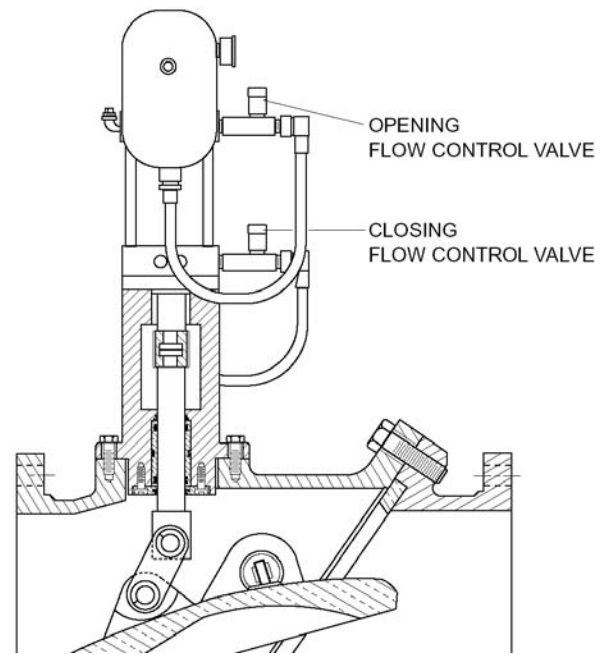

**Figure 5. Top Mounted Oil Dashpot (TMOD)**

5. Start the pump and observe the action of the valve through the opening cycle and allow the water system pressure to stabilize.
6. Shut down the pump and observe by sound and by observing the indicator the closing action of the valve.
7. If pressure surging is observed on the valve opening or if water hammer noises exist on valve closure, the appropriate external flow control valve can be gradually turned to a smaller number setting until optimum valve operation is achieved, see Figure 9. The unit is designed to control the operating time between 5 and 30 seconds.

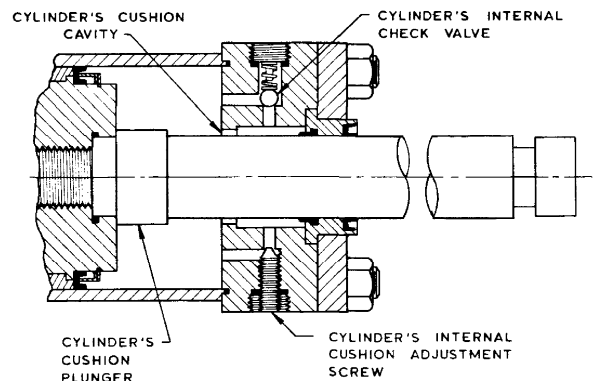

**Figure 6. Internal Cushion Adjustment**

## OPTIONAL TOP DASHPOT (Cont'd)

**CAUTION:** Flow control valves should not be used at settings below the blue band (second from the bottom). Lower settings will allow small particles of silt present in the hydraulic fluid to clog the valve and cause the TMOD to bind and result in damage to the valve or dashpot.

It is recommended that the person making adjustments to the flow control valve be familiar with the sounds created by water hammer and valve slam and not confuse them with the metallic sounds created by the valve upon metal seat closure. An over control situation should be avoided so that cavitation (loud rumbling) does not occur. After setting the flow control valve, tighten the locknut or set screw on the valve. Record the flow control valve setting and air pressure for future reference.

Valve Size	Open FCV Setting	Close FCV Setting	Air Pressure

**MAINTENANCE:** The Top Mounted Oil Dashpot (TMOD) unit should be checked occasionally for the proper air pressure within the pressurized oil reservoir while the TDCV is in the fully closed position. The air pressure should be maintained at a pressure equal to 20% of the water system pressure on the discharge or downstream side of the valve. If the air pressure can not be maintained, the leak within the dashpot unit must be found and corrected. The hydraulic fluid level within the pressurized oil reservoir and non-pressurized reservoir does not have to be checked unless external leakage is observed. The source of leakage must first be repaired and then the fluid level checked. A small amount of pipe thread sealant such as Loctite PST should be used on clean threads to ensure a tight joint. Allow approximately a one hour period for the sealant to set before depressurizing the unit.

### CHECKING OIL AND GREASE LEVELS:

1. The check valve should be closed. The pump should be locked out to prevent startup.
2. The air in the pressurized oil reservoir must be bled from the reservoir, using the air valve mounted on the reservoir.
3. Remove the pipe plugs from both reservoir fill ports.
4. Slowly add hydraulic fluid equal to Mobil #DTE 24 until fluid is up to the levels indicated on the reservoirs. Replace pipe plug with thread sealant Loctite PST.
5. Using the air connection, recharge the pressurized oil reservoir to 20% of the water pressure on the downstream side of the check valve.
6. Restore power to the pump.

**GREASE:** The TMOD unit is provided with a grease fitting located on the dashpot cover. The connecting rod and connecting rod bushing must be lubricated at least monthly or as conditions dictate with a waterproof, FDA approved grease such as Lubriko #CW-606 grease. Using a cartridge grease gun, pump grease into the grease fitting 2 full strokes of the grease lever. It is normal for grease to be forced out of the rod wiper (52). If the valve is operated infrequently, apply a thin film of grease to the exposed surfaces of the cylinder piston rod and connecting rod. Painting of the connecting or cylinder rod will void the warranty.

**WARNING:** For valves with Top Mounted Dashpots, DO NOT paint exposed surfaces of the connecting rod or the cylinder piston rod or damage will result to the hydraulic seals.

## OPTIONAL TOP DASHPOT (Cont'd)

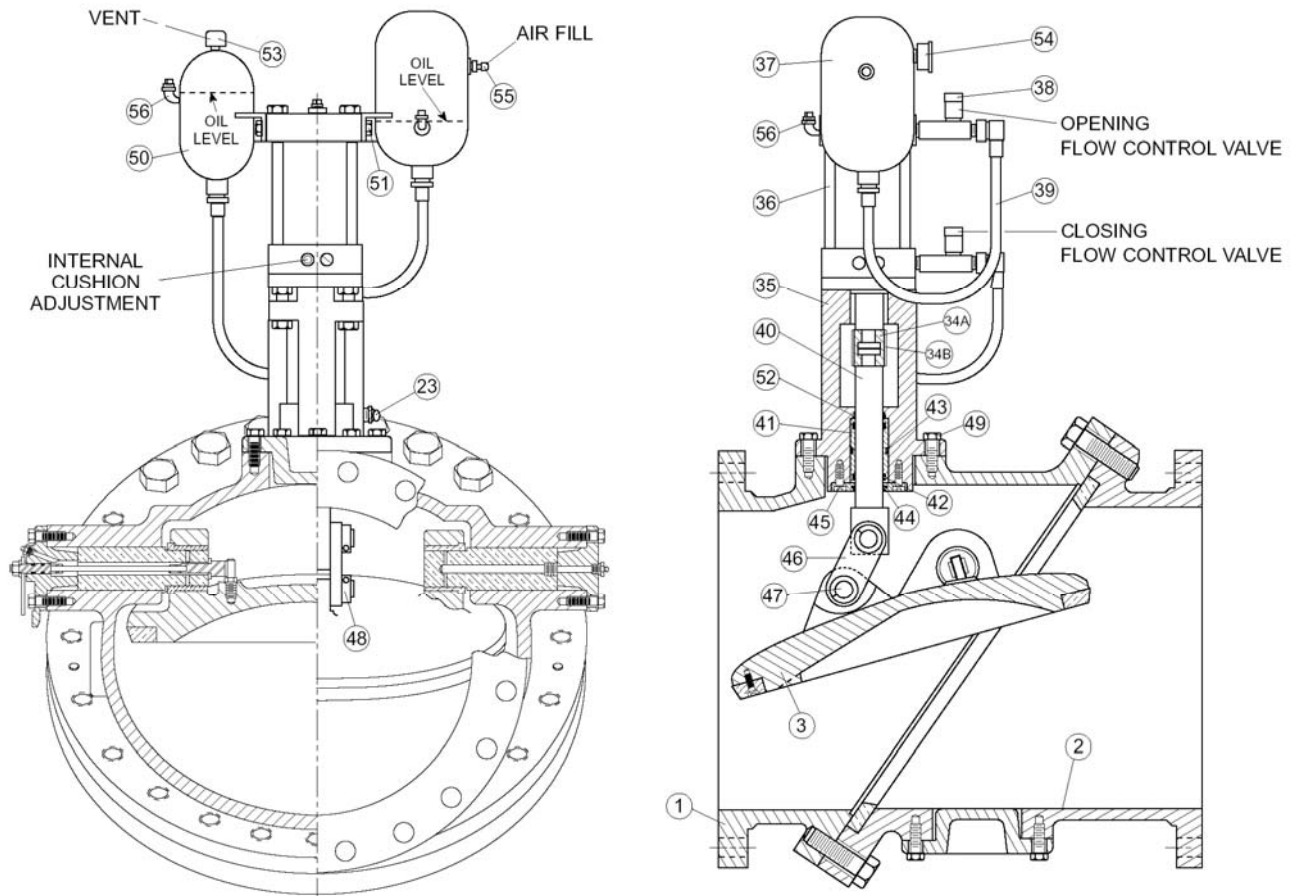
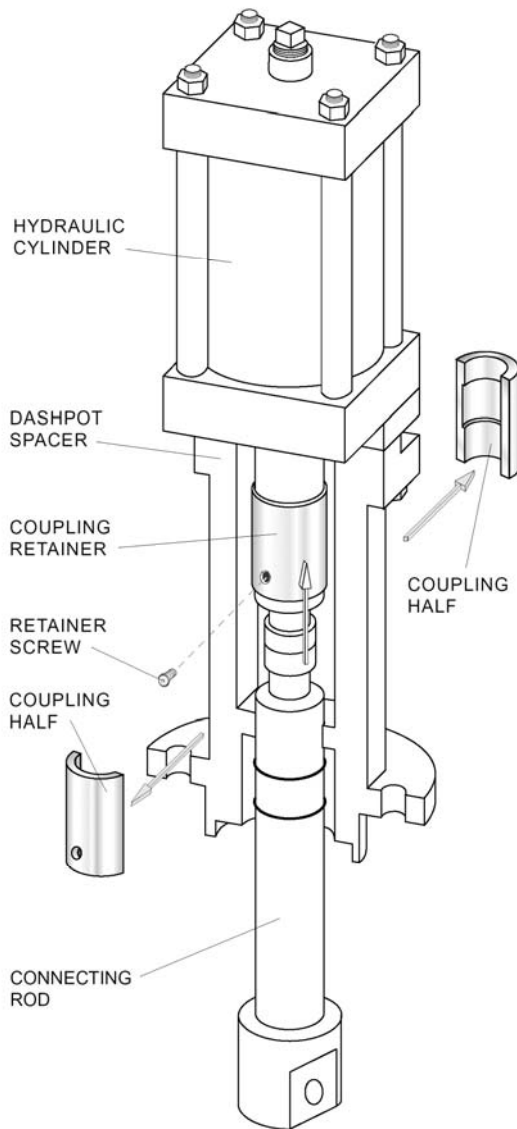

Figure 7. Top Mounted Oil Dashpot (TMOD) Construction

Part No.	Part Name	Material	Part No.	Part Name	Material
1	Pivot Body Half	Cast or Ductile Iron	44	Bushing Retainer Plate	Cast Iron
2	Seat Body Half	Cast or Ductile Iron	45	Retainer Plate Screw	Stainless Steel
3	Disc	Cast or Ductile Iron	46	Linkage	Stainless Steel
34A	Coupling	Stainless Steel	47	Linkage Pin	Stainless Steel
34B	Coupling Retainer	Stainless Steel	48	Linkage Pin Retainer	Stainless Steel
35	Dashpot Spacer	Cast Iron	49	Dashpot Spacer Bolts	Alloy Steel
36	Dashpot Cylinder	NFPA, Steel	50	Non-Pres. Reservoir	Stainless Steel
37	Pressurized Reservoir	Carbon Steel	51	Mounting Screws	Alloy Steel
38	Flow Control Valve	Brass	52*	Rod Wiper	Molythane
39	Dashpot piping	Steel and Rubber Hose	53	Breather/Filter	Steel, Plated
40	Connecting Rod	Stainless Steel	54*	Pressure Gauge	Brass
41	Spacer Bushing	Aluminum Bronze	55*	Air Inlet Valve	Stainless Steel
42*	Connecting Rod O-Ring	Buna-N	56	Oil Fill Port	Brass
43*	Bushing O-ring	Buna-N			

\*Recommended Spare Part

## OPTIONAL TOP DASHPOT (Cont'd)



**Figure 8. Quick Change Coupling**

The Quick Change Coupling provides for easy removal and maintenance of the dashpot assembly while the check valve is under pressure. The coupling also provides a self-aligning connection which prolongs the life of the seals and bushings in the cylinder and dashpot assembly.

The coupling is formed in two half-sections. The sections are joined together around the ends of the cylinder rod and the connecting rod and secured with an outer slip-type coupling retainer.

**TROUBLESHOOTING VALVE WITH TOP MOUNTED OIL DASHPOT:** The top mounted oil

dashpot is linked directly to the disc. Flow control valves (38) control the opening and closing speeds in the 5-30 second range. The last 10% of closure is also controlled by the cylinder cushion control.

1. Valve Does Not Close Fully: Check air pressure in reservoir; should be at least 20% of the water system pressure on the downstream side of the valve or 10 psig minimum. The pressure can be increased until the valve closes but the opening stroke may be reduced. Add grease to dashpot fitting (23). Open lower flow control valve (38) further to allow greater oil flow. Readjust flow control valve until slam is diminished. A differential pressure across of the disc of at least 50 psig is typical for dashpot valves. If the pressure is lower, the dashpot is probably not needed and may interfere with valve operation.
2. Valve Slams Closed: Dashpot should prevent slamming by controlling the valve closure. Throttle down the bottom flow control valve (38) to slow down valve closure. If problem persists, check oil level in unit per the Instruction Manual.
3. Valve Does Not Open: Open top flow control valve (38) fully counterclockwise. Check pressure differential across disc; upstream pressure must be greater than downstream pressure. Verify that downstream shutoff valve is open and there is no line blockage. Add grease to valve and dashpot grease fittings (23). Lower pressure on air tank (pressure should be 20% of water system pressure). Pressure can be temporarily reduced to 0 psig to assist in valve opening. Drain the pipe on both sides of the valve, remove inspection cover (13), and inspect disc ring (8) and seat ring (10) for damage or wedged debris. If debris is wedged in the valve, it may be necessary to jack open the disc with a hydraulic jack. See "Inspection of Valve" on page 1 of this guide for further information.
4. Noisy Operation or Vibration: Flow noise is normal. Loud flow noise similar to hammering may be cavitation from dropping high pressures across valve during opening and closing. Open flow control valves (38) to provide shorter operating times.
5. Pump Backspins: Valve is closing too slowly. Open bottom flow control valve (38) further. If surges in the pipeline result, surge relief devices on the pipeline probably need attention.
6. Pressure Surges: Throttle down bottom flow control valve (38) further to increase closing time.

## OPTIONAL TOP DASHPOT (Cont'd)

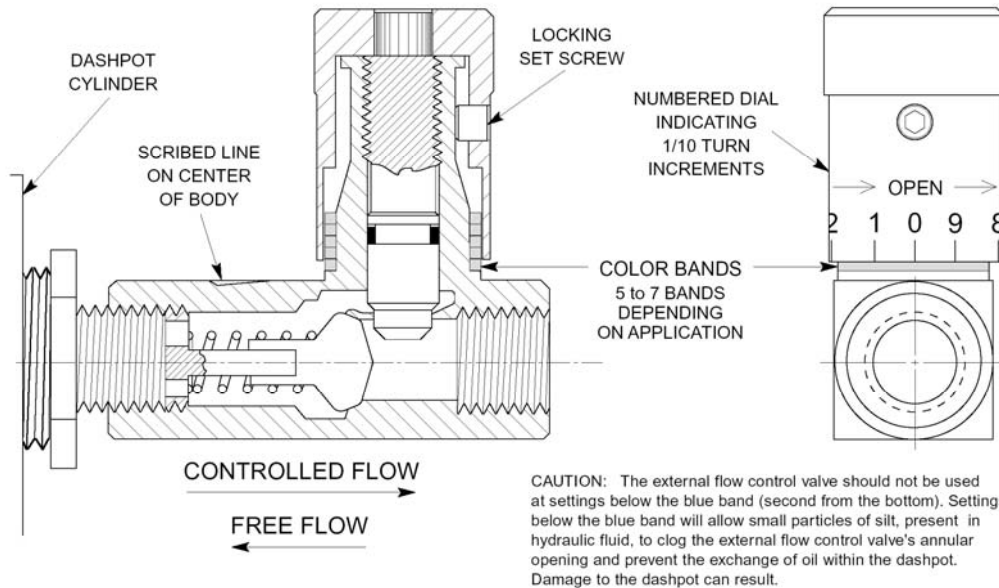

**Figure 9. Adjustment of Flow Control Valve**

7. Leakage of Oil: Wipe down controls and Identify location of leak. Tighten fittings where needed. Check that cylinder rod is clean with no paint or buildup. Cylinder seal kits can be used if cylinder leakage persists. An air tank pressure of at least 10 psi is needed to energize the rod seals.
8. Leakage of Water Through Dashpot: Replace seals (42) and (43) in bushing assembly.

**FLOW CONTROL VALVE ADJUSTMENT:** Flow control valves are specialized needle valves that allow free flow in one direction and controlled flow in the other direction. They are used to control the flow out of hydraulic cylinders. Hence, the "Controlled Flow" arrow marked on the valve must point away from the cylinder.

The flow control valve has color-coded bands and a numbered dial that allows the operator to make fine adjustments to the valve operating speed. Turning the numbered dial clockwise will close the flow control valve. The exposed color bands just below the bottom of the dial indicate the flow control

position. The red band on the bottom represents the valve's full open position. The flow control valve can be adjusted in increments of 1/10 of a turn by aligning the numbers (0 through 9) on the dial, with the scribed line on the flow control valve body. One full revolution of the knob will expose or remove a color band. Do not be used at settings below the blue band or clogging may occur. After all adjustments are made, the set screw should be locked into place to prevent accidental changes in the flow control valve setting.

**CAUTION:** Flow control valves should not be used at settings below the blue band (second from the bottom). Lower settings will allow small particles of silt present in the hydraulic fluid to clog the valve and cause the BMOD to bind and result in damage to the valve or dashpot.

## OPTIONAL BYPASS PIPING

DESCRIPTION: Bypass piping can be factory installed on one or both sides of the valve as shown in Figure 10. The bypass piping include a ball valve

so that water can be allowed to flow past the closed check valve to drain the downstream piping or wash the pump suction piping or screens. The bypass ball valves should normally be kept in the closed position.

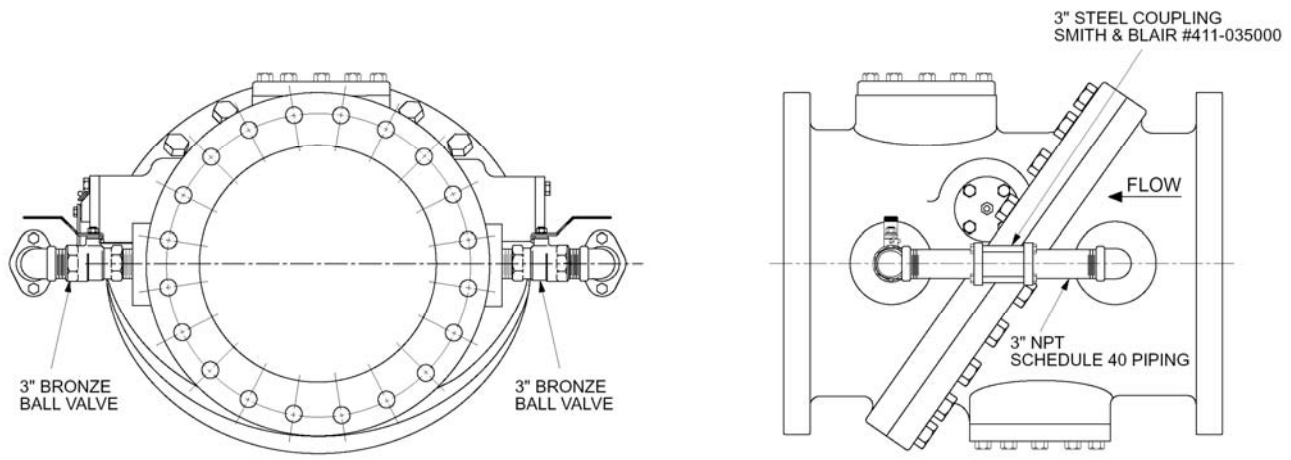

Figure 10. TDCV Bypass Piping

## PARTS AND SERVICE

Parts and service are available from your local representative or the factory. Make note of the Valve Size and Model Number located on the valve nameplate and contact:

A sales representative will quote prices for parts or arrange for service as needed.

Val-Matic Valve and Manufacturing Corp.  
905 Riverside Drive  
Elmhurst, IL 60126  
Phone: (630) 941-7600  
Fax: (630) 941-8042  
www.valmatic.com

### LIMITED WARRANTY

All products are warranted to be free of defects in material and workmanship for a period of one year from the date of shipment, subject to the limitations below.

If the purchaser believes a product is defective, the purchaser shall: (a) Notify the manufacturer, state the alleged defect and request permission to return the product; (b) if permission is given, return the product with transportation prepaid. If the product is accepted for return and found to be defective, the manufacturer will, at his discretion, either repair or replace the product, f.o.b. factory, within 60 days of receipt, or refund the purchase price. Other than to repair, replace or refund as described above, purchaser agrees that manufacturer shall not be liable for any loss, costs, expenses or damages of any kind arising out of the product, its use, installation or replacement, labeling, instructions, information or technical data of any kind, description of product use, sample or model, warnings or lack of any of the foregoing. NO OTHER WARRANTIES, WRITTEN OR ORAL, EXPRESS OR IMPLIED, INCLUDING THE WARRANTIES OF FITNESS FOR A PARTICULAR PURPOSE AND MERCHANTABILITY, ARE MADE OR AUTHORIZED. NO AFFIRMATION OF FACT, PROMISE, DESCRIPTION OF PRODUCT OF USE OR SAMPLE OR MODEL SHALL CREATE ANY WARRANTY FROM MANUFACTURER, UNLESS SIGNED BY THE PRESIDENT OF THE MANUFACTURER. These products are not manufactured, sold or intended for personal, family or household purposes.