

Val-Matic® 4"-20" Surge Suppression Air/Vacuum Valve

Operation, Maintenance and Installation Manual

INTRODUCTION	1
RECEIVING AND STORAGE.....	1
DESCRIPTION OF OPERATION	1
INSTALLATION.....	2
VALVE CONSTRUCTION	2
MAINTENANCE	3
TROUBLESHOOTING	3
DISASSEMBLY	3
REASSEMBLY	4
REGULATED EXHAUST DEVICE	4
PARTS & SERVICE	5
WARRANTY	6



VALVE AND MANUFACTURING CORP.

905 Riverside Dr. • Elmhurst, IL 60126
Phone (630) 941-7600 • Fax (630) 941-8042

VAL-MATIC'S 4"-20" SURGE SUPPRESSION AIR/VACUUM VALVE

INTRODUCTION

This manual will provide you with the information to properly install and maintain the valve to ensure a long service life. The Surge Suppression Air/Vacuum Valve has been designed with stainless steel trim to give years of trouble free operation. The valve is typically mounted on a pipeline at the high points or large changes in grade.

The valve will exhaust large quantities of air in a controlled manner during system start-up and allow air to re-enter the line rapidly upon system shut down or after a power failure. The valves are needed to maintain pipeline efficiency while providing protection from adverse pressure condition. The Size, Maximum Working Pressure, and Model No. are stamped on the nameplate for reference.

NOTE: While Air/Vacuum Valves will exhaust large quantities of air upon start-up, they will not continuously release air during system operation. For that function, Air Release Valves are required.

Also, this valve is not intended for fluids containing suspended solids such as wastewater. For wastewater and other high turbidity applications, use Val-Matic Series 300 Wastewater Air/Vacuum Valves.

CAUTION: This valve is not intended for fluids containing suspended solids or hazardous gases.

RECEIVING AND STORAGE

Inspect valves upon receipt for damage in shipment. Unload all valves carefully to the ground without dropping. Valves should remain crated, clean and dry until installed to prevent weather related damage. For long-term storage, greater than six months, the rubber surfaces of the seats should be coated with a thin film of FDA approved grease. Do not expose seat to sunlight or ozone for any extended period.

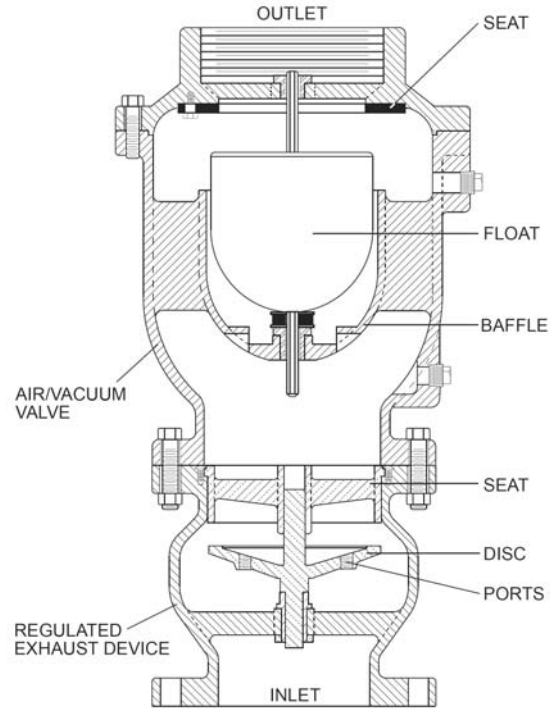

Figure 1. 4"-20" Air/Vacuum Valve

DESCRIPTION OF OPERATION

The Surge Suppression Air/Vacuum Valve is designed to exhaust large quantities of air in a controlled manner during pump or system startup and allow air to reenter the line or pump column upon pump shutdown or line break. During startup, air enters the bottom of the valve and is exhausted through the regulated exhaust device and air valve. If the exhaust rate is high, the disc will close and the airflow will be throttled through the adjustable ports in the disc.

After the air is exhausted, water enters the valve and causes the float to rise and seal the outlet port. The valve will remain closed until system pressure drops to near zero pressure. It will open during shutdown to reduce the possibility of a vacuum forming and allow rapid drainage of the line when system maintenance is required.

INSTALLATION

The installation of the valve is important for its proper operation. The valves must be installed at the system high points in the vertical position with the inlet down. For pipeline service, a vault with freeze protection, adequate screened venting, and drainage should be provided. During closure, some fluid discharge will occur so vent lines should extend to an open drain for in-plant installations. A shutoff valve should be installed below the valve in the event servicing is required. A spool piece is required when mating to a wafer butterfly valve.

CAUTION: Remove packing from outlet and install valve with "INLET" port down or leakage will occur.

FLANGED ENDS: Flanged valves should be mated with flat-faced pipe flanges equipped with resilient gaskets. When ring gaskets are used, the bolt material shall be ASTM A307 Grade B or SAE Grade 2 carbon steel.

Lower the valve over the mating flange using slings or chains around the valve body. Lubricate the flange bolts or studs and insert them around the flange. Lightly turn bolts until gaps are eliminated. The tightening of the bolts should be done in graduated steps using the crossover tightening method. Recommended lubricated torque values, for use with resilient gaskets (75 durometer), are given in Table 1.

If leakage occurs, allow gaskets to absorb fluid and check the bolt torque and leakage after 24 hours. Do not exceed bolt rating or crush gasket more than 50% of its thickness.

CAUTION: The use of raised-face flanges or excessive bolt torque may damage valve flanges.

<u>Valve Size</u> (in)	<u>Bolt Dia</u> (in)	<u>Recom. Torque</u> (ft-lbs)	<u>Max. Torque</u> (ft-lbs)
4	5/8	30	90
6	3/4	30	150
8	3/4	40	150
10	7/8	45	205
12	7/8	45	205
14	1	80	300
16	1	90	300
20	1 1/8	120	425

Table 1. Flange Bolt Torques

VALVE CONSTRUCTION

The standard Air/Vacuum Valve body and cover are cast iron. See specific Materials List submitted for the order if other than standard cast iron construction. The internal metal components are stainless steel. The float (5) is the only moving part assuring long life with minimal maintenance. The general details of construction are illustrated in Figure 2. The body (1) is flanged for connection to the pipeline. The resilient seat (4) is retained in the cast cover (2). An optional hood is available.

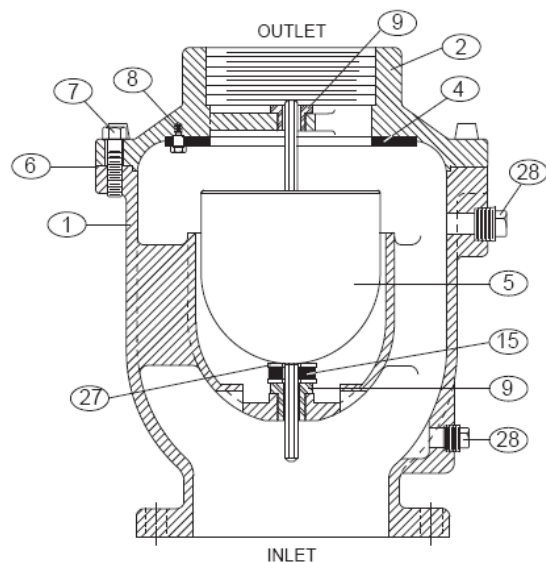

Figure 2. 4"-20" Air/Vacuum Valve

Item	Description	Material
1	Body	Cast Iron
2	Cover	Cast Iron
4	Seat*	Buna-N
5	Float*	Stainless Steel
6	Gasket*	Non-Asbestos
7	Cover Bolt	Alloy Steel
8	Retaining Screw	Stainless Steel
9	Guide Bushing*	Stainless Steel
15	Cushion*	Buna-N
23	Hood Assembly (optional)	Iron, Steel
27	Washer* (8"-20" valves)	Stainless steel
28	Pipe Plug	Malleable Iron

*Recommended Spare Part

Table 2. Air/Vacuum Valve Parts List

MAINTENANCE

The Air/Vacuum Valve requires no scheduled lubrication or maintenance.

INSPECTION: Periodic inspection for leakage can be performed. A manual drain valve can be installed in the lower drain plug to perform this operation as shown in figure 3.

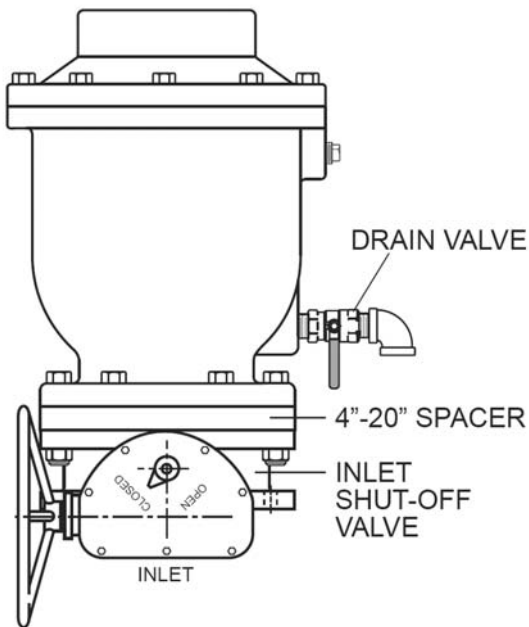

Figure 3. Inspection Piping

To verify valve function, refer to Figure 3 and:

1. Crack open the drain valve until any air trapped in the valve is relieved. Close the drain and the inlet shutoff valve.
2. Open the drain valve to allow the fluid in the valve to drain. It may be necessary to apply a downward force on the float to unseat the valve.
3. Close the drain valve.
4. Slowly open the inlet shutoff valve to fill the valve with water. Observe the seating action and verify that the valve closes without leakage.
5. If leakage occurs, the valve should be removed and inspected for wear or possible damage from foreign matter.

TROUBLESHOOTING

Several problems and solutions are presented below to assist you in troubleshooting the valve assembly in an efficient manner.

1. Leakage at Bottom Connection: Tighten valve flanged connection. If leak persists, remove valve and replace gasket.
2. Leakage at Cover: Tighten bolts, replace gasket.
3. Valve Leaks when Closed: Inspect seat for damage and replace.

DISSASSEMBLY

The valve can be disassembled without removing it from the pipeline. Or for convenience, the valve can be removed from the line. All work on the valve should be performed by a skilled mechanic with proper tools. Refer to Figure 2.

WARNING: The valve must be drained before removing the cover or pressure may be released causing injury.

1. Close inlet shutoff valve. Open drain valve or remove drain plug. Remove hood if needed.
2. Remove the cover bolts (7) on the top cover. Pry cover (2) loose and lift off valve body.
3. Remove retainer bolts (8) and inspect seat for cracks in rubber or wear in sealing surface.

4. Lift float (5) from body. Turn guide bushing (9) to remove it from body (1).
5. Clean and inspect parts. Note: some floats contain sand for extra weight; if water is detected, replace float. Replace worn parts as necessary and lubricate parts with FDA grease. Remove all foreign matter from body and cover.

REASSEMBLY

All parts must be cleaned and gasket surfaces should be cleaned with a stiff wire brush in the direction of the serrations or machine marks. Worn parts, gaskets and seals should be replaced during reassembly.

1. Apply thread sealant Loctite 680 to guide bushing threads (9) and thread bushing into body (1).
2. Lay seat (4) over inverted cover with flat surface directed toward cover. Fasten to cover with screws (8). Tighten fasteners per Table 3.
3. Install float (5) through bushing (9).
4. Apply a gasket compound such as Garlock 101-S to both sides of gasket. Lay cover gasket (6) and cover (2) over bolt holes in body (1).
5. Insert lubricated bolts (7) and tighten to the torques listed in Table 3.

<u>Size</u>	<u>Torque (ft-lbs)</u>
1/4"	6
5/16"	11
3/8"	19
7/16"	30
1/2"	45
5/8"	93
3/4"	150
7/8"	202

Table 3. Valve Bolts Torques

REGULATED EXHAUST DEVICE

DESCRIPTION OF OPERATION: Surge Suppression Air/Vacuum valves are equipped with a regulated exhaust device on the inlet port as shown in Figure 4. The purpose of the device is close during high air exhaust conditions to prevent columns of water from rejoining or striking the air valve rapidly during critical operation such as after a sudden pipeline flow stoppage from a power failure.

The regulated exhaust device is normally open and allows **unrestricted flow** of air in but controlled flow out of the air/vacuum valve. The passage of air is throttled through small ports in the disc, which reduces the possibility of shocks and water hammer in the pipeline.

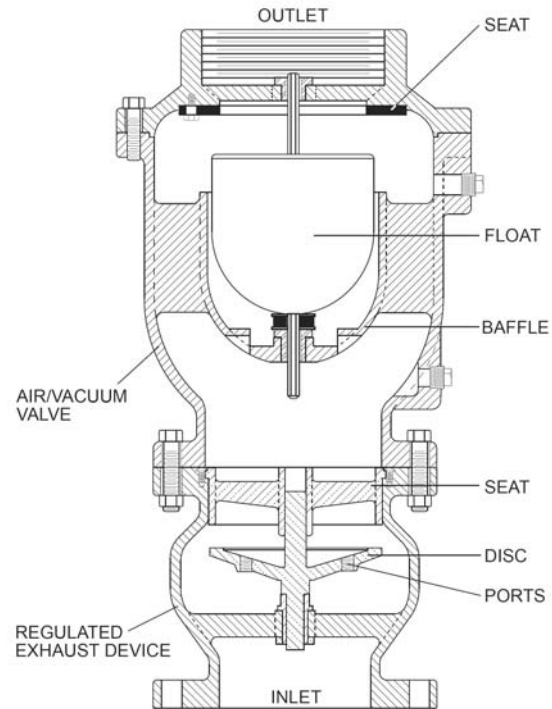

Figure 4. Regulated Exhaust Device

VALVE CONSTRUCTION: The standard body is cast iron with a bronze disc. See specific Materials List submitted for the order if other than standard cast iron construction. The general details of construction are illustrated in Figure 5. The body (1) is flanged for connection to the pipeline. See page 2 for installation to the pipeline.

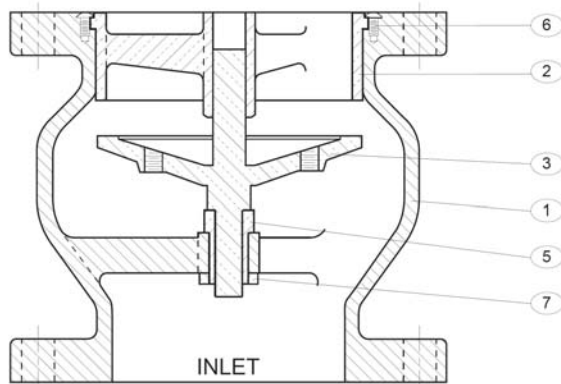

Figure 5. Regulated Exhaust Device

Item	Description	Material
1	Body	Cast Iron
2	Seat	Bronze
3	Disc	Bronze
5	Bushing*	Brass
6	Seat Ret. Screw*	Stainless Steel
7	Retainer Nut*	Brass

*Recommended Spare Part

Table 4. Regulated Exhaust Device Parts List

MAINTENANCE: The regulated exhaust device requires no scheduled lubrication or maintenance. The flow characteristics of the valve are adjustable. If the float in the air valve slams shut due to the flow of the air or water, close off some of the tapped holes of the disc with standard pipe plugs until the desired characteristic is achieved.

DISASSEMBLY: The valve can be disassembled without removing it from the pipeline. Or for convenience, the valve can be removed from the line. All work on the valve should be performed by a skilled mechanic with proper tools.

WARNING: The valve must be drained before removing the cover or pressure may be released causing injury.

1. Close main isolation valve. Drain air/vacuum valve with drain port.
2. Unbolt air/vacuum valve and remove from top of Regulated Exhaust Device. Replace gasket if damaged.
3. Remove small seat fasteners on flange face.
4. Lift seat and disc from the valve body.
5. Clean and inspect parts for wear.

Replace parts if worn or damaged. During reassembly, tighten flange bolts with the "Max. Torque" values given in Table 1.

PARTS AND SERVICE

Parts and service are available from your local representative or the factory. Make note of the valve Size and Model No. located on the valve nameplate and contact:

Val-Matic Valve and Mfg. Corp.
 905 Riverside Drive
 Elmhurst, IL 60126
 PH: 630 / 941-7600
 FAX: 630 / 941-8042

A sales representative will quote prices for parts or arrange for service as needed.

LIMITED WARRANTY

All products are warranted to be free of defects in material and workmanship for a period of one year from the date of shipment, subject to the limitations below.

If the purchaser believes a product is defective, the purchaser shall: (a) Notify the manufacturer, state the alleged defect and request permission to return the product; (b) if permission is given, return the product with transportation prepaid. If the product is accepted for return and found to be defective, the manufacturer will, at his discretion, either repair or replace the product, f.o.b. factory, within 60 days of receipt, or refund the purchase price. Other than to repair, replace or refund as described above, purchaser agrees that manufacturer shall not be liable for any loss, costs, expenses or damages of any kind arising out of the product, its use, installation or replacement, labeling, instructions, information or technical data of any kind, description of product use, sample or model, warnings or lack of any of the foregoing. NO OTHER WARRANTIES, WRITTEN OR ORAL, EXPRESS OR IMPLIED, INCLUDING THE WARRANTIES OF FITNESS FOR A PARTICULAR PURPOSE AND MERCHANTABILITY, ARE MADE OR AUTHORIZED. NO AFFIRMATION OF FACT, PROMISE, DESCRIPTION OF PRODUCT OF USE OR SAMPLE OR MODEL SHALL CREATE ANY WARRANTY FROM MANUFACTURER, UNLESS SIGNED BY THE PRESIDENT OF THE MANUFACTURER. These products are not manufactured, sold or intended for personal, family or household purposes.



VALVE AND MANUFACTURING CORP.

905 Riverside Dr. • Elmhurst, IL 60126
Phone (630) 941-7600 • Fax (630) 941-8042