

14” and Larger Wafer and Lug Style Dual Disc[®] Check Valve

Operation, Maintenance and Installation Manual

INTRODUCTION.....	1
RECEIVING AND STORAGE.....	1
DESCRIPTION OF OPERATION.....	1
INSTALLATION.....	2
VALVE CONSTRUCTION.....	3
MAINTENANCE.....	5
TROUBLESHOOTING.....	5
DISASSEMBLY.....	5
REASSEMBLY.....	5
PARTS AND SERVICE.....	6
WARRANTY.....	6



VAL-MATIC[®] VALVE AND MANUFACTURING CORP.

905 Riverside Dr. • Elmhurst, IL 60126
Phone (630) 941-7600 • Fax (630) 941-8042
www.valmatic.com

14"-60" WAFER STYLE DUAL DISC® CHECK VALVE OPERATION, MAINTENANCE AND INSTALLATION

INTRODUCTION

This manual will provide you with the information to properly install and maintain the valve to ensure a long service life. The Dual Disc® Check Valve is ruggedly constructed with bronze or stainless steel trim to give years of trouble free operation. The valve should be installed in horizontal or vertical flow up pipes carrying clean water. The valves can be equipped with special springs for operation in blower air service (Series 8900).

The Dual Disc® Check Valve is designed to open fully to provide flow in the forward direction and close rapidly upon flow reversal. The valves are used to prevent reverse flow through pumps or in piping systems. The size, cold working pressure, and model number are stamped on the nameplate for reference.

This valve is not intended for fluids containing suspended solids such as wastewater. For wastewater and other high turbidity applications, use Val-Matic Series 500 Swing-Flex® Check Valves.

CAUTION
This valve is not intended for fluids containing suspended solids or hazardous fluids

RECEIVING AND STORAGE

Inspect valves upon receipt for damage in shipment. Unload all valves carefully to the ground without dropping. When lifting, the valve should be secured by the body and never lifted by the bronze or stainless steel trim. Threaded holes are provided on the top of the valves for the insertion of an eye bolt.

The valves should remain crated, clean and dry until installed to prevent weather related damage. For long term storage greater than six months, the rubber surfaces of the seat (when provided) should be coated with a thin film of FDA approved grease. Do not expose rubber seat to sunlight or ozone for any extended period.

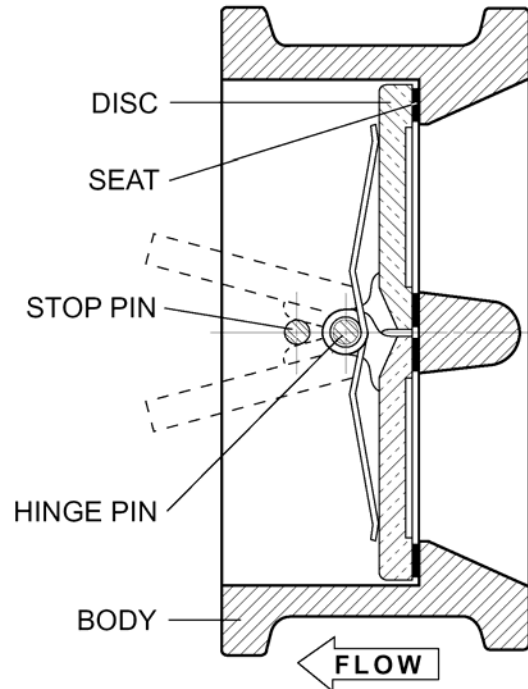

FIGURE 1. DUAL DISC® CHECK VALVE

DESCRIPTION OF OPERATION

The Dual Disc® Check Valve is designed to prevent reverse flow automatically. On pump start-up, the flow of water enters the valve from the seat end (right side in Figure 1) and forces the two discs open until they strike the disc stop pin. On pump shut-down, the torsion spring closes the disc before a flow reversal takes place.

The valve body is supplied with either compact wafer ends as shown in Figure 1 for installation between mating flanges or in a lug wafer configuration where the flanges are tapped to accept flange bolts.

The only moving parts in the valve are the discs and spring. The discs and spring are guided in the body with a hinge pin and a full open disc stop pin. The pins are restrained in the body by stabilization spheres to prevent vibration. The valve also has a resilient seat for drop tight shut off.

INSTALLATION

The installation of the valve is important for its proper operation. The **flow arrow** on the valve body or nameplate must point in the direction of flow when the system is in operation. The valve can be installed in horizontal or vertical lines with the flow up. Valves for air service (Series 8900) require special springs to allow full valve opening.

The valve should be installed between standard flanges per ANSI B16.1 or AWWA C207. The gasket can be rubber or compressed fiber.

Three diameters of straight pipe upstream of the valve are recommended to prevent turbulent flow streams through the valve, which can cause vibration and wear.

When mating the check valve with butterfly isolation valves, the isolation valve must be installed at least one diameter downstream of the check valve. The check valve discs extend beyond the downstream flange face and may interfere with the operation of adjacent valves. A short run of pipe or spacer is needed between the check valve and the isolation valve.

LUG WAFER ENDS: Lug wafer valves should be mated with flat-faced pipe flanges equipped with resilient gaskets.

WAFER ENDS: Wafer valves should be mated with flat-faced pipe flanges equipped with resilient ring gaskets and full length studs.

INSTALLATION: Lower valve between mating flange using slings or chains around the valve body. The valves have a tapped hole for insertion of a lifting eye if needed. Lubricate the flange bolts or studs and insert them around the flange. Lightly turn bolts or nuts until gaps are eliminated. The tightening of the bolts should then be done in graduated steps using the cross-over tightening method. Recommended lubricated torques for use with resilient gaskets (75 durometer) are given in Table 1.

If leakage occurs, allow gaskets to absorb fluid and check torque and leakage after 24 hours. Do not exceed bolt rating or crush gasket more than 50 per cent of its thickness.

125# Flange Data			250# Flange Data		
Valve Size (in)	Bolt Dia. (in)	Bolt Torque (ft-lbs)	Valve Size (in)	Bolt Dia. (in)	Bolt Torque (ft-lbs)
14	1	80-250	14	1 1/8	140-450
16	1	90-300	16	1 1/4	180-600
18	1 1/8	100-350	18	1 1/4	190-600
20	1 1/8	120-450	20	1 1/4	220-600
24	1 1/4	150-500	24	1 1/2	350-900
30	1 1/4	180-600	30	1 3/4	500-1200
36	1 1/2	250-700	36	2	700-1500
42	1 1/2	300-800	42	2	800-1600
48	1 1/2	400-900	48	2	900-1800
54	1 3/4	500-1200			
60	1 3/4	700-1500			

CAUTION
The use of excessive bolt torque may damage valve.

VALVE CONSTRUCTION (14" - 30")

The standard check valve body (1) is constructed of cast iron. See the specific Materials List submitted for the order if other than standard iron construction. The internal metal components are bronze or stainless steel. The discs (2) and torsion spring (3) are the only moving parts and require no maintenance or lubrication. The general details of construction are illustrated in Figure 2.

The body (1) is either compact wafer style to fit between two pipe flanges or lug style for bolting to two pipe flanges. The resilient seat is bonded to the body and is not adjustable or replaceable in the field.

WARNING

Removal of mating flanges without draining the pipeline may cause injury or damage to the valve.

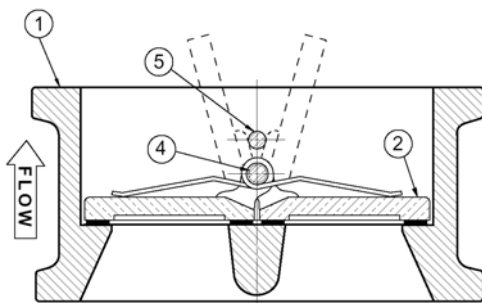
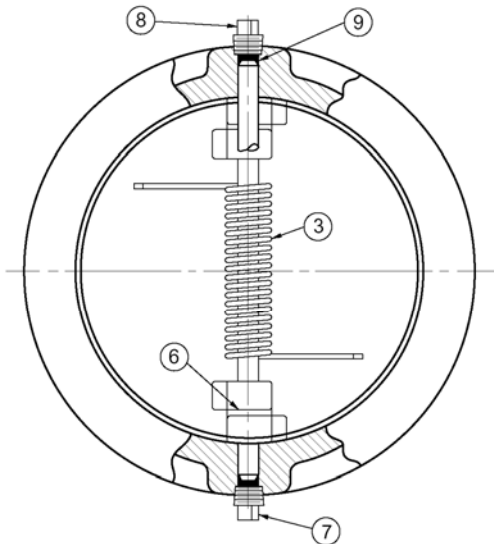

FIGURE 2. DUAL DISC® CHECK VALVE

Table 2. Check Valve Parts List		
Item	Description	Material
1	Body	Cast Iron
2	Disc	Bronze
3	Spring* (qty. 2 springs on 18" and larger)	Stainless Steel
4	Hinge Pin	Stainless Steel
4B	Shaft Collar (Item 4B on 36" and larger sizes)	Stainless Steel
5	Stop Pin	Stainless Steel
6	Bearing*	Stainless Steel
7	Hinge Pin Ret.*	Steel
8	Stop Pin Ret.*	Steel
9	Stab. Sphere*	Buna-N

* Recommended Spare Part

VALVE CONSTRUCTION (36"- 60")

The standard check valve body (1) is constructed of cast iron. See the specific Materials List submitted for the order if other than standard iron construction. The internal metal components are bronze or stainless steel. The discs (2) and torsion spring (3A and 3B) are the only moving parts and require no maintenance or lubrication. The general details of construction are illustrated in Figure 3.

The body (1) is either compact wafer style to fit between two pipe flanges or lug style for bolting to two pipe flanges. The resilient seat is bonded to the body and is not adjustable or replaceable in the field.

WARNING
Removal of mating flanges without draining the pipeline may cause injury or damage to the valve.

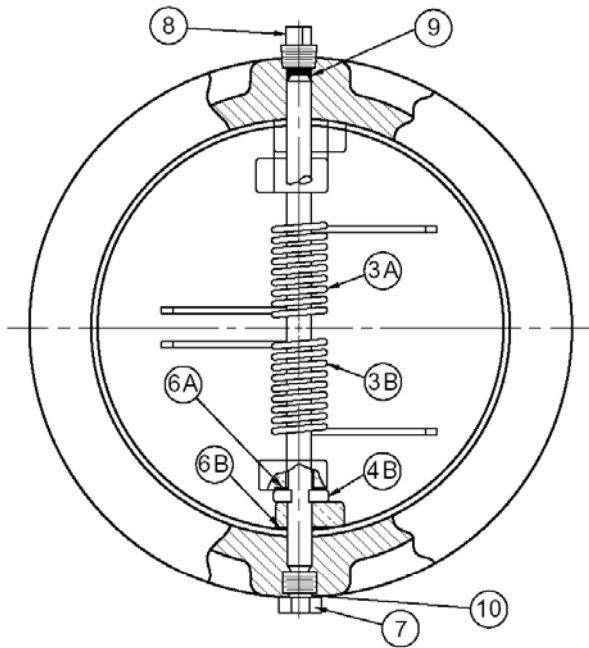

Table 3. Check Valve Parts List		
Item	Description	Material
1	Body	Cast Iron
2	Disc	Bronze
3A,3B	Spring*	Stainless Steel
4A	Hinge Pin	Stainless Steel
4B	Shaft Collar	Stainless Steel
5	Stop Pin	Stainless Steel
6A	Inner Bearing*	Stainless Steel
6B	Outer Bearing*	Stainless Steel
7	Hinge Pin Ret.*	Steel
8	Stop Pin Ret.*	Steel
9	Stab. Sphere*	Buna-N
10	O-Ring*	Buna-N

* Recommended Spare Part

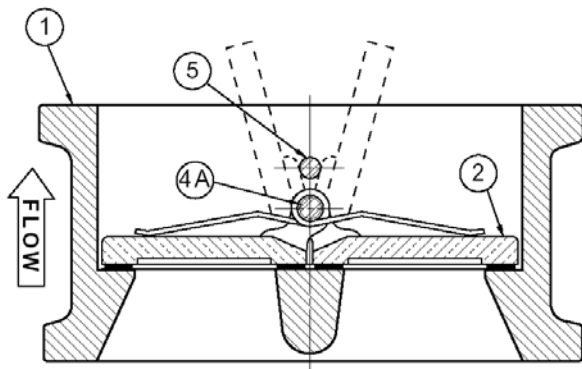

FIGURE 3. DUAL DISC® CHECK VALVE

MAINTENANCE

Dual Disc® Check Valves require no scheduled lubrication of maintenance.

INSPECTION: Periodic inspection for leakage can be performed by listening for leakage noise from the valve while the pump is shut down. If leakage is heard, drain the pipeline, remove the valve, and inspect the seating surfaces for wear or damage. If the resilient seat is damaged, replace the valve or return the valve to the factory for refurbishing.

TROUBLESHOOTING

Several problems and solutions are presented below to assist you in trouble shooting the valve assembly in an efficient manner.

- **Valve Chatters or Vibrates:** Verify that velocity is at least 4 feet per second (consult the factory for air service). A partially open valve will wear prematurely. Verify that there are three diameters of straight pipe upstream.
- **Valve Leakage:** Check gaskets and flange bolt torque for flange leakage. Drain line, remove valve, and inspect seating surfaces.
- **Valve Does Not Pass Flow:** Check flow arrow direction on valve body. Verify that downstream isolation valve is open and there is no line blockage downstream.
- **Valve Slams:** Remove valve and inspect spring. Heavier springs can be furnished for severe high-head applications. Consult factory if the valve is installed in a vertical pipe with the flow downward.

DISASSEMBLY

The valve should be removed from the pipeline for disassembly. All work on the valve should be performed by a skilled mechanic with proper tools. Refer to Figure 2.

WARNING

The line must be drained before removing the valve or pressure may be released causing injury.

1. Remove the valve from the pipeline. 10" and larger valves have threaded holes for insertion of an eye bolt. Lay valve on flat surface or bench with the flow arrow facing upwards.
2. Remove the threaded pin retainers (8) and the rubber spheres (9). 36" and larger valves have a thrust collar (4B) which must be removed prior to driving out the pins.

3. Drive out the pins (4 and 5) with a round bar or punch while pressing down on the spring (3) to prevent it from unwinding. Valve 18" and larger have 2 springs and require extreme care to prevent rapid recoiling of the spring during disassembly. Restrain the spring with boards and clamps during disassembly.
4. Lift discs (2) from body. Inspect pins and seating surfaces for wear. The shaft diameter is normally about 1/16" smaller in diameter than the hole in the disc lugs. Some minor dents and discoloration are normal. Wear areas in the resilient seat will cause leakage and require valve replacement or refurbishing at the factory.
5. Remove spring (3) and check for wear or cracks.
6. Remove bearings (6) and inspect for wear.

REASSEMBLY

All parts must be clean and the gasket surfaces should be cleaned with a stiff wire brush in the direction of the serrations or machine marks. Worn parts, gaskets, and seals should be replaced during reassembly.

1. Lay body on flat surface with arrow facing upwards. Carefully place the two discs with the machined sealing surfaces down on the body sealing surface. Align the disc lugs with the pin holes in the body.
2. Insert the disc hinge pin into the hole on one side of the body, but not through the disc lugs. Install a thrust bearing (6) between the inside diameter of the body and the disc lug. Push the disc hinge pin further to engage the first disc lug.
3. Install the second thrust bearing (6) between the first and second disc lugs and push the pin further to engage the second disc lug.
4. While holding the torsion spring (3) with one of the ends facing you, wind the rear tab 180 degrees in a clockwise direction and then press the spring between the two sets of disc lugs. Engage the pin further to retain the spring and the third disc lug. The legs of the spring should apply a downward force on the discs.

NOTE: 18" and larger valves have 2 springs and require extreme care to prevent rapid recoiling of the springs. Restrain the spring during assembly with boards and clamps.

REASSEMBLY (Continued)

5. While pushing the pin further, install the third thrust bearing (6) and the fourth disc lug, and the fourth thrust bearing (6). The pin should now be centered in the body and the disc should rotate without binding.
6. Insert the disc stop pin (5) into the holes in the body.
7. Insert a sphere (9) into each of the four pin holes. 48" and larger valves have rubber washers instead of spheres.
8. Place a small amount of pipe thread sealant such as Loctite PST on the retainer plugs (7 and 8) and tighten into place. 48" and larger valves will have o-rings for 2 of the plugs instead of tapered threads.
9. Stand the valve on its edge with the pins vertical and verify smooth operation of the valve before installation into the pipeline. Apply a light coat of silicone grease on the rubber seat for air service valves (Series 8900).

PARTS AND SERVICE

Parts and service are available from your local representative or the factory. Make note of the Valve Size and Model Number located on the valve nameplate and contact:

Val-Matic Valve and Manufacturing Corp.
905 Riverside Drive
Elmhurst, IL 60126
Phone: (630) 941-7600
Fax: (630) 941-8042
www.valmatic.com

A sales representative will quote prices for parts or arrange for service as needed.

LIMITED WARRANTY

All products are warranted to be free of defects in material and workmanship for a period of one year from the date of shipment, subject to the limitations below.

If the purchaser believes a product is defective, the purchaser shall: (a) Notify the manufacturer, state the alleged defect and request permission to return the product; (b) if permission is given, return the product with transportation prepaid. If the product is accepted for return and found to be defective, the manufacturer will, at his discretion, either repair or replace the product, f.o.b. factory, within 60 days of receipt, or refund the purchase price. Other than to repair, replace or refund as described above, purchaser agrees that manufacturer shall not be liable for any loss, costs, expenses or damages of any kind arising out of the product, its use, installation or replacement, labeling, instructions, information or technical data of any kind, description of product use, sample or model, warnings or lack of any of the foregoing. NO OTHER WARRANTIES, WRITTEN OR ORAL, EXPRESS OR IMPLIED, INCLUDING THE WARRANTIES OF FITNESS FOR A PARTICULAR PURPOSE AND MERCHANTABILITY, ARE MADE OR AUTHORIZED. NO AFFIRMATION OF FACT, PROMISE, DESCRIPTION OF PRODUCT OF USE OR SAMPLE OR MODEL SHALL CREATE ANY WARRANTY FROM MANUFACTURER, UNLESS SIGNED BY THE PRESIDENT OF THE MANUFACTURER. These products are not manufactured, sold or intended for personal, family or household purposes.

The logo for Val-Matic, featuring the word "VAL-MATIC" in a bold, stylized font with a registered trademark symbol. The letters are black and have a slight shadow effect.

VAL-MATIC® VALVE AND MANUFACTURING CORP.

905 Riverside Dr. • Elmhurst, IL 60126
Phone (630) 941-7600 • Fax (630) 941-8042
www.valmatic.com