

# Air Release Valve

## Series 38, 45, 50

### (Compound Lever Type)

## Operation, Maintenance and Installation Manual

INTRODUCTION.....	1
RECEIVING AND STORAGE .....	1
DESCRIPTION OF OPERATION.....	1
INSTALLATION .....	2
VALVE CONSTRUCTION.....	2
MAINTENANCE .....	3
TROUBLESHOOTING .....	3
DISASSEMBLY .....	3
REASSEMBLY .....	4
PARTS & SERVICE .....	4
WARRANTY .....	5



VAL-MATIC® VALVE AND MANUFACTURING CORP.

---

905 Riverside Dr. • Elmhurst, IL 60126  
Phone (630) 941-7600 • Fax (630) 941-8042  
[www.valmatic.com](http://www.valmatic.com)

# VAL-MATIC'S AIR RELEASE VALVE (Compound Lever Type) OPERATION, MAINTENANCE AND INSTALLATION

## INTRODUCTION

This manual will provide you with the information to properly install and maintain the valve to ensure a long service life. The Air Release Valve has been designed with stainless steel trim to give years of trouble-free operation. The Air Release Valve is typically mounted at the high points in a piping system to automatically remove pockets of air as they accumulate. The valve can also be used to slowly release air in tanks and pump casings.

**Note:** This valve is not intended for fluids containing suspended solids such as wastewater. For wastewater and other high turbidity applications, use Val-Matic Series 48A & 49A Sewage Air Release Valves.

### **CAUTION**

**This valve is not intended for fuel service or fluids containing suspended solids.**

The valve is a float-operated, resilient-seated valve designed to handle clean fluids. The Maximum Working Pressure and Model No. are stamped on the nameplate for reference.

**Note:** Low Durometer seats are available for low pressure applications.

## RECEIVING AND STORAGE

Inspect valves upon receipt for damage in shipment. Handle all valves carefully without dropping. Valves should remain boxed, clean and dry until installed to prevent weather related damage. For long term storage greater than six months, the valve must remain in the box and stored indoors. Do not expose valve to sunlight or ozone for any extended period.

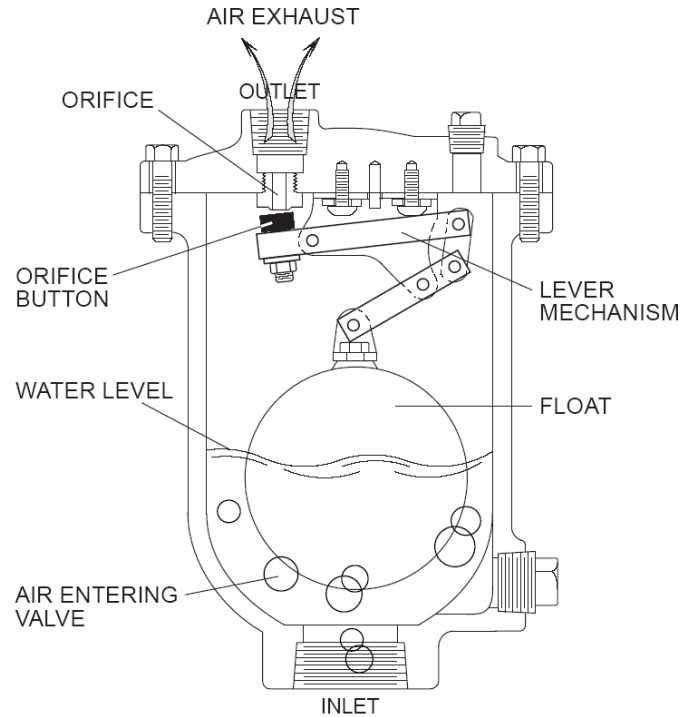

**FIGURE 1. Compound Lever AIR RELEASE VALVE**

## DESCRIPTION OF OPERATION

The Air Release Valve is designed to automatically remove air pockets at the high points in a piping system. The valve, as shipped, is a normally open valve and will slowly vent air through the top orifice. As fluid enters the valve, the float will rise, closing the orifice. As air accumulates in the piping system and enters the valve, the float drops allowing the venting orifice to open.

The lever mechanism provides mechanical advantage for the float. During system operation, the pipeline pressure exerts a strong upward force on the sealing component, the orifice button. The lever mechanism magnifies the weight of the float so that the orifice will open under high pipeline pressures. Additional ports are provided for flushing, testing and draining purposes.

## INSTALLATION

The installation of the valve is important for its proper operation. Valves must be installed at the system high points in the vertical position with the inlet down. For pipeline service, a vault with freeze protection, adequate screened venting, and drainage should be provided. During closure, some fluid discharge will occur so vent lines should extend to an open drain area in plant service. A shut-off valve should be installed below the valve in the event servicing is required.

**CAUTION**  
Install valve with "INLET" port down or leakage will occur.

## VALVE CONSTRUCTION

The standard Air Release Valve body and cover are cast iron. See the specific Materials List submitted for the order if other than standard cast iron construction. All internal components are stainless steel with the exception of the orifice button which is resilient. The general details of construction are illustrated in Figure 2. The body (1) is threaded for connection to the pipeline. The seat (4) is threaded into the cast cover (2).

ITEM	DESCRIPTION	MATERIAL
1	Body	Cast Iron
2	Cover	Cast Iron
3	Lever Frame*	Stainless Steel
4	Seat*	Stainless Steel
5	Float*	Stainless Steel
6	Gasket*	Non-Asbestos
7	Cover Bolt	Alloy Steel
8	Retaining Screw*	Stainless Steel
10	Float Arm*	Stainless Steel
11	Orifice Button*	Buna-N
12	Pivot Pin*	Stainless Steel
13	Retaining Ring*	Stainless Steel
14	Pipe Plug	Iron
17	Float Retainer*	Stainless Steel
18	Lock Nut*	Stainless Steel
19	Link*	Stainless Steel
21	Locating Pin	Stainless Steel
22	Orifice Button Arm*	Stainless Steel
30	Washer*	Stainless Steel
33	Clevis*	Stainless Steel
34	Lock Washer*	Stainless Steel

**\*RECOMMENDED REPAIR PART KIT**

TABLE 1. AIR RELEASE VALVE PARTS LIST

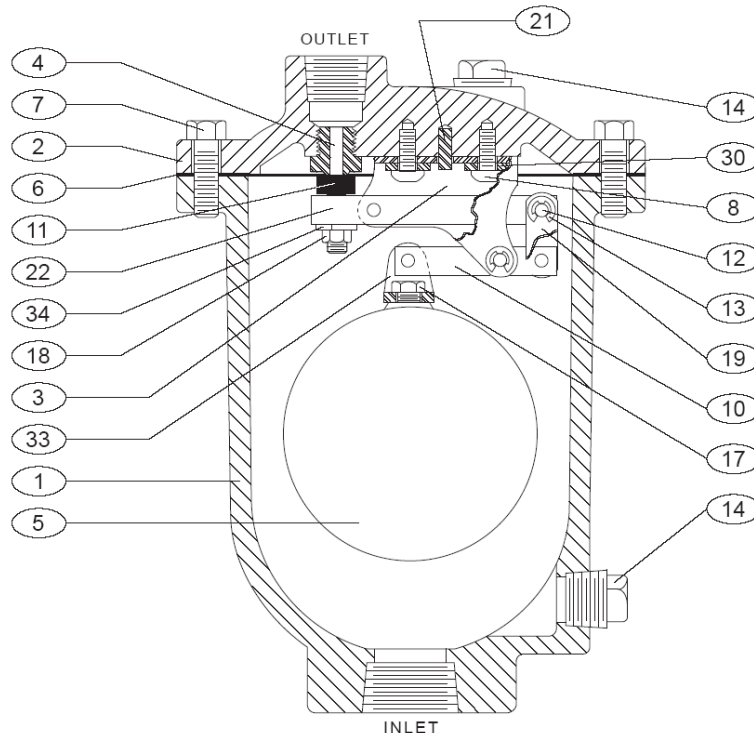
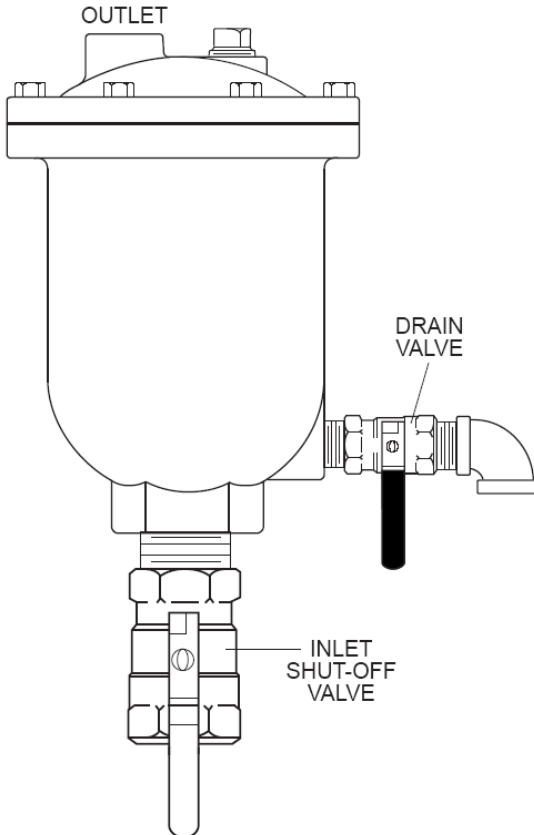

FIGURE 2. Compound Lever AIR RELEASE VALVE

## MAINTENANCE

The Air Release Valve requires no scheduled lubrication or maintenance.

**INSPECTION:** Periodic inspection to verify operation can be performed. A manual drain valve can be installed in the lower drain plug to perform this operation as shown in Figure 3.



**FIGURE 3. Inspection Piping**

1. With the inlet shutoff valve open, partially open the drain valve until flow can be heard. If the air valve is working properly, water should be exhausted from the drain valve. If air is exhausted, follow steps 2-6.
2. Close the inlet shutoff valve.
3. Slowly open the drain valve to allow the fluid in the valve to drain.
4. Close the drain valve.
5. Slowly open the inlet shutoff valve to fill the valve with water. Observe the seating action and verify that the valve closes without leakage.

6. If leakage occurs, the valve should be removed and inspected for wear or possible damage from foreign matter.

## TROUBLESHOOTING

Several problems and solutions are presented below to assist you in troubleshooting the valve assembly in an efficient manner.

- **Leakage at Bottom Connection:** Tighten valve threaded connection. If leak persists, remove valve and seal threads with thread sealant.
- **Leakage at Cover:** Tighten bolts per Table 2, replace gasket.
- **Valve Leaks when Closed:** Flush valve to remove debris. Disassemble and inspect seat, orifice button, and float. NOTE: Many floats contain sand for weight but if water is detected, replace float.
- **Valve not Venting Air:** Check that operating pressure does not exceed Working Pressure on nameplate. Perform inspection steps 2-6 and disassemble valve if problem persists.

## DISASSEMBLY

The valve can be disassembled without removing it from the pipeline. Or for convenience, the valve can be removed from the line. All work on the valve should be performed by a skilled mechanic with proper tools. No special tools are required.

### **WARNING**

**The valve must be drained before removing the cover or pressure may be released causing injury.**

1. Close inlet shut-off valve. Open drain valve or remove drain plug. Remove the cover bolts (7) on the top cover.
2. Pry cover (2) loose and lift off valve body.
3. Remove the 2 retainer rings (13) and pivot pins (12) that pass through the lever frame (3). The float (5) and linkage will be free from the cover. Disconnect float from lever (10).

### DISASSEMBLY (Cont'd)

- To remove lever frame (3), remove two round-head fasteners (8). Rotate seat (4) counter-clockwise to remove.
- Remove locknut (18) and orifice button (11) from orifice button arm (22).
- Clean and inspect parts. Note: some floats contain sand for extra weight; if water is detected, replace float. Replace worn parts as necessary.

### REASSEMBLY

All parts must be cleaned and gasket surfaces should be cleaned with a stiff wire brush in the direction of the serrations or machine marks. Worn parts, gaskets and seals should be replaced during reassembly. Refer to Figure 2 on page 2.

- Apply Loctite PST No. 565 thread sealant to seat (4) and assemble to cover with maximum torque of 20 ft-lbs; DO NOT OVER-TORQUE.
- Assemble lever frame (3) to cover over locating pin (21) in cover. Secure with screws (8) and washers (30).
- Install new orifice button (11) flush to arm (22). Assemble lockwasher (34) and locknut (18) over orifice button but do not tighten.
- Connect arms (10 & 22) and assemble to lever frame (3) with four pivot pins (12) and retaining rings (13); rings should snap over pins.
- Adjust orifice button (11) so that orifice button arm (22) slopes up about 1/16" when resting gently against seat (4) as shown in Figure 4. Secure button by tightening lockwasher (34) and nut (18).
- Attach float (5) by installing last pivot pin (12) into lever frame (3). Float should move freely pressing the orifice button (11) against the seat (4) when pushed upward. Verify that all retainer rings (13) are properly secured.
- Assemble gasket (6) and cover (2) over bolt holes in body (1).

- Insert lubricated bolts (7) and tighten to the torques listed in Table 2.
- Place valve back in service. Refer to the Installation instructions on page 2. Slowly open inlet isolation valve.

<u>SIZE</u>	<u>TORQUE (FT-LBS)</u>
7/16"	30
1/2"	45
7/8"	202

TABLE 2. VALVE COVER BOLT TORQUES

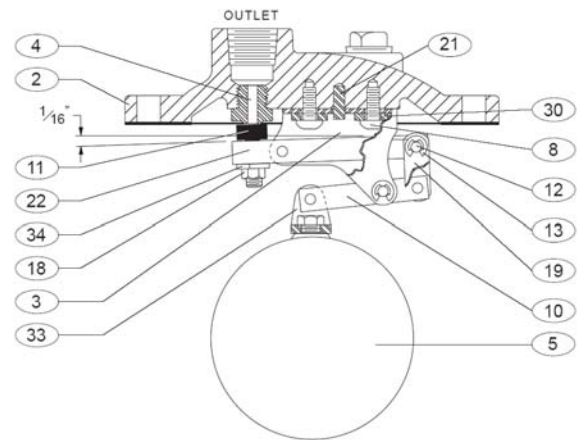

FIGURE 4. ORIFICE BUTTON ADJUSTMENT  
(See REASSEMBLY, Step 5)

### PARTS AND SERVICE

Parts and service are available from your local representative or the factory. Make note of the valve Model No and Working Pressure located on the valve nameplate and contact:

Val-Matic Valve and Mfg. Corp.  
905 Riverside Drive  
Elmhurst, IL 60126  
Phone: (630) 941-7600  
Fax: (630) 941-8042  
[www.valmatic.com](http://www.valmatic.com)

A sales representative will quote prices for parts or arrange for service as needed.

## LIMITED WARRANTY

All products are warranted to be free of defects in material and workmanship for a period of one year from the date of shipment, subject to the limitations below.

If the purchaser believes a product is defective, the purchaser shall: (a) Notify the manufacturer, state the alleged defect and request permission to return the product; (b) if permission is given, return the product with transportation prepaid. If the product is accepted for return and found to be defective, the manufacturer will, at his discretion, either repair or replace the product, f.o.b. factory, within 60 days of receipt, or refund the purchase price. Other than to repair, replace or refund as described above, purchaser agrees that manufacturer shall not be liable for any loss, costs, expenses or damages of any kind arising out of the product, its use, installation or replacement, labeling, instructions, information or technical data of any kind, description of product use, sample or model, warnings or lack of any of the foregoing. NO OTHER WARRANTIES, WRITTEN OR ORAL, EXPRESS OR IMPLIED, INCLUDING THE WARRANTIES OF FITNESS FOR A PARTICULAR PURPOSE AND MERCHANTABILITY, ARE MADE OR AUTHORIZED. NO AFFIRMATION OF FACT, PROMISE, DESCRIPTION OF PRODUCT OF USE OR SAMPLE OR MODEL SHALL CREATE ANY WARRANTY FROM MANUFACTURER, UNLESS SIGNED BY THE PRESIDENT OF THE MANUFACTURER. These products are not manufactured, sold or intended for personal, family or household purposes.



**VAL-MATIC® VALVE AND MANUFACTURING CORP.**

905 Riverside Dr. • Elmhurst, IL 60126  
Phone (630) 941-7600 • Fax (630) 941-8042  
[www.valmatic.com](http://www.valmatic.com)