

# Val-Matic® Air / Oil Hydraulic Panel Pump Control System

## Operation, Maintenance and Installation Manual

INTRODUCTION.....	1
RECEIVING AND STORAGE .....	1
DESCRIPTION OF OPERATION.....	1
INSTALLATION.....	2
START UP AND TEST .....	2
MAINTENANCE .....	5
TROUBLESHOOTING .....	5
DISASSEMBLY .....	5
REASSEMBLY .....	5
PARTS AND SERVICE .....	7
WARRANTY .....	8



VALVE AND MANUFACTURING CORP.

---

905 Riverside Dr. • Elmhurst, IL 60126  
Phone (630) 941-7600 • Fax (630) 941-8042  
[www.valmatic.com](http://www.valmatic.com)

# AIR / OIL HYDRAULIC PANEL OPERATION, MAINTENANCE AND INSTALLATION

## INTRODUCTION

This manual will provide you with the information to properly install and maintain the hydraulic panel to ensure a long service life. The panel is ruggedly constructed with rigid copper piping to give years of trouble free operation with clean air and oil service. The panel is installed near the ball, butterfly, or plug valve and piped to the valve cylinder and an 80-125 psig air supply pressure source.

For proper operation of the pump control valve, the panel must be wired to the pump control panel. The panel model number, voltage, and maximum supply pressure are stamped on the nameplate for reference.

## RECEIVING AND STORAGE

Inspect the panel upon receipt for damage in shipment. Unload the panel carefully to the ground without dropping. When lifting, the panel should be lifted with the door secured.

The panels should remain crated, clean and dry until installed to prevent weather related damage. For long-term storage greater than six months, the panels should be stored indoors or the ends of the pipes sealed to prevent weather related damage.

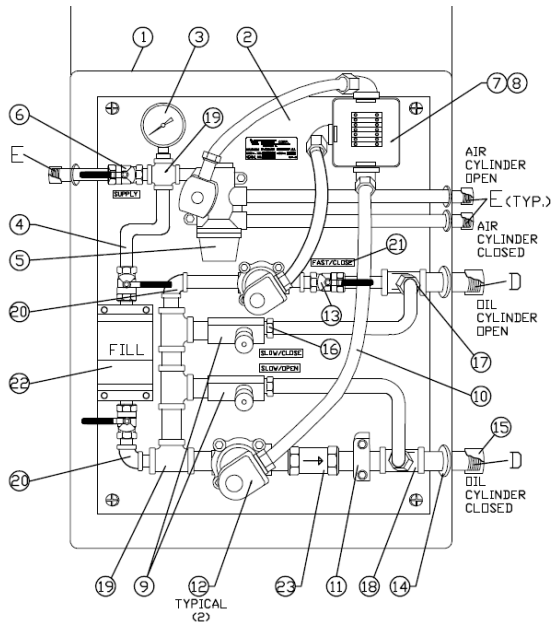
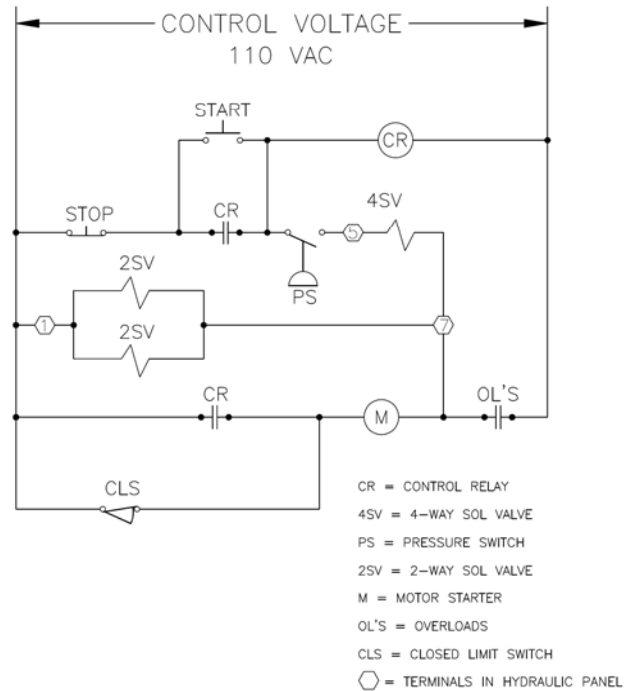

**FIGURE 1. Air/Oil Hydraulic Panel**

## DESCRIPTION OF OPERATION

### GENERAL:

The air/oil panel Supply (E) is connected to a source of pressurized air (typically 80-100 psig). The panel is connected to an air cylinder and an oil slave cylinder on the opposite side of the actuator. The opening and closing of the pump control valve is controlled by the air/oil hydraulic panel which is wired to the pump controls. A typical wiring method is shown in Figure 2.



**Figure 2. Typical Wiring Diagram**

### PUMP START SEQUENCE:

When the "Start" button is pressed, a control relay (CR) in the main pump panel is energized and its contact energizes the pump motor starter (M). The pump builds pressure against the closed pump control valve. When the pressure switch (PS) mounted on the pipeline trips, the 4-Way solenoid valve (5) in the hydraulic panel is energized. The air supply media is then directed to open the pump control valve slowly (i.e. 1-5 minutes) as controlled by the oil circuit and "Slow Open" flow control valve (9).

### PUMP STOP SEQUENCE:

When the "Stop" button is pressed, the control relay (CR) is de-energized and its contact de-energizes the 4-Way solenoid valve (5) in the hydraulic panel. The pump motor (M) continues to run. The supply media is then directed to close the pump control valve slowly (i.e. 1-5 minutes) as controlled by the "Slow Close" flow control valve (9). When the valve reaches the closed position, the closed limit switch (CLS) on the valve opens and de-energizes the pump.

### EMERGENCY STOP SEQUENCE:

Upon loss of electrical power or pump overload trip (OL's), the solenoid valves are de-energized and the supply media is directed through the 4-Way (5) and the two 2-Way (12) solenoid valves, which closes the pump control valve rapidly (i.e. 10-30 seconds) as controlled by the ball valve (13).

## INSTALLATION

These instructions are provided to aid in the installation of this equipment. Val-Matic Valve cannot be responsible for improper installation.

### **WARNING**

To reduce the risk of electric shock, serious injury or death when installing this equipment, follow these basic precautions:

1. Read all instructions before powering the panel.
2. Observe all local codes and ordinances.
3. Be sure to follow grounding instructions.
4. Use a qualified electrician for making wiring connections.

### SELECTING THE LOCATION

The panel can be floor or wall mounted within 10 feet of the control valve. If the panel is further away, the operation of the control valve may be slower. The panel can be mounted above or below the valve cylinder but should be at a convenient elevation for easy access. Allow sufficient space for the door to swing fully open and allow space to make the four pipe connections on the side of the panel.

### SUPPLY AND DRAIN CONNECTIONS

The supply connection is located on the left side of the panel and is made to a clean pressure connection of air. The supply media must be clean; 10 micron filtration is recommended. A pressure regulator set at 80 psig is needed when the supply

pressure exceeds the pressure rating of the panel and can be helpful in providing consistent valve operation. The supply line should be of a size equal or greater than the Supply connection on the panel.

### CYLINDER CONNECTIONS

The pipes extending out the right side of the panel are connected to the air and oil ports on the valve actuator with twin cylinders. The air cylinder is the power cylinder. The oil cylinder controls the speed of operation. The pipes can be any material suitable for the supply pressure and media but should be at least equal in diameter to that of the connections on the panel. It is important to connect the "OPEN" pipe to the cylinder port that drives the valve open. If the oil cylinder is above the panel, it will be important to install tees and bleed valves in the pipes adjacent to the cylinder. If the panel is above the oil cylinder, it will be important to install tees and bleed valves in the pipes adjacent to the control panel. Close the ball valve in the panel at the supply connection.

### WIRING CONNECTIONS TO PANEL

There are four terminal connections in the internal cabinet junction box. Connect the ground terminal to a suitable ground wire per local codes. Connect terminal (5) to the 110V "Open" control signal from the pump motor control station. There are many different configurations possible, but a common one is shown in Figure 2. Connect Terminal (1) to the high side of the control voltage. Connect (7) to the low side of the control voltage or to the motor overload circuit as shown in Figure 2. Replace the cover on the terminal junction box.

### WIRING TO PUMP CONTROL VALVE

As shown in Figure 2, a closed limit switch (CLS) located on the pump control valve is needed to signal the pump circuit that the valve is closed and it is safe to shut down the pump. The wiring from the valve limit switch assembly is connected directly to the pump control panel and not the hydraulic panel.

## START UP AND TEST

Before the pump is put in operation, the pump control valve and hydraulic panel should be tested independently. Lock out the pump start sequence and isolate the pump control valve.

### OIL FILL

1. Fill the oil cylinder and oil lines with hydraulic oil. Connect the lines to the control panel. Use the bleed ports that were added in the lines either by the panel or the oil cylinder to remove air and fill the oil system with oil.
2. Add oil to the air-oil tank (22) until lines are full of oil. Fill to Full line on tank. When the cylinder

travels back and forth the oil level rises and falls because the oil cylinder rod volume.

3. Add pressure to top of tank using the ball valve on top of tank as needed.

#### PRESSURE TEST (Refer to Figure 3)

1. Find the manual override lever on the 4-Way solenoid valve under the valve and turn it counter clockwise (CCW) to disengage it.
2. Close the shut off valve in the panel on the "Supply" connection.
3. Close the flow control valves (9) and then open them about 2 turns.
4. Slowly apply pressure to the panel by partially opening the shut off valve. Air supply pressure should flow into the panel and register on the supply gauge.
5. Verify that the supply pressure does not exceed the pressure rating shown on the panel nameplate (typically 150 psi max.)
6. Continue to let the supply media flow through the panel and towards the closed port of the valve cylinder. There will be trapped air in the oil line to the valve, so crack open a bleed valve near the cylinder to vent the air. It may take a few minutes to fill the lines and cylinder with media. The "Slow Close" flow control valve can be opened up a few more turns to speed up the process if desired.
7. Provide electrical power to the panel (Terminal 1) but do not provide the open signal to terminal (5). The flow through the panel should not change and the pump control valve should still be closed. Adding power energizes the 2-Way solenoid valves and blocks flow through them thereby allowing the 4-way valve to fully control the pump control valve.
8. Flip the manual override lever on the 4-Way clockwise (CW) and the flow should be directed to the open piping. The "Slow Open" flow control valve can be opened up a few more turns to speed up the process if desired. The final open and close setting is typically 60-300 seconds.
9. Using the lever on the 4-Way, send the pump control valve open and closed 3 times to remove the air in the oil lines. Bleed as necessary. Refill the oil tank if the level drops.
- 10 With the valve in the open position, remove the electrical power. The pump control valve should

rapidly close (10-30 sec) as controlled by the "Fast Close" ball valve located in the lower line of the panel.

#### VALVE TEST

1. Provide electrical power to the panel (Terminal 1) but do not provide the open signal to terminal (5). The 4-way valve should control the pump control valve.
2. Flip the manual override lever on the 4-Way CW and the flow should be directed to the open piping.
3. Check the open limit switch setting on the pump control valve. The limit switch should trip a few degrees from full open. It can be adjusted by removing the cover and temporarily disengaging the opening cam and turning it until the switch trips and then reengaging it.
4. Flip the lever on the 4-way CCW and send the pump control valve closed. Verify that the closed limit switch tripped. If it did not trip, adjust the cam or for more precise adjustment, the coupling under the switch housing can be loosened and retightened.

#### PUMP START

The pump control valve can now be operated by the main pump control panel by providing an open signal to terminal 5. The open signal can be 1) immediate when the pump is started, 2) delayed by a pressure switch to allow the pump to build pressure, or 3) delayed by a timer to allow time for air to be vented.

1. For a safe start up, it is recommended that the first automatic pump start be conducted with the pump control isolation valve closed.
2. Start the pump and verify that pressure builds and an open signal is provided to terminal (5). The pump control valve should open slowly (60-300 seconds).
3. Initiate the Pump Stop sequence. The Stop Sequence should de-energize terminal (5) and the pump should continue to run.
4. De-energizing terminal (5) sends the pump control valve closed at the slow rate (60-300 seconds).
5. When the valve is nearly closed, the closed limit switch should be wired to trip the pump circuit.

6. Allow the pump water level to stabilize and start the pump and valve again, steps 1 and 2 above.
7. Simulate a power failure by removing power from the pump and valve. The valve should close rapidly in 10-30 seconds.

NOTE: The valve travel times are field adjustable to prevent water hammer in the distribution system as directed by the pipeline designer.

8. Provide power to the panel again, open the pipeline isolation valve, and the pump control valve is ready for normal operation.

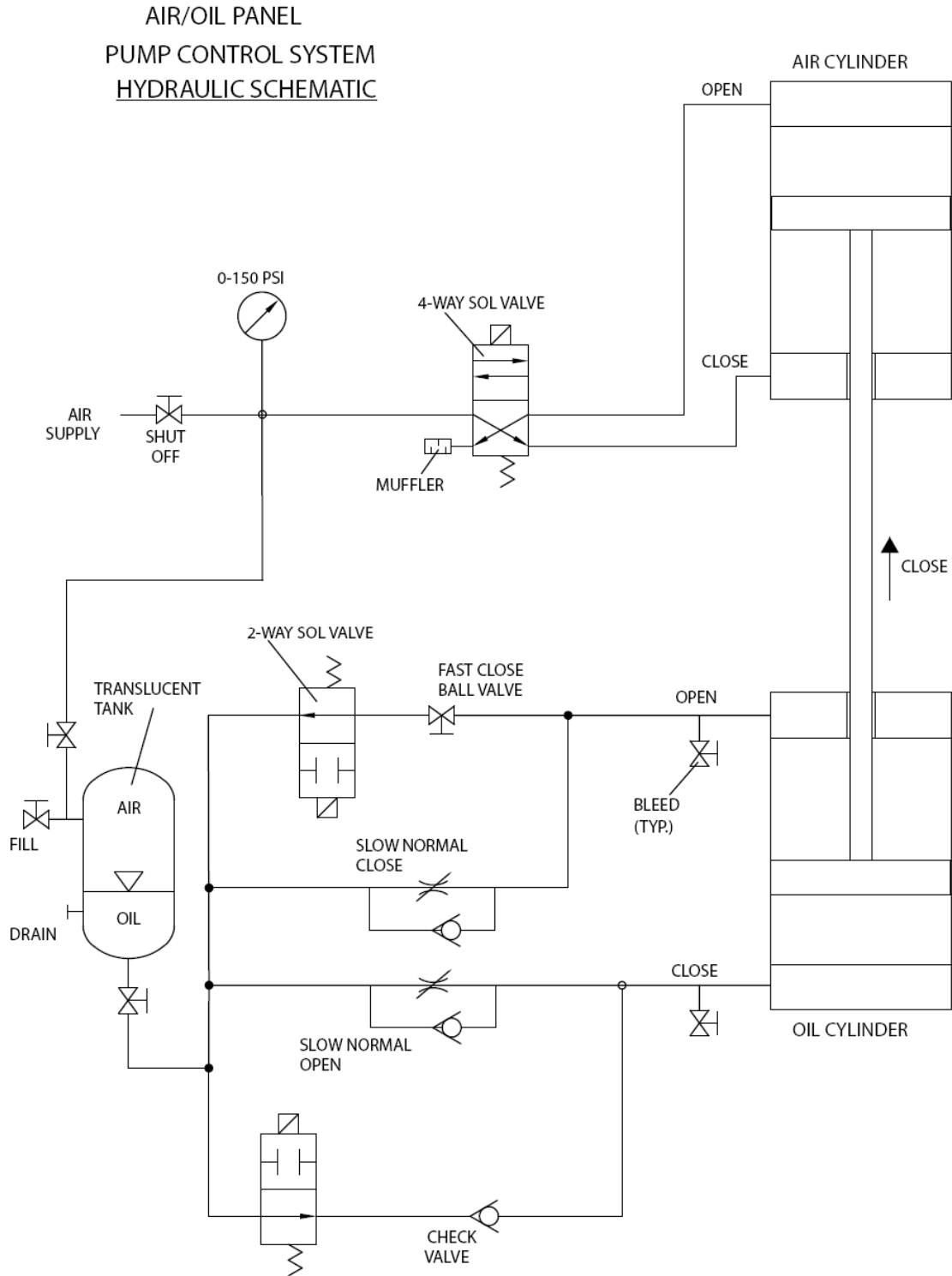

**Figure 3. Typical Hydraulic Schematic**

## MAINTENANCE

The air/oil hydraulic panel should provide smooth operation of the pump control valve. The valve operation should be monitored regularly (i.e monthly) to look for erratic valve travel or unusually slow operation (greater than the normally set times).

**LUBRICATION:** The panel requires no lubrication or fluids for proper operation.

**INSPECTION:** Cleanliness of the supply media is important. Periodic inspection of the supply media filters and supply pressure are necessary to assure proper operation. Replace filters regularly depending on frequency of operation. Check the piping and fittings for leaks. If leakage is observed, tighten the appropriate fitting or replace the leaky fitting. Check the oil level in the tank regularly.

## TROUBLESHOOTING

Several problems and solutions are presented below to assist you in trouble shooting the hydraulic panel in an efficient manner. The pipeline isolation valve should be closed during troubleshooting, to prevent reverse flow through the pump.

1. Leakage at fittings. Re-tighten or replace fittings.
2. Control Valve fails to open or close.
  - a) Flow control valves may be clogged. Close the pipeline isolation valve. Cycle the control valve back and forth with the lever on the 4-Way valve. Fully open the flow control valves and reset them while the valve is in motion.
  - b) Solenoid Valves may have failed. First, turn lever under 4-Way solenoid valve. If control valve operates, then check that the open signal is provided to terminal (5). Replace 4-Way solenoid.
  - c) Verify that supply pressure is sufficient to operate valve. Check pressure on gauge.
3. Control valve operates too quickly. Reset flow control valves.
4. Noisy Operation: Some flow noise is normal. Loud noise from the solenoid valves may indicate they require cleaning or service.

## DISASSEMBLY

Before working on the panel, the pump control valve should be isolated and the pump locked out.

## **WARNING**

**The panel may trap hydraulic pressure. Care must be taken to release pressure slowly or pressure may cause injury.**

Refer to Figure 4 for part identification.

1. Remove electrical power from the cabinet terminal box. Test terminals with multimeter to verify lack of power.
2. Isolate hydraulic power from the supply connection.
3. Shift the 4-Way with the manual override lever to relieve pressure in piping.
4. Remove piping connections from outside of cabinet.
5. Remove the 4 pipe nipples that extend through the cabinet walls.
6. Unbolt panel (2) from cabinet (1) and remove to provide better access to internal piping.
7. Remove 4 tubing runs (4) by loosening fitting nuts on each end.
8. Remove pipe clamps (11) to remove pipe runs from the panel.
9. Disassemble piping components as needed and repair/replace components.

The solenoid valve flexible conduit can remain connected to the terminal box if desired. To fully remove solenoid valves, the solenoid valve wires must be removed from the junction box.

## REASSEMBLY

All parts must be clean and threaded surfaces should be cleaned with a stiff wire brush to remove old pipe dope or thread tape. Worn parts, gaskets, and seals should be replaced during reassembly.

1. Repipe the two large pipe lower runs as shown in figure 4 using teflon paste sealant.
2. Attach to the panel (2) with the pipe clamps (11).
3. Connect the gauge (3) and flow control valves (9) to the 4-Way Solenoid Valve as shown.

4. Rewire the solenoid valves to the junction box if needed
5. Insert the cabinet seals (14) into the side walls of the cabinet.
6. Insert the 4 pipe nipples through the seals (14) and tighten into the cabinet.
7. Make the connections to the valve cylinder.

8. Make the connections to supply and drain.
9. Apply pressure and check for leaks.
10. Reconnect wires.

Repeat "Start-Up and Test" as given on page 2 of this manual.

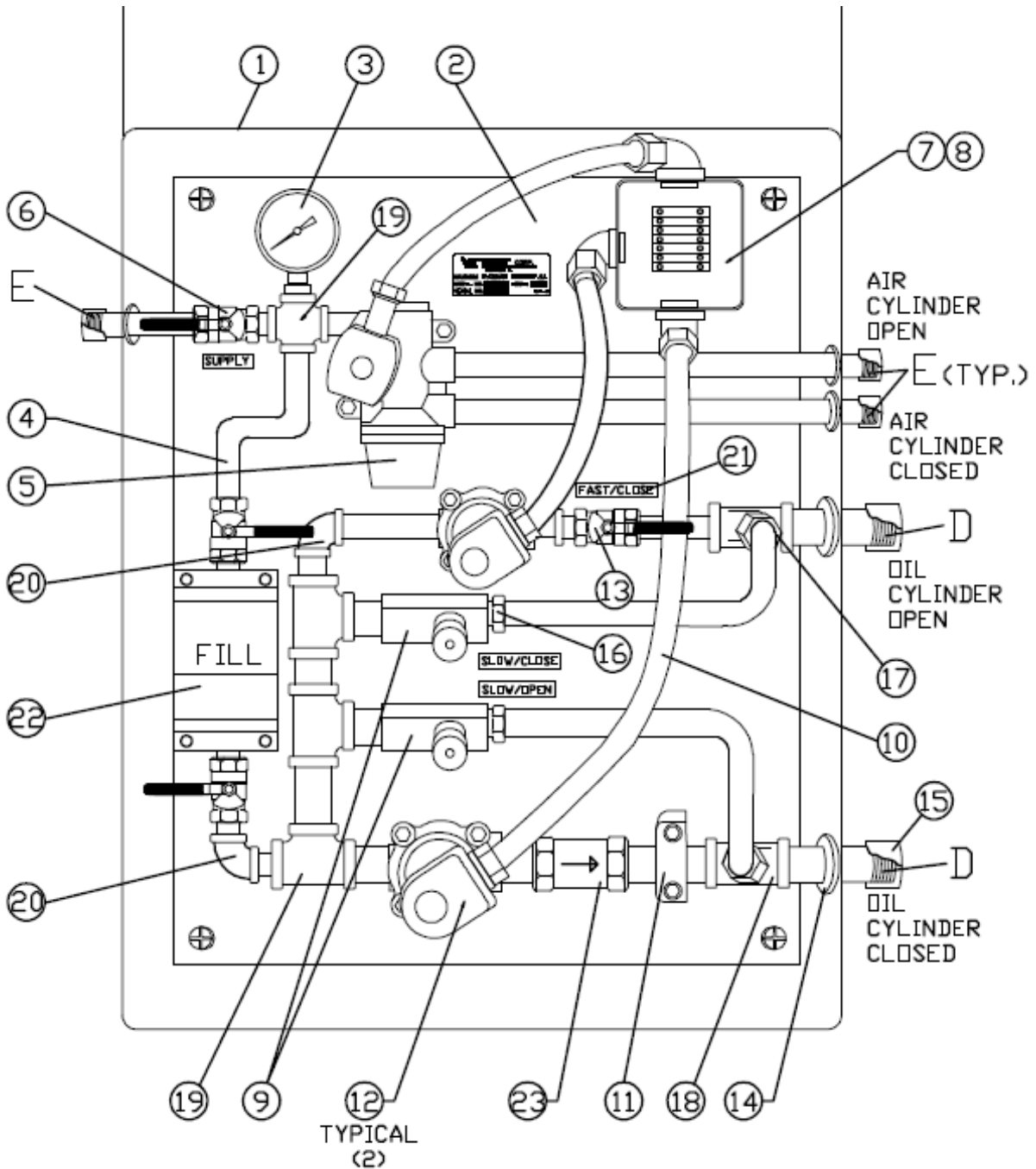

**Figure 4. Air-Oil Hydraulic Panel Construction**

NO.	PART NAME	MATERIAL	NO.	PART NAME	MATERIAL
1	Enclosure	Fiberglass, NEMA 4X	13	Ball Valve	Brass, 600 psi
2	Panel	Fiberglass	14	Bulkhead Seal	Resilient
3*	Pressure Gauge	Stainless Steel, 0-160 psig.	15	Protective Cap	Polyethylene
4	Tubing / Pipe	Copper	16	Tubing Adapter	Brass
5*	4-Way Sol. Valve	ASCO 8344	17	90 Elbow	Brass
6	Ball Valve	Brass, 600 psi	18	Reducing Tee	Red Brass
7	Junction Box	Fiberglass, NEMA 4X	19	Pipe Tee	Red Brass
8	Terminal Strip	SQ-D 9080-GA6	20	90 Elbow	Red Brass
9	Flow Control Valve	Parker F Series	21	Labels	Plastic
10	Conduit	Liquid-Tite	22	Air/Oil Tank	Steel
11	Clamp Set	Non-Metallic	23	Check Valve	Parker C
12*	2-Way Sol. Valve	(2) ASCO 8210			

\* Recommended Spare Part

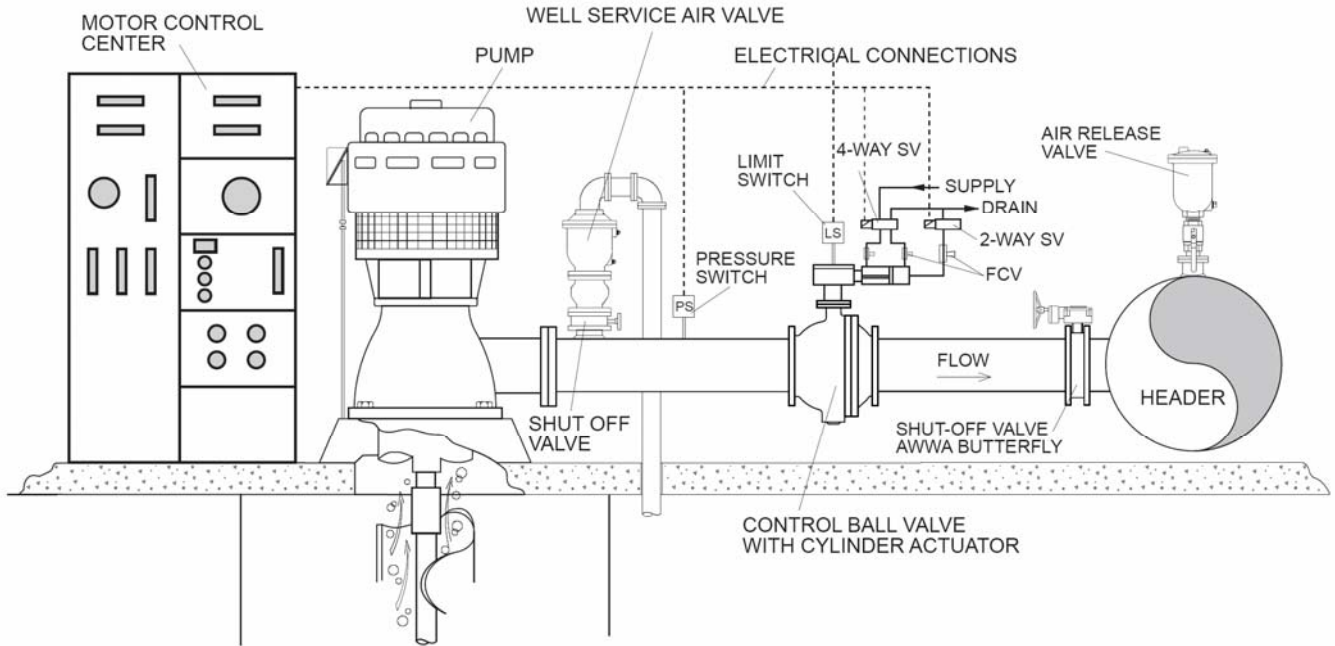

**Figure 5. Typical Pump Control Valve Installation**

**PARTS AND SERVICE**

Parts and service are available from your local representative or the factory. Make note of the Valve Size and Model Number located on the valve nameplate and contact:

Val-Matic Valve and Manufacturing Corp.  
 905 Riverside Drive  
 Elmhurst, IL 60126  
 Phone: (630) 941-7600  
 Fax: (630) 941-8042  
[www.valmatic.com](http://www.valmatic.com)

A sales representative will quote prices for parts or arrange for service as needed.

#### LIMITED WARRANTY

All products are warranted to be free of defects in material and workmanship for a period of one year from the date of shipment, subject to the limitations below.

If the purchaser believes a product is defective, the purchaser shall: (a) Notify the manufacturer, state the alleged defect and request permission to return the product; (b) if permission is given, return the product with transportation prepaid. If the product is accepted for return and found to be defective, the manufacturer will, at his discretion, either repair or replace the product, f.o.b. factory, within 60 days of receipt, or refund the purchase price. Other than to repair, replace or refund as described above, purchaser agrees that manufacturer shall not be liable for any loss, costs, expenses or damages of any kind arising out of the product, its use, installation or replacement, labeling, instructions, information or technical data of any kind, description of product use, sample or model, warnings or lack of any of the foregoing. NO OTHER WARRANTIES, WRITTEN OR ORAL, EXPRESS OR IMPLIED, INCLUDING THE WARRANTIES OF FITNESS FOR A PARTICULAR PURPOSE AND MERCHANTABILITY, ARE MADE OR AUTHORIZED. NO AFFIRMATION OF FACT, PROMISE, DESCRIPTION OF PRODUCT OF USE OR SAMPLE OR MODEL SHALL CREATE ANY WARRANTY FROM MANUFACTURER, UNLESS SIGNED BY THE PRESIDENT OF THE MANUFACTURER. These products are not manufactured, sold or intended for personal, family or household purposes.



**VALVE AND MANUFACTURING CORP.**

---

905 Riverside Dr. • Elmhurst, IL 60126  
Phone (630) 941-7600 • Fax (630) 941-8042  
[www.valmatic.com](http://www.valmatic.com)