

PLUG STOP ADJUSTMENT SCREWS

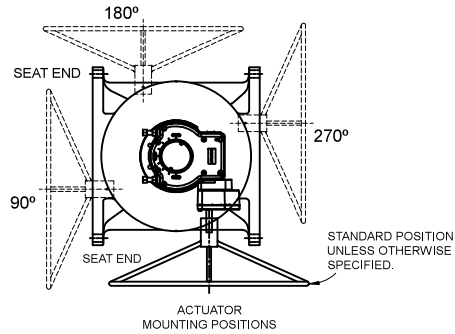

ACTUATOR MOUNTING POSITIONS

STANDARD POSITION UNLESS OTHERWISE SPECIFIED.

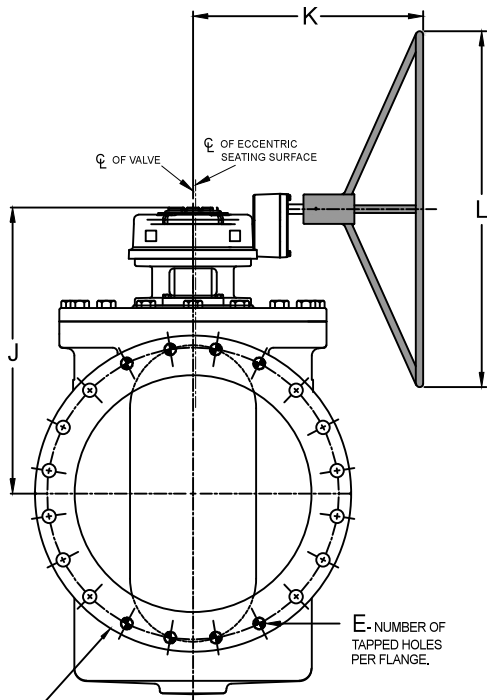

FLANGE DRILLING CONFORMS TO ANSI B16.1 CLASS 125

COLD WORKING PRESSURE 150 P.S.I.
HYDRO TEST PRESSURE 225 P.S.I.

E - NUMBER OF TAPPED HOLES PER FLANGE.

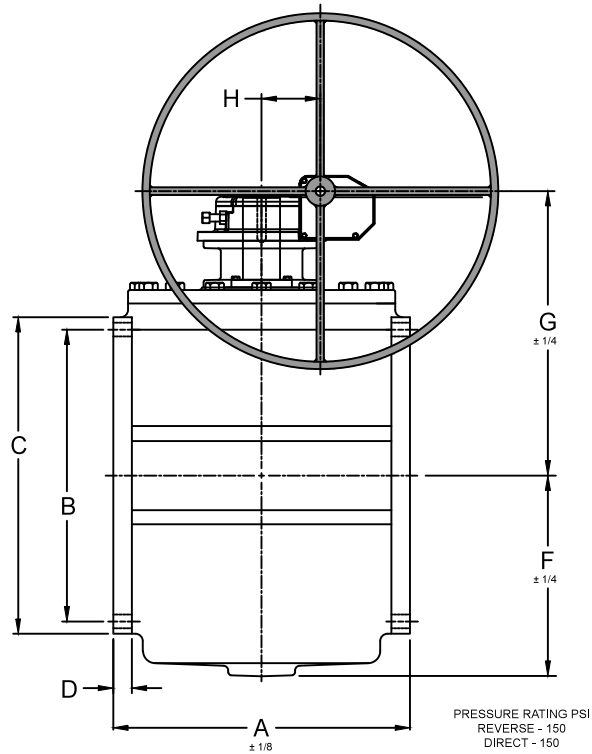

PRESSURE RATING PSI
REVERSE - 150
DIRECT - 150

SEE DRAWING NO. VM-5804RN-M FOR MATERIALS OF CONSTRUCTION.

END FLANGE DRILLING CONFORMS TO ANSI B16.1

DIMENSIONS, INCHES

VALVE SIZE	MODEL NUMBER	A	B	C	D	E QTY.	E TAP	E DEEP	F	G	H	J	K	L	BOLT SIZE	NO. OF BOLTS	NO. OF TURNS
24	5824R/7Q36	30.00	29.50	32.00	1.88	8	1 1/4-7	1.88	20.25	28.75	5.93	29.00	23.25	36.00	1 1/4	20	90

ANSI CLASS 125 FLANGED CAM-CENTRIC RECTANGULAR PLUG VALVE WITH WORM GEAR ACTUATOR

DATE 3-11-14



VALVE AND MANUFACTURING CORP.

DRWG. NO.

VMC-5824R/WGA