

INTEGRAL SOIL PIPE
ALIGNMENT/ MOTOR
ATTACHMENT
FLANGE

HANDWHEEL

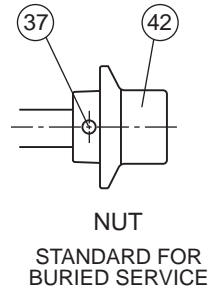
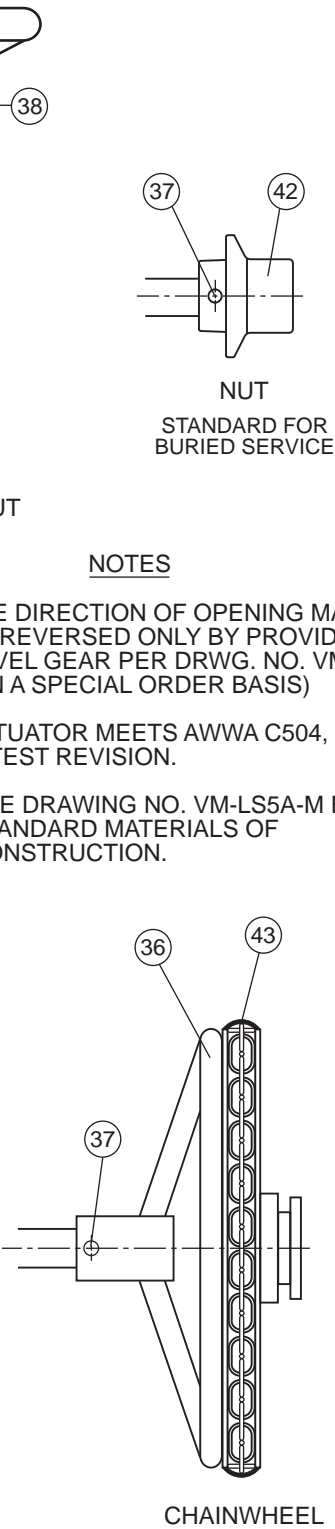

NUT
STANDARD FOR
BURIED SERVICE

NOTES

1. THE DIRECTION OF OPENING MAY BE REVERSED ONLY BY PROVIDING A BEVEL GEAR PER DRWG. NO. VM-1H24 (ON A SPECIAL ORDER BASIS)
2. ACTUATOR MEETS AWWA C504, LATEST REVISION.
3. SEE DRAWING NO. VM-LS5A-M FOR STANDARD MATERIALS OF CONSTRUCTION.

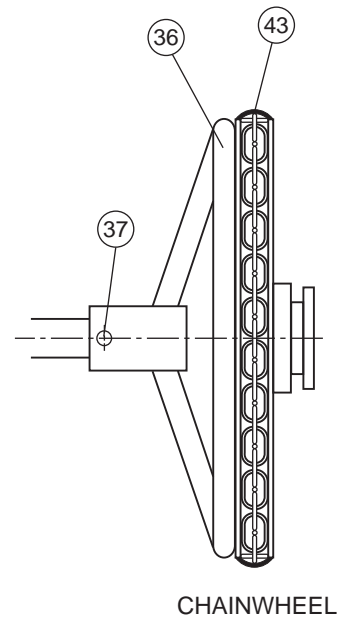

CHAINWHEEL

CLOSED POSITION

ABOVE GROUND SERVICE
INDICATOR SHOWN. BURIED SERVICE
NON-ROTATING COVER IS LARGER
IN DIAMETER AND BOLTED TO THE
HOUSING COVER INSTEAD OF
THE LEVER.

TRAVELING NUT ACTUATOR

DATE 8-22-08

VAL-MATIC[®] VALVE AND MANUFACTURING CORP.

DRWG. NO.

VM-LS5A