

SEE DRAWING NO. VM-9812-M FOR ANSI CLASS 125 MATERIALS OF CONSTRUCTION.

ANSI CLASS 125											
VALVE SIZE	MODEL NO.	A	B	C	D	E	F	G	H	BOLT SIZE	NO. OF BOLTS
12	9812	24	17	19	1 1/4	12	26	21	2 3/4	7/8	12
14	9814	30	18 3/4	21	1 3/8	14	29	25	4 1/8	1	12
16	9816	30	21 1/4	23 1/2	1 7/16	16	32	28	3/4	1	16
18	9818	33	22 3/4	25	1 9/16	18	36	30	2 1/2	1 1/8	16
20	9820	32	25	27 1/2	1 11/16	20	39	32	1/2	1 1/8	20
24	9824	38	29 1/2	32	1 7/8	24	46	37	1/2	1 1/4	20
30	9830	52	36	38 3/4	2 1/8	30	55	47	2 3/4	1 1/4	28
36	9836	59 1/2	42 3/4	46	2 3/8	36	65	51	2	1 1/2	32
42	9842	62 1/2	49 1/2	53	2 5/8	42	73	59	0	1 1/2	36
48	9848	65	56	59 1/2	2 3/4	48	82	69	-3/4	1 1/2	44
54	9854	78	62 3/4	66 1/4	3	54	90 7/8	75	1 3/8	1 3/4	44

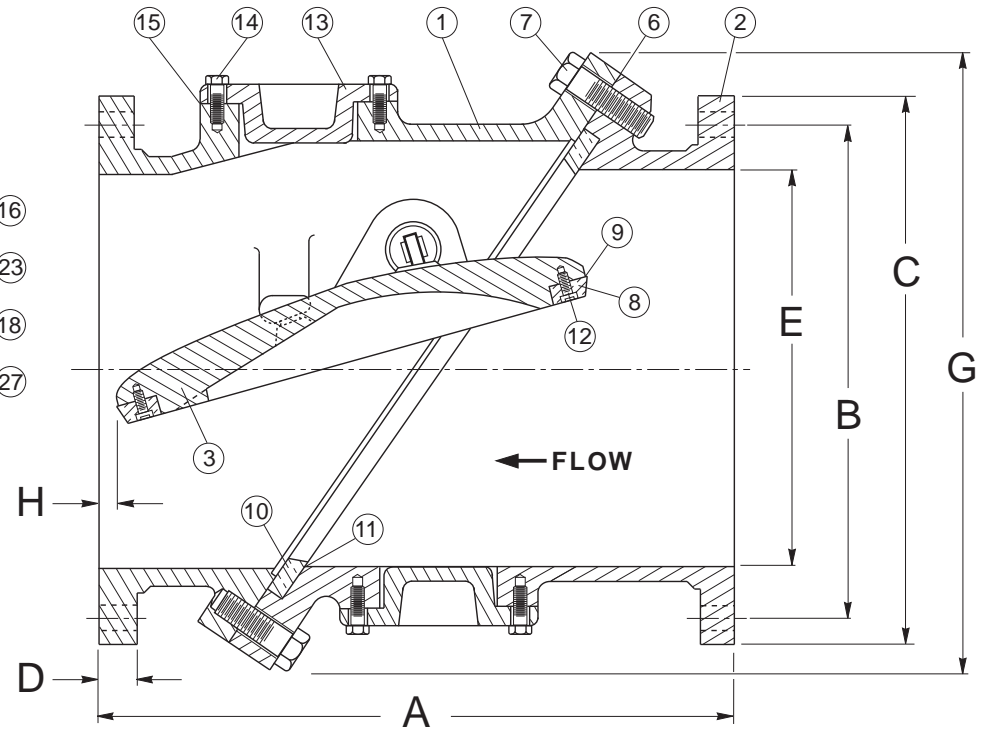

SEE DRAWING NO. VM-9712-M FOR ANSI CLASS 250 MATERIALS OF CONSTRUCTION.

ANSI CLASS 250											
VALVE SIZE	MODEL NO.	A	B	C	D	E	F	G	H	BOLT SIZE	NO. OF BOLTS
12	9712	24	17 3/4	20 1/2	2	12	26	21	2 3/4	1 1/8	16
14	9714	30	20 1/4	23	2 1/8	14	29	25	4 1/8	1 1/8	20
16	9716	30	22 1/2	25 1/2	2 1/4	16	32	28	3/4	1 1/4	20
18	9718	33	24 3/4	28	2 3/8	18	36	30	2 1/2	1 1/4	24
20	9720	32	27	30 1/2	2 1/2	20	39	32	1/2	1 1/4	24
24	9724	38	32	36	2 3/4	24	46	37	1/2	1 1/2	24
30	9730	52	39 1/4	43	3	30	55	47	2 3/4	1 3/4	28
36	9736	59 1/2	46	50	3 3/8	36	65	51	2	2	32
42	9742	62 1/2	52 3/4	57	3 11/16	42	73	59	0	2	36
48	9748	65	60 3/4	65	4	48	82	69	-3/4	2	40

Revised 3-19-10

ANSI CLASS 125 and 250 TILTED DISC® CHECK VALVE

DATE 5-19-80



VALVE AND MANUFACTURING CORP.

DRWG. NO.

VM-9812