

COLD WORKING PRESSURE
150 P.S.I.
HYDRO TEST PRESSURE
225 P.S.I.

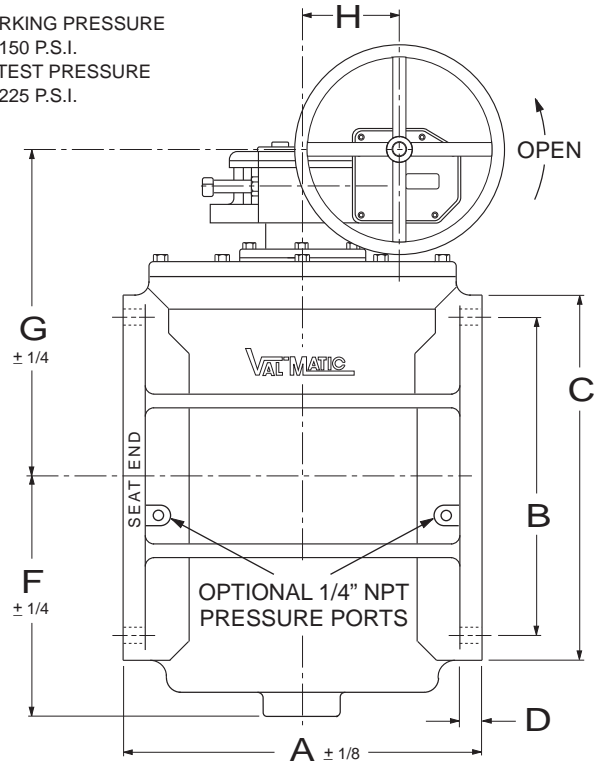

SEE DRAWING NO. VM-5804RN-M FOR STANDARD MATERIALS OF CONSTRUCTION.

* ASTERISK INDICATES VALVE MODEL NUMBERS W/O SPUR GEAR.

VALVE SIZE	MODEL NO.	PRESS. RATING P.S.I.		HD.WHEEL DIA.	A	B	C	D	E Qty	E Tap	E Deep	F	G	H	J	K	BOLT SIZE	NO. OF BOLTS	NO. OF TURNS			
		REVERSE	DIRECT																			
14	5814R/7E18*	50	100	18	17.00	18.75	21.00	1.38	4	1-8	1.56	13.00	19.31	5.62	22.00	15.25	1	12	20			
	5814R/7F24*	100	150	24									19.31	5.62	22.00	17.12						
	5814R/7G12	150	150	12									21.25	9.69	23.31	14.00						
16	5816R/7E24*	50	100	24	17.75	21.25	23.50	1.44	8	1-8	1.44	14.50	20.62	5.62	23.31	17.12	1	16	20			
	5816R/7F30*	100	150	30									20.62	5.62	23.31	18.62						
	5816R/7G14	150	150	14									22.56	9.69	24.62	14.62						
18	5818R/7J30*	50	100	30	21.50	22.75	25.00	1.56	8	1 1/8-7	1.87	16.25	22.25	5.62	24.94	18.62	1 1/8	16	60			
	5818R/7K18	100	150	18									22.25	5.62	24.94	18.62						
	5818R/7L24	150	150	24									25.12	7.38	25.25	19.25						
20	5820R/7M18	50	100	18	23.50	25.00	27.50	1.69	8	1 1/8-7	1.87	17.50	26.25	7.38	26.25	19.00	1 1/8	20	60			
	5820R/7N24	100	150	24												19.25				7.38	26.25	21.88
	5820R/7P30	150	150	30												21.88				7.38	26.25	21.88
24	5824R/7M24	50	100	24	30.00	29.50	32.00	1.88	8	1 1/4-7	1.87	20.25	29.00	7.38	29.00	19.25	1 1/4	20	60			
	5824R/7N30	100	150	30										19.25		7.38				29.00	21.88	
	5824R/7Q36	150	150	36										21.88		7.38				29.00	23.25	
30	5830R/7R24	50	100	24	37.50	36.00	38.75	2.12	8	1 1/4-7	2.12	24.00	31.00	4.06	35.12	16.12	1 1/4	28	85			
	5830R/7S30	100	150	30												16.12				4.06	35.12	16.12
	5830R/7T30	150	150	36												16.12				4.06	35.12	16.12
36	5836R/7S30	50	100	30	52.00	42.75	46.00	2.38	16	1 1/2-6	2.38	29.00	31.00	4.06	35.12	16.12	1 1/2	32	173			
	5836R/7V24	100	150	24									32.25			10.50				37.25	23.50	
	5836R/7W36	150	150	30									32.25			10.50				37.25	23.50	

ANSI CLASS 125 CAM-CENTRIC® FLANGED PLUG VALVE WITH WORM GEAR ACTUATOR

DATE Revised 9-14-10
10-19-95



VALVE AND MANUFACTURING CORP.

DRWG. NO.

VM-5814R/WGA