

COLD WORKING PRESSURE  
150 P.S.I.  
HYDRO TEST PRESSURE  
225 P.S.I.

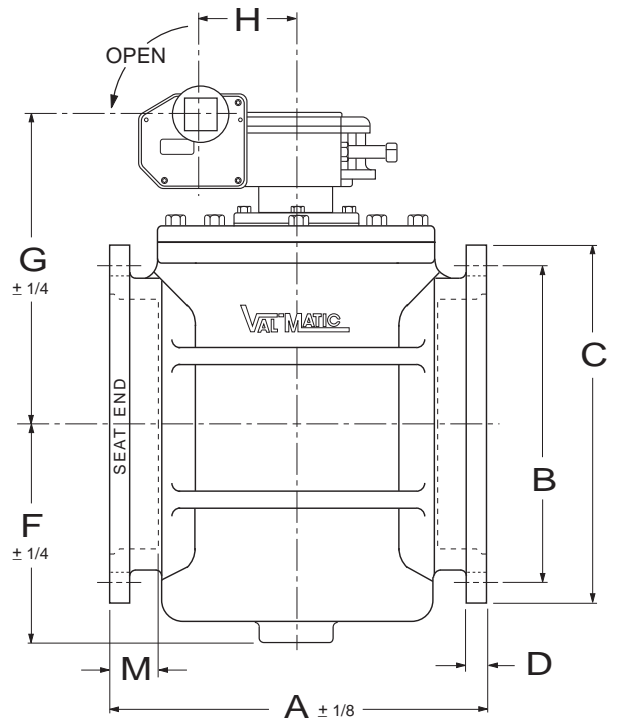

SEE DRAWING NO. VM-5842R-M FOR STANDARD MATERIALS OF CONSTRUCTION.

| VALVE<br>SIZE | MODEL<br>NO. | PRESS. RATING P.S.I. |        | A     | B     | C     | D    | F     | G     | H     | J     | K     | M     | BOLT<br>SIZE | NO. OF<br>BOLTS |
|---------------|--------------|----------------------|--------|-------|-------|-------|------|-------|-------|-------|-------|-------|-------|--------------|-----------------|
|               |              | REVERSE              | DIRECT |       |       |       |      |       |       |       |       |       |       |              |                 |
| 42            | 5742R/8Z02   | 150                  | 150    | 94.00 | 50.63 | 53.13 | 2.00 | 38.50 | 48.46 | 10.90 | 54.16 | 27.60 | 8.00  | 1 1/4        | 28              |
| 48            | 5748R/8Z02   | 150                  | 150    | 84.00 | 57.50 | 60.00 | 2.00 | 38.50 | 48.46 | 10.90 | 54.16 | 27.60 | 12.00 | 1 1/4        | 32              |

Revised 1-17-12

100% PORT CAM-CENTRIC® MECHANICAL JOINT PLUG VALVE WITH BURIED WORM GEAR ACTUATOR

DATE 1-10-12

**VAL-MATIC®**

VALVE AND MANUFACTURING CORP.

DRWG. NO.

VM-5742R/BWGA