

COLD WORKING PRESSURE
150 P.S.I.
HYDRO TEST PRESSURE
225 P.S.I.

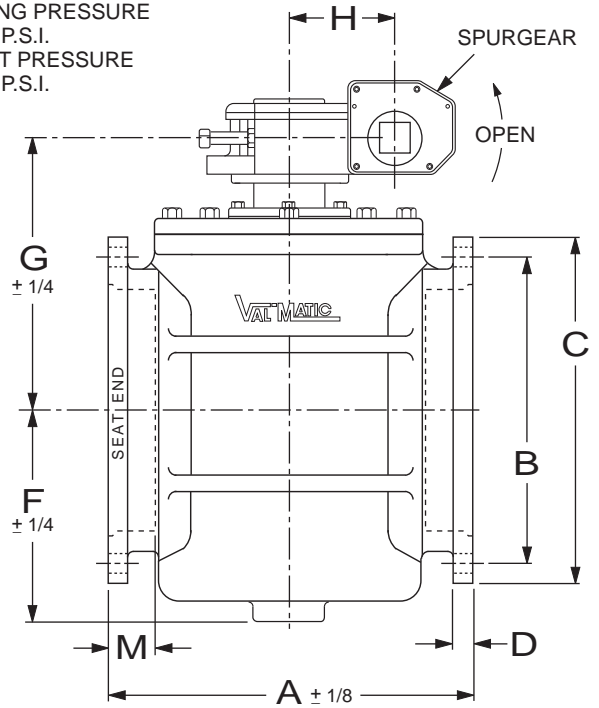

SEE DRAWING NO. VM-5804RN-M FOR STANDARD MATERIALS OF CONSTRUCTION. * ASTERISK INDICATES VALVE MODEL NUMBERS W/O SPUR GEAR.

| VALVE SIZE | MODEL NO. | PRESS. RATING P.S.I. | | A | B | C | D | F | G | H | J | K | M | BOLT SIZE | NO. OF BOLTS |
|------------|-------------|----------------------|--------|-------|-------|-------|------|-------|-------|-------|-------|-------|------|-----------|--------------|
| | | REVERSE | DIRECT | | | | | | | | | | | | |
| 12 | 5712R/8E02* | 100 | 150 | 27.25 | 16.25 | 17.69 | 1.25 | 13.00 | 19.31 | 5.63 | 22.00 | 13.00 | 3.50 | 3/4 | 8 |
| | 5712R/8F02* | 150 | 150 | | | | | | | | | | | | |
| 14 | 5714R/8E02* | 100 | 150 | 30.00 | 18.75 | 20.31 | 1.31 | 14.50 | 20.63 | 5.63 | 23.31 | 13.00 | 3.50 | 3/4 | 10 |
| | 5714R/8F02* | 150 | 150 | | | | | | | | | | | | |
| 16 | 5716R/8J02 | 100 | 150 | 28.50 | 21.00 | 22.56 | 1.38 | 16.25 | 25.25 | 7.38 | 26.25 | 12.63 | 3.50 | 3/4 | 12 |
| | 5716R/8K02 | 150 | 150 | | | | | | | | | | | | |
| 18 | 5718R/8J02 | 100 | 150 | 30.50 | 23.25 | 24.88 | 1.44 | 17.50 | 26.50 | 7.38 | 27.56 | 12.63 | 3.50 | 3/4 | 12 |
| | 5718R/8K02 | 150 | 150 | | | | | | | | | | | | |
| 20 | 5720R/8J02 | 100 | 150 | 49.00 | 25.50 | 27.13 | 1.50 | 20.25 | 29.25 | 9.69 | 30.25 | 12.63 | 3.50 | 3/4 | 14 |
| | 5720R/8K02 | 150 | 150 | | | | | | | | | | | | |
| 24 | 5724R/8R02 | 100 | 150 | 49.00 | 30.00 | 31.56 | 1.63 | 24.00 | 31.00 | 4.06 | 35.13 | 14.44 | 4.00 | 3/4 | 16 |
| | 5724R/8S02 | 150 | 150 | | | | | | | | | | | | |
| 30 | 5730R/8S02 | 50 | 100 | 60.00 | 36.88 | 39.13 | 1.81 | 29.00 | 31.00 | 4.06 | 35.13 | 14.44 | 4.00 | 1 | 20 |
| | 5730R/8T02 | 150 | 150 | | | | | | | | | | | | |
| 36 | 5736R/8X02 | 50 | 100 | 60.00 | 43.75 | 46.00 | 2.00 | 36.50 | 44.00 | 10.50 | 49.00 | 21.75 | 4.00 | 1 | 24 |
| | 5736R/8Z02 | 150 | 150 | | | | | | | | | | | | |

Revised 1-10-12

100% PORT CAM-CENTRIC® MECHANICAL JOINT PLUG VALVE WITH BURIED WORM GEAR ACTUATOR

DATE 10-22-99

VAL-MATIC®

VALVE AND MANUFACTURING CORP.

DRWG. NO.

VM-5712R/BWGA