

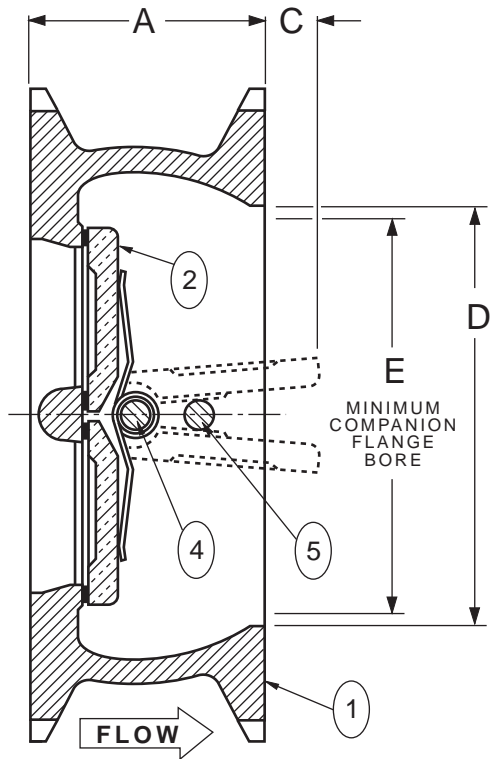

APPROVED  
SIZES 2 1/2" - 12"

LISTED

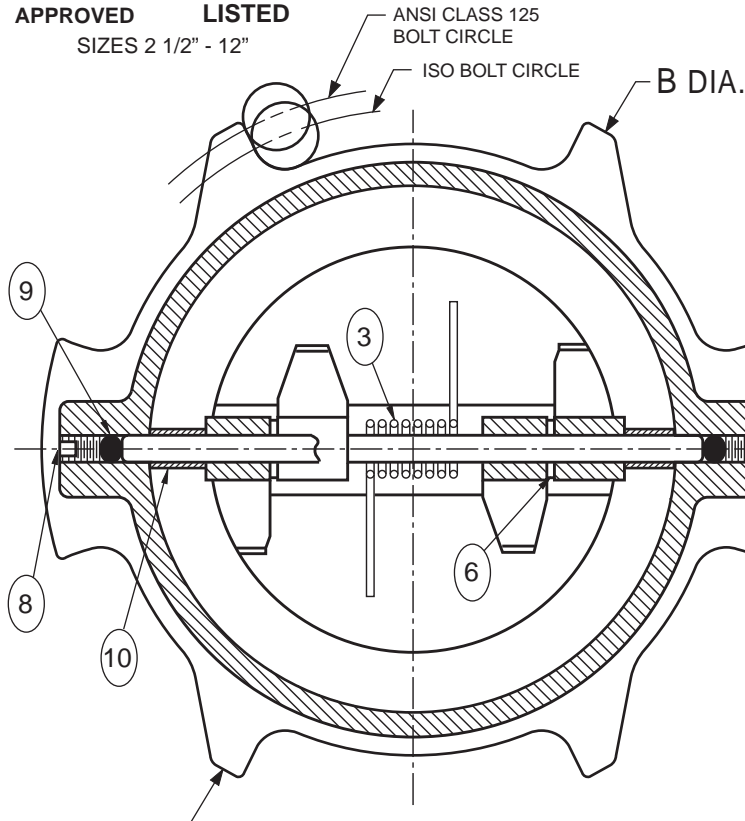

PART NO.	PART NAME
1	BODY
2	DISC
3	TORSION SPRING
4	DISC HINGE PIN
5	DISC STOP PIN

PART NO.	PART NAME
6	DISC THRUST BEARING
7	HINGE PIN RETAINER
8	STOP PIN RETAINER
9	STABILIZATION SPHERE
10	SPACER

ANSI CLASS 125 - ISO PN10/PN16						
VALVE SIZE	MODEL NO.	A	B	C	D	E
2	8802W	2.12	5.12	0.00	2.88	0.00
2 1/2	8825W	2.38	6.00	0.12	3.50	1.31
3	8803W	2.62	5.62	0.18	3.88	1.69
4	8804W	2.62	7.75	0.62	4.75	3.06
5	8805W	3.25	7.56	0.81	5.50	3.62
6	8806W	3.75	8.62	0.81	6.25	4.25
8	8808W	5.00	12.25	1.00	8.00	5.50
10	8810W	5.50	14.75	2.06	10.25	8.50
12	8812W	7.12	17.38	1.94	12.00	9.25

PRESSURE-TEMPERATURE RATING	
TEMP. °F.	MAXIMUM NON-SHOCK PRESSURE PSI
	DUCTILE IRON CONSTRUCTION
150°	250
200°	235
250°	220
HYDROSTATIC TEST PRESSURE	500

VAL-MATIC® DUAL DISC® CHECK VALVES CAN BE USED FOR HORIZONTAL FLOW OR VERTICAL FLOW-UP APPLICATIONS ONLY. CAUTION: FOR HORIZONTAL FLOW APPLICATIONS, VALVE MUST BE INSTALLED WITH THE DISC HINGE PIN IN THE VERTICAL POSITION. SEE DRAWING NO. VM-8802W-M FOR 2"-12" STANDARD MATERIAL OF CONSTRUCTION. FOR AIR SERVICE APPLICATIONS, SEE DRAWING NO. VM-8902W. SIZES 10 & 12 FURNISHED WITH LIFTING EYEBOLT.

Revision 9-25-06

WAFER STYLE DUAL DISC® CHECK VALVE

DATE 11-22-00



VALVE AND MANUFACTURING CORP.

DRWG. NO.

VM-8802W