

SEAT ADJUSTABLE FROM THIS SIDE.

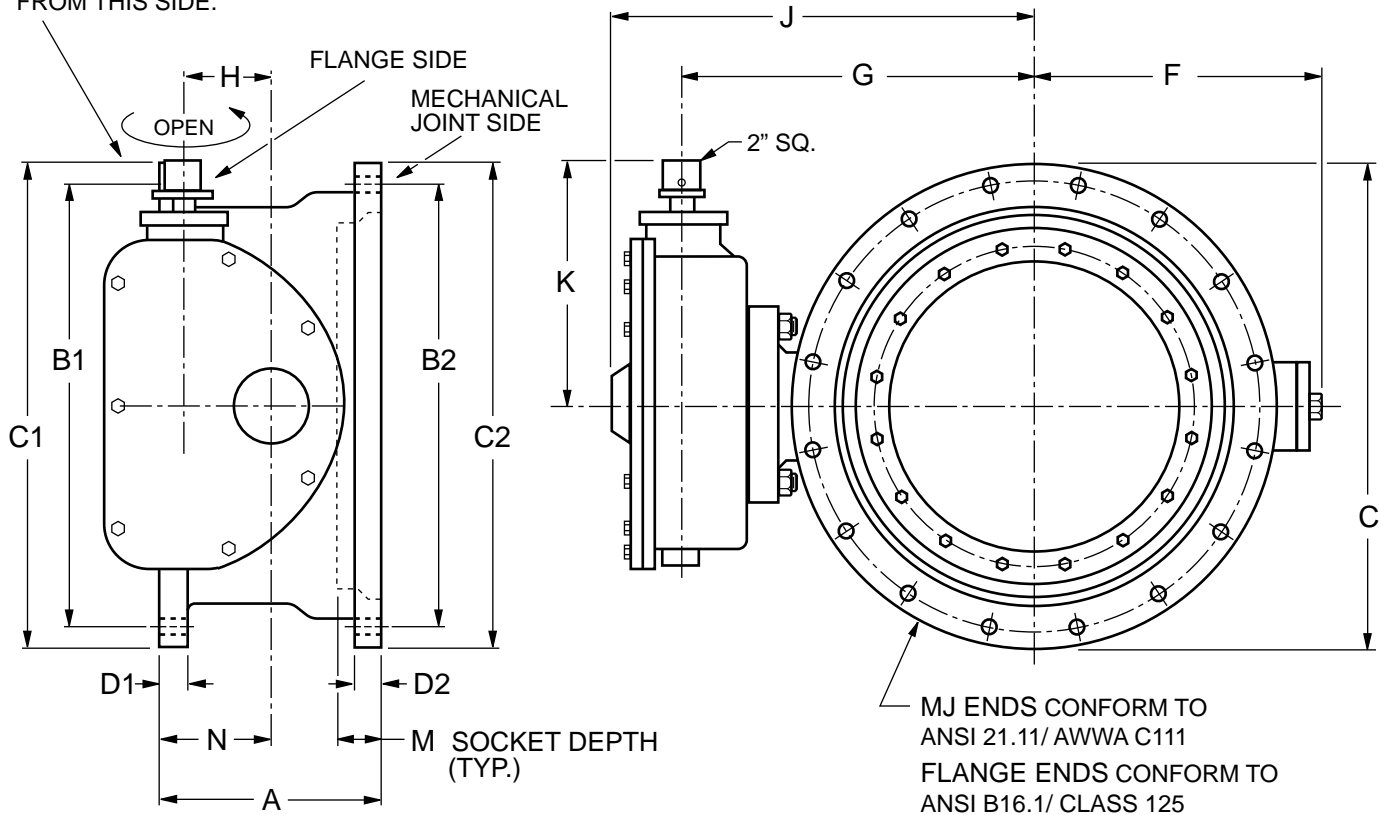

COLD WORKING PRESSURE 150 PSI (150B)

FLANGE X MECHANICAL JOINT DIMENSIONS, INCHES

VALVE SIZE	AWWA C504 CLASS	A	B1	B2	C1	C2	D1	D2	F	G	H	J	K	M	N	PD* Min.	TURNS TO OPEN	ACTUATOR SIZE	SHPG WT.
6	150B	6 3/4	9 1/2	9 1/2	11	11 1/8	1	1 1/16	7 1/32	8 1/4	1 1/2	10 1/4	7 5/8	2 1/2	2 1/2	4.63	15	LS-1	110
8	150B	7 1/2	11 3/4	11 3/4	13 1/2	13 3/8	1 1/8	1 1/8	8	9 3/16	1 1/2	11 1/4	7 5/8	2 1/2	3	6.59	15	LS-1	165
12	150B	8 5/8	17	16 1/4	19	17 15/16	1 1/4	1 1/4	11 1/16	12 3/4	2	15 1/4	8 5/8	2 1/2	4	10.66	20	LS-2	300
16	150B	10	21 1/4	21	23 1/2	22 9/16	1 7/16	1 3/8	14 5/8	16 3/4	3 1/2	20 1/8	12 1/16	3 1/2	4	14.81	35	LS-3	600

* MINIMUM PIPE I.D. TO CLEAR BUTTERFLY VALVE DISC (CHAMFER PIPE I.D. AT 45°) IF NECESSARY.

150B FLANGE X MECHANICAL JOINT BUTTERFLY VALVE WITH BURIED SERVICE ACTUATOR

DATE 7-1-04

VAL-MATIC® VALVE AND MANUFACTURING CORP.

DRWG. NO.
VM-2606/BLSA